

harman/kardon

AVR320

A/V DOLBY DIGITAL RECEIVER

SERVICE MANUAL



CONTENTS

ESD WARNING.....	2	BULLETIN H/K2002-07.....	20
LEAKAGE TESTING.....	3	BULLETIN H/K2003-07.....	21
BASIC SPECIFICATIONS.....	4	TECH TIP HKTT2003-01.....	23
FRONT PANEL CONTROLS.....	5	TECH TIP HKTT2004-03.....	24
REAR PANEL CONNECTIONS.....	10	IDLE CURRENT ADJUSTMENT.....	28
REMOTE CONTROL FUNCTIONS.....	12	BLOCK DIAGRAM.....	31
TROUBLESHOOTING GUIDE.....	15	ELECTRICAL PARTS LIST.....	32
PROCESSOR RESET.....	15	SEMICONDUCTOR PINOUTS.....	77
UNIT EXPLODED VIEW.....	16	SCHEMATICS.....	136
EXPLODED VIEW PARTS LIST.....	17	WIRING DIAGRAM.....	157
BULLETIN H/K2002-03.....	19	PACKAGE.....	158

harman/kardon, Inc.
 250 Crossways Park Dr.
 Woodbury, New York 11797

Rev5 – 6/2005

ELECTROSTATICALLY SENSITIVE (ES) DEVICES

Some semiconductor (solid state) devices can be damaged easily by static electricity. Such components commonly are called Electrostatically Sensitive (ES) Devices. Examples of typical ES devices are integrated circuits and some field effect transistors and semiconductor "chip" components.

The following techniques should be used to help reduce the incidence of component damage caused by static electricity.



1. Immediately before handling any semiconductor component or semiconductor-equipped assembly, drain off any electrostatic charge on your body by touching a known earth ground. Alternatively, obtain and wear a commercially available discharging wrist strap device, which should be removed for potential shock reasons prior to applying power to the unit under test.
2. After removing an electrical assembly equipped with ES devices, place the assembly on a conductive surface such as aluminum foil, to prevent electrostatic charge build-up or exposure of the assembly.
3. Use only a grounded-tip soldering iron to solder or unsolder ES devices.
4. Use only an anti-static solder removal device. Some solder removal devices not classified as "anti-static" can generate electrical charges sufficient to damage ES devices.
5. Do not use freon-propelled chemicals. These can generate electrical charge sufficient to damage ES devices.
6. Do not remove a replacement ES device from its protective package until immediately before you are ready to install it. (Most replacement ES devices are packaged with leads electrically shorted together by conductive foam, aluminum foil or comparable conductive material.)
7. Immediately before removing the protective material from the leads of a replacement ES device, touch the protective material to the chassis or circuit assembly into which the device will be installed.

CAUTION : Be sure no power is applied to the chassis or circuit, and observe all other safety precautions.

8. Minimize bodily motions when handling unpackaged replacement ES devices. (Otherwise harmless motion such as the brushing together of your clothes fabric or the lifting of your foot from a carpeted floor can generate static electricity sufficient to damage an ES devices.

PRODUCT SAFETY NOTICE

Each precaution in this manual should be followed during servicing.

Components identified with the IEC symbol  in the parts list are of special significance to safety. When replacing a component identified with , use only the replacement parts designated, or parts with the same ratings or resistance, wattage, or voltage that are designated in the parts list in this manual. Leakage-current or resistance measurements must be made to determine that exposed parts are acceptably insulated from the supply circuit before returning the product to the customer.

LEAKAGE TEST(FOR SERVICE ENGINEERS IN THE U.S.A)

Before returning the unit to the user, perform the following safety checks :

1. Inspect all lead dress to make certain that leads are not pinched or that hardware is not lodged between the chassis and other metal parts in the unit.
2. Be sure that any protective devices such as nonmetallic control knobs, insulating fish-papers, cabinet backs, adjustment and compartment covers or shields, isolation resistor-capacity networks, mechanical insulators, etc. Which were removed for the servicing are properly re-installed.
3. Be sure that no shock hazard exists ; check for leakage current using Simpson Model 229 Leakage Tester, standard equipment item No. 21641, RCA Model WT540A or use alternate method as follows : Plug the power cord directly into a 120 volt AC receptacle (do not use an Isolation Transformer for this test). Using two clip leads, connect a 1500 ohms, 10watt Resistor paralleled by a 0.15uF capacitor, in series with all exposed metal cabinet parts and a known earth ground, such as a water pipe or conduit. Use a VTVM or VOM with 1000 ohms per volt, or higher sensitivity to measure the AC voltage drop across the resistor. (See diagram) Move the resistor connection to each exposed metal part having a return path to the chassis (antenna, metal, cabinet, screw heads, knobs and control shafts, escutcheon, etc.) and measure the AC voltage drop across the resistor. (This test should be performed with the 0.35 volt RMS or more is excessive and indicates a potential shock hazard which must be corrected before returning the unit to the owner.

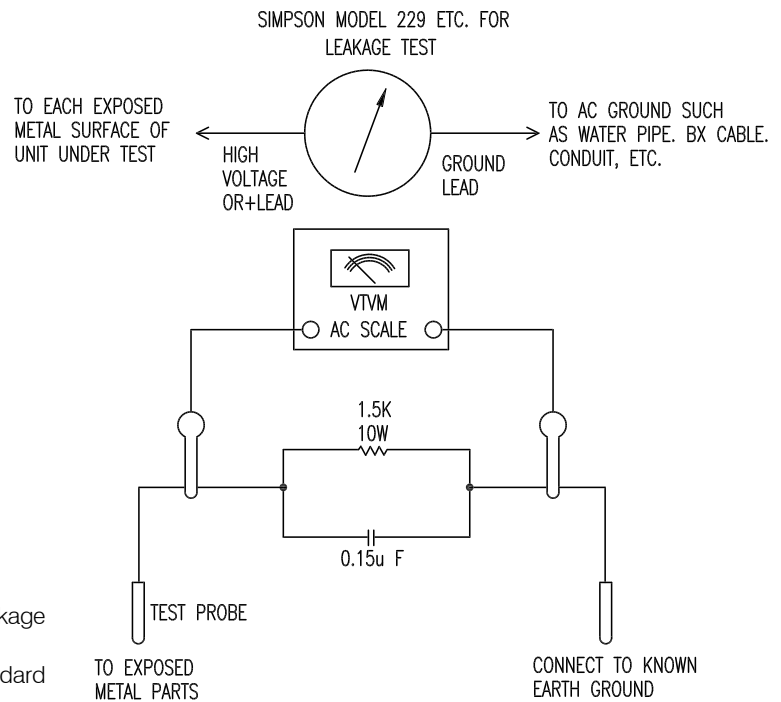

Technical Specifications

Audio Section

Stereo Mode

Continuous Average Power (FTC)

65 Watts per channel, 20Hz–20kHz,
@ < 0.07% THD, both channels driven into 8 ohms

Five-Channel Surround Modes

Power Per Individual Channel

Front L&R channels:
55 Watts per channel
@ < 0.07% THD, 20Hz–20kHz into 8 ohms

Center channel:
55 Watts @ < 0.07% THD, 20Hz–20kHz into 8 ohms

Surround channels:
55 Watts per channel
@ < 0.07% THD, 20Hz–20kHz into 8 ohms

Input Sensitivity/Impedance

Linear (High-Level) 200mV/47k ohms

Signal-to-Noise Ratio (IHF-A) 95dB

Surround System Adjacent Channel Separation

Analog Decoding 40dB
(Pro Logic II, etc.)

Dolby Digital 55dB

DTS 55dB

Frequency Response

@ 1W (+0dB, –3dB) 10Hz – 100kHz

High Instantaneous

Current Capability (HCC) ±35 Amps

Transient Intermodulation

Distortion (TIM) Unmeasurable

Slew Rate

40V/μsec

FM Tuner Section

Frequency Range 87.5–108MHz

Usable Sensitivity IHF 1.3 μV/13.2dBf

Signal-to-Noise Ratio Mono/Stereo 70/68dB

Distortion Mono/Stereo 0.2/0.3%

Stereo Separation 40dB @ 1kHz

Selectivity ±400kHz, 70dB

Image Rejection 80dB

IF Rejection 90dB

AM Tuner Section

Frequency Range 320–1720 kHz

Signal-to-Noise Ratio 45 dB

Usable Sensitivity Loop 500 μV

Distortion 1kHz, 50% Mod 0.8%

Selectivity ±10kHz, 30dB

Video Section

Television Format NTSC

Input Level/Impedance 1Vp-p/75 ohms

Output Level/Impedance 1Vp-p/75 ohms

Video Frequency Response
(Composite and S) 10Hz–8MHz (–3dB)

Video Frequency Response
(Component) 10Hz–30MHz (–3dB)

General

Power Requirement AC 120V/60Hz

Power Consumption 72W idle, 580W maximum
(2 channels driven)

Dimensions (Max)

Width 17.3 inches (440mm)

Height 6.5 inches (165mm)

Depth 17.1 inches (435mm)

Weight

32 lb (14.5kg)

Depth measurement includes knobs, buttons and terminal connections.

Height measurement includes feet and chassis.

All features and specifications are subject to change without notice.

Harman Kardon is a registered trademark, and Power for the Digital Revolution is a trademark, of Harman Kardon, Inc.

|||EzSet™ is a trademark of Harman International Industries, Inc. (Patent No. 5,386,478).

*Manufactured under license from Dolby Laboratories.

"Dolby," "Pro Logic," "Pro Logic II" and the Double-D symbol are trademarks of Dolby Laboratories. Confidential Unpublished Works. ©1992–1999 Dolby Laboratories, Inc. All rights reserved.

DTS, DTS Surround, DTS-ES and DTS Neo:6 are trademarks of Digital Theater Systems, Inc.

UltraStereo is a trademark of UltraStereo Corp.

VMAx is a registered trademark of Harman International Industries, Inc., and is an implementation of Cooper Bauck Transaural Stereo under patent license.

Logic 7 is a registered trademark of Lexicon, Inc.

Crystal is a registered trademark of Cirrus Logic Corp.

Front Panel Controls

was in use. Each subsequent press selects the next DTS mode in the following order:

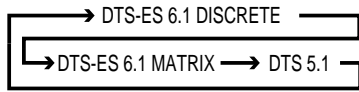

7 Logic 7 Mode Selector /◀ Button: This button has two functions: In normal use, press it to select one of the Logic 7 modes. When an adjustment is being made using the **Channel Select 26** or **Digital Select 25** buttons, this button may be pressed to scroll through the available options.

8 Tone Mode: Pressing this button enables or disables the Bass and Treble tone controls. When the button is pressed so that the words TONE IN appear in the **Main Information Display 29**, the settings of the **Bass 22** and **Treble 24** controls may be used to adjust the output signals. When the button is pressed so that the words TONE OUT appear in the **Main Information Display 29**, the output signal will be “flat,” without any bass or treble alteration, no matter how the actual **Bass and Treble Controls 22/24** are adjusted.

9 Surround Mode Selector: Press this button to change the surround mode by scrolling through the list of available modes. Note that depending on the type of input, some modes are not always available. (See page 26 for more information about surround modes.)

10 Tuning Selector: Press the left side of the button to tune lower-frequency stations and the right side of the button to tune higher-frequency stations. When a station with a strong signal is reached, the **TUNED Indicator W** will be lit in the **Main Information Display 29**.

To tune manually, tap the button lightly and note that the tuner will step up one frequency increment per button press. When the button is held for a few seconds you will note that the unit will quickly search the frequency band. Release it once the fast tuning starts; the tuner will automatically scan for the next station with an acceptable signal and then stop.

11 Tuner Band Selector: Pressing this button will automatically switch the AVR 320 to the Tuner mode. Pressing it again will switch between the AM and FM frequency bands. (See page 31 for more information on the tuner.)

12 Set Button: When making choices during the setup and configuration process, press this button to enter the desired setting as shown in the **Main Information Display 29** into the AVR 320’s memory.

13 Preset Station Selector: Press this button to scroll up or down through the list or stations that have been entered into the preset memory. (See page 32 for more information on tuner programming.)

14 Stereo Mode Selector /▶ Button: Pressing this selector button cycles through the stereo modes, and it is also used to turn off all surround processing and place the unit in a traditional two-channel Stereo mode. The first press selects 5-Channel Stereo, the next press selects 8-Channel Stereo, and the third press selects “SURROUND OFF,” which is true Stereo. When an adjustment is being made using the **Channel Select 26** or **Digital Select 25** buttons, this button may be pressed to scroll through the available options.

15 Input Source Selector: Press this button to change the input by scrolling up or down through the list of input sources.

16 FM Mode Selector: Press this button to select Auto or Manual tuning. When the button is pressed so that the **AUTO Indicator X** lights, the tuner will search for the next station with an acceptable signal when the **Tuning Selector 10 21 E** is pressed. When the button is pressed so that the **AUTO Indicator X** is not lit, each press of the **Tuning Selector 10 21 E** will increase the frequency. (See page 31 for more information on using the tuner.)

17 DTS Neo:6 Mode Selector: Pressing this selector button cycles the AVR through the various DTS Neo:6 modes, which extract a five-channel surround field from two-channel program material. The first press selects the last DTS Neo:6 surround mode that was in use, and each subsequent press selects the next mode in the following order:

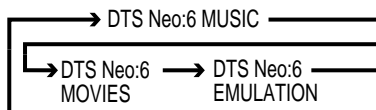

18 Digital Optical 3 Input: Connect the optical digital output of an audio or video product to this jack. When the input is not in use, be certain to keep the plastic cap installed to avoid dust contamination that might degrade future performance.

19 Input/Output Status Indicator: This LED indicator will normally light green to show that the front panel **Digital Coax 3 20** jack is operating as an input. When this jack is configured for use as an output, the indicator will turn red to show that the jack may be used for recording. (See page 20 for more information on configuring the front panel jacks as outputs, rather than inputs.)

20 Digital Coax 3 Jack: This jack is normally used for connection to the output of portable audio devices, video game consoles or other products that have a coax digital jack. It may also be configured as an output jack, to feed a digital signal to a CD-R, MiniDisc or other digital recording device. (See page 20 for information on configuring the Digital Coax 3 Jack as an output.)

21 Video 4 Input Jacks: These audio/video jacks may be used for temporary connection to video games or portable audio/video products such as camcorders and portable audio players.

22 Bass Control: Turn this control to modify the low-frequency output of the left/right channels by as much as ± 10 dB. Set this control to a suitable position for your taste or room acoustics.

23 Balance Control: Turn this control to change the relative volume for the front left/right channels.

NOTE: For proper operation of the surround modes, this control should be at the midpoint, or “12 o’clock”, position.

24 Treble Control: Turn this control to modify the high-frequency output of the left/right channels by as much as ± 10 dB. Set this control to a suitable position for your taste or room acoustics.

25 Digital Select Button: When playing a source that has a digital output, press this button to select between the **Optical 18 31** and **Coaxial 20 32** Digital inputs. (See page 29 for more information on digital audio.)

26 Channel Select Button: Press this button to begin the process of trimming the channel output levels using an external audio source. (For more information on output level trim adjustment, see page 32.)

27 Volume Control: Turn this knob clockwise to increase the volume, counterclockwise to decrease the volume. If the AVR 320 is muted, adjusting volume control will automatically release the unit from the silenced condition.

Front Panel Controls

28 Input Indicators: A green LED will light to the left of the input that is currently the input source for the AVR 320.

29 Main Information Display: This display delivers messages and status indications to help you operate the receiver. (See pages 8 & 9 for a complete explanation of the Information Display.)

30 Remote Sensor Window: The sensor behind this window receives infrared signals from the remote control. Aim the remote at this area and do not block or cover it unless an external remote sensor is installed.

31 Surround Mode Indicators: A green LED will light in front of the surround mode that is currently in use.

Front Panel Information Display

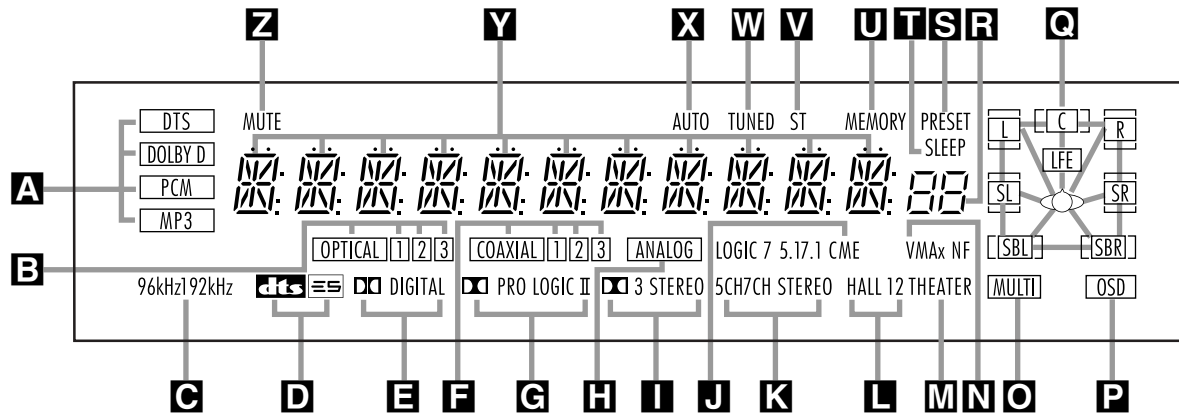

- A** Bitstream Indicators
- B** Optical Source Indicators
- C** Sample Rate Indicators
- D** DTS Mode Indicator
- E** Dolby Digital Indicator
- F** Coaxial Source Indicators
- G** Dolby Pro Logic II Indicator
- H** Analog Input Indicator
- I** Dolby 3 Stereo Indicator
- J** Logic 7 Mode Indicators
- K** 5-Channel/7-Channel Stereo Indicators
- L** Hall Mode Indicators
- M** Theater Mode Indicator
- N** VMAx Mode Indicators
- O** Multiroom Indicator
- P** OSD Indicator
- Q** Speaker/Channel Input Indicators
- R** Preset Number/Sleep Timer
- S** Preset Indicator
- T** Sleep Indicator
- U** Memory Indicator
- V** Stereo Indicator
- W** Tuned Indicator
- X** Auto Indicator
- Y** Main Information Display
- Z** Mute Indicator

A Bitstream Indicators: When the input is a digital source, one of these indicators will light to display the specific type of data signal in use.

B Optical Source Indicators: These indicators light to show when an Optical Digital Input has been selected.

C Sample Rate Indicators: One of these indicators will light when 96kHz or 192kHz source material is in use.

D DTS Mode Indicator: This indicator lights when a DTS-encoded source is playing.

E Dolby Digital Indicator: This indicator lights when a Dolby Digital source is being played.

F Coaxial Source Indicators: These indicators light to show when a Coaxial Digital Input has been selected.

G Dolby Pro Logic II Indicator: This indicator lights when the Dolby Pro Logic II mode has been selected.

NOTE: It is possible to see the Dolby Pro Logic II indicator lit simultaneously with the Dolby Digital indicator, even though the Dolby Digital surround mode has been selected. This is due to the specifications for Dolby Digital processing, which require that the Dolby Pro Logic II mode be applied when a 2-channel Dolby signal is detected. If you desire 5.1-channel audio, check the audio settings in the menus for your DVD disc to make sure that a 5.1-channel Dolby

Digital soundtrack has been selected.

H Analog Input Indicator: This indicator lights when an analog input source has been selected.

I Dolby 3 Stereo Indicator: This indicator lights when the Dolby 3 Stereo mode has been selected.

J Logic 7 Mode Indicators: These indicators light to indicate that one of the Logic 7 modes is in use. Along with the main Logic 7 indicator, either 5.1 or 7.1 will light to indicate the selected speaker configuration. One of the three letters to the far right of this segment will light to show which version of Logic 7 processing is in use: C for the Cinema mode, M for the Music mode and E for the Enhanced mode used with two-channel sources. The Enhanced mode is only available with the 5.1 speaker configuration. (See page 26 for a description of the Logic 7 modes.)

K 5-Channel/7-Channel Stereo Indicators: These indicators light to show if the 5-Channel or 7-Channel Stereo mode has been selected.

L Hall Mode Indicators: These indicators light when one of the Hall modes has been selected.

M Theater Mode Indicator: This indicator lights to show that the Theater mode is in use.

N VMAx Mode Indicators: One of these indicators lights when the VMAx mode is in use. **VMAx F** appears when the Far Field VMAx mode is selected; **VMAx N** appears when the Near Field VMAx mode is selected. (See page 27 for a description of the VMAx modes.)

O Multiroom Indicator: This indicator lights when the multiroom system is active. Note that it will remain lit when the multiroom system is in use even though the main room system is in the Standby mode and all other indicators are dark. (See page 36 for more information on the Multiroom system.)

P OSD Indicator: When the OSD system is in use, this indicator lights to remind you that the other indicators in this display do not function when the On-Screen Display is being used.

Q Speaker/Channel Input Indicators: These indicators are multipurpose, indicating either the speaker type selected for each channel or the incoming data-signal configuration. The left, center, right, right surround and left surround speaker indicators are composed of three boxes, while the subwoofer is a single box. The center box lights when a "Small" speaker is selected, and the two outer boxes light when "Large" speakers are selected. When none of the boxes are lit for the center, surround or subwoofer channels, no speaker has been selected for one of those positions. (See page 22 for more infor-

Front Panel Information Display

mation on configuring speakers.) The letters inside each of the center boxes display the active input channels. For standard analog inputs, only the L and R will light, indicating a stereo input. When a digital source is playing, the indicators will light to display the channels being received at the digital input. When the letters flash, the digital input has been interrupted. (See pages 23 & 30 for more information on the Channel Indicators.)

R Preset Number/Sleep Timer: When the tuner is in use, these numbers indicate the specific preset memory location in use. (See page 32 for more information on preset stations.) When the Sleep function is in use, these numbers show how many minutes remain before the unit goes into the Standby mode.

S Preset Indicator: This indicator lights when the tuner is in use to show that the **Preset Number/Sleep Timer R** is showing the station's preset memory number. (See page 32 for more information on tuner presets.)

T Sleep Indicator: This indicator lights when the Sleep function is in use. The numbers in the **Preset Number/Sleep Timer R** indicator will show the minutes remaining before the AVR 320 goes into the Standby mode. (See page 28 for more information on the Sleep function.)

U Memory Indicator: This indicator flashes when entering presets and other information into the tuner's memory.

V Stereo Indicator: This indicator lights when an FM station is being tuned in stereo.

W Tuned Indicator: This indicator lights when a station is being received with sufficient signal strength to provide acceptable listening quality.

X Auto Indicator: This indicator lights when the tuner's Auto mode is in use.

Y Main Information Display: This display shows messages relating to the status, input source, surround mode, tuner, volume level or other aspects of the AVR 320's operation.

Z Mute Indicator: This indicator lights to remind you that the AVR 320's output has been silenced by pressing the **Mute Button**  **43**. Press the Mute button again to return to the previously selected output level.

Rear Panel Connections

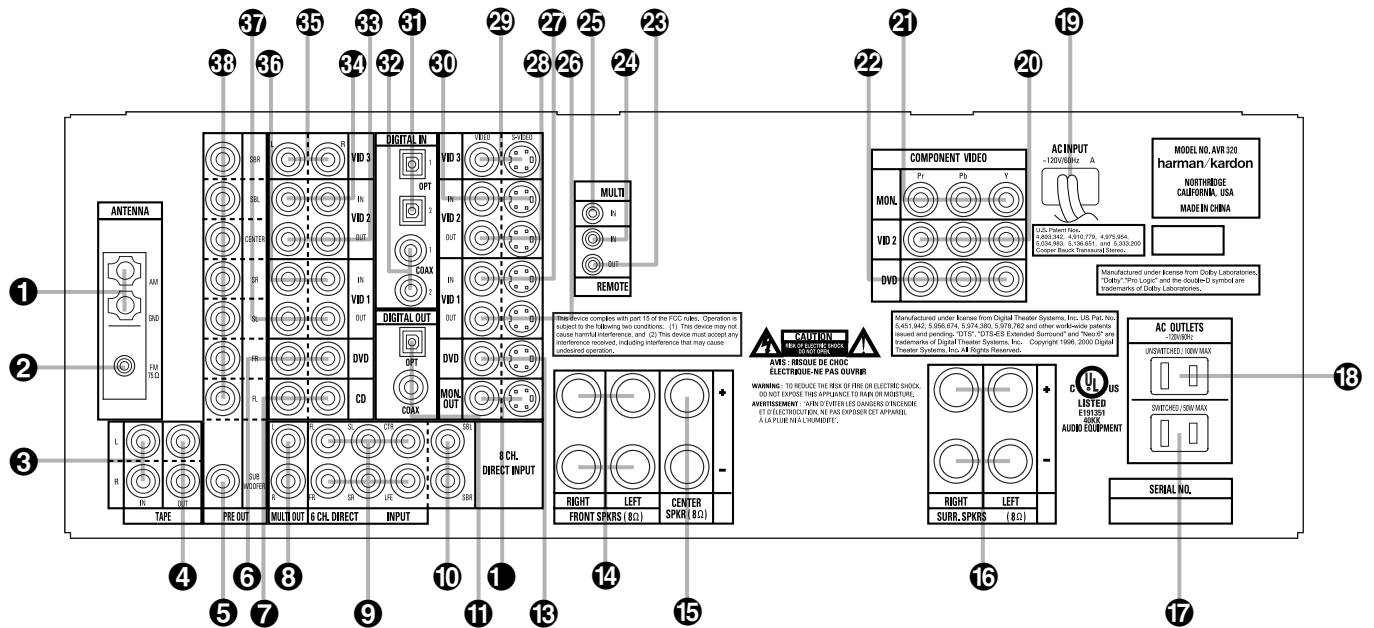

- 1 AM Antenna
- 2 FM Antenna
- 3 Tape Inputs
- 4 Tape Outputs
- 5 Subwoofer Output
- 6 DVD Audio Inputs
- 7 CD Inputs
- 8 Multiroom Outputs
- 9 6-Channel Direct Inputs
- 10 8-Channel Direct Inputs
- 11 Digital Audio Outputs
- 12 Video Monitor Outputs
- 13 DVD Video Inputs

- 14 Front Speaker Outputs
- 15 Center Speaker Outputs
- 16 Surround Speaker Outputs
- 17 Switched AC Accessory Outlet
- 18 Unswitched AC Accessory Outlet
- 19 AC Power Cord
- 20 Video 2 Component Video Inputs
- 21 Component Video Outputs
- 22 DVD Component Video Inputs
- 23 Remote IR Output
- 24 Remote IR Input
- 25 Multiroom IR Input
- 26 Video 1 Video Outputs

- 27 Video 1 Video Inputs
- 28 Video 2 Video Outputs
- 29 Video 3 Video Inputs
- 30 Video 2 Video Inputs
- 31 Optical Digital Inputs
- 32 Coaxial Digital Inputs
- 33 Video 2 Audio Outputs
- 34 Video 2 Audio Inputs
- 35 Video 3 Audio Inputs
- 36 Video 1 Audio Inputs
- 37 Video 1 Audio Outputs
- 38 Preamp Outputs

1 AM Antenna: Connect the AM loop antenna supplied with the receiver to these terminals. If an external AM antenna is used, make connections to the **AM** and **GND** terminals in accordance with the instructions supplied with the antenna.

2 FM Antenna: Connect the supplied indoor or an optional external FM antenna to this terminal.

3 Tape Inputs: Connect these jacks to the **PLAY/OUT** jacks of an audio recorder.

4 Tape Outputs: Connect these jacks to the **RECORD/INPUT** jacks of an audio recorder.

5 Subwoofer Output: Connect this jack to the line-level input of a powered subwoofer. If an external subwoofer amplifier is used, connect this jack to the subwoofer amplifier input.

6 DVD Audio Inputs: Connect these jacks to the analog audio jacks on a DVD or other video source.

7 CD Inputs: Connect these jacks to the output of a compact disc player or CD changer.

8 Multiroom Outputs: Connect these jacks to an optional audio power amplifier to listen to the source selected by the multiroom system in a remote room.

9 6-Channel Direct Inputs: When an optional, external processor or playback device with 5.1 audio capability is in use, connect the player's output jacks here.

NOTE: To assist in making the correct connections for multichannel input output and speaker connections, all connection jacks and terminals have been color coded in conformance with the latest CEA standards as follows:

- Front Left: White
- Front Right: Red
- Center: Green
- Surround Left: Blue

- Surround Right: Gray
- Surround Back Left: Brown
- Surround Back Right: Tan
- Subwoofer: Purple
- Digital Audio: Orange
- Composite Video: Yellow
- Component Video "Y": Green
- Component Video "Pr": Red
- Component Video "Pb": Blue

10 8-Channel Direct Inputs: When an optional, external processor or playback device with 6.1 or 7.1 audio capability is in use, connect the Surround Back Left and Surround Back Right channel outputs of the player to these input jacks.

11 Digital Audio Outputs: Connect these jacks to the matching digital input connector on a digital recorder such as a CD-R or MiniDisc recorder.

Rear Panel Connections

11 Video Monitor Outputs: Connect this jack to the composite or S-Video input of a TV monitor or video projector to view the on-screen menus and the output of any standard video source selected by the receiver's video switcher.

13 DVD Video Inputs: Connect these jacks to the composite or S-Video output jacks on a DVD or other video source.

14 Front Speaker Outputs: Connect these outputs to the matching + or – terminals on your left and right speakers. When making speaker connections always make certain to maintain correct polarity by connecting the red (+) terminals on the AVR 320 to the red (+) terminals on the speakers and the black (–) terminals on the AVR 320 to the black (–) terminals on the speakers. See page 16 for more information on speaker polarity.

15 Center Speaker Outputs: Connect these outputs to the matching + and – terminals on your center channel speaker. In conformance with the new CEA color code specification, the Green Terminal is the positive, or "+" terminal that should be connected to the red (+) terminal on speakers with the older color coding. Connect the black (–) terminal on the AVR to the black negative (–) terminal on your speaker. (See page 16 for more information on speaker polarity.)

16 Surround Speaker Outputs: Connect these outputs to the matching + and – terminals on your surround channel speakers. In conformance with the new CEA color code specification, the Blue terminal is the positive, or "+" terminal that should be connected to the red (+) terminal on the Surround Left speaker with older color coding, while the Gray terminal should be connected to the red (+) terminal on the Surround Right speaker with the older color coding. Connect the black (–) terminal on the AVR to the matching black negative (–) terminals for each surround speaker. (See page 17 for more information on speaker polarity.)

17 Switched AC Accessory Outlet: This outlet may be used to power any device you wish to have turned on when the AVR 320 is turned on with the **System Power Control Button** **2**.

18 Unswitched AC Accessory Outlet: This outlet may be used to power any AC device. The power will remain on at this outlet regardless of whether the AVR 320 is on or off.

NOTE: The total power consumption of all devices connected to the accessory outlets should not exceed 100 watts.

19 AC Power Cord: Connect the AC plug to an unswitched AC wall output.

20 Video 2 Component Video Inputs: Connect the Y/Pr/Pb component video outputs of an HDTV Set-top converter, satellite receiver, or other video source device with component video outputs to these jacks.

21 Component Video Outputs: Connect these outputs to the component video inputs of a video projector or monitor. When a source connected to one of the two **Component Video Inputs** **20/22** is selected the signal will be sent to these jacks.

22 DVD Component Video Inputs: Connect the Y/Pr/Pb component video outputs of a DVD player to these jacks.

23 Remote IR Output: This connection permits the IR sensor in the receiver to serve other remote controlled devices. Connect this jack to the "IR IN" jack on Harman Kardon (or other compatible) equipment.

24 Remote IR Input: If the AVR 320's front-panel IR sensor is blocked due to cabinet doors or other obstructions, an external IR sensor may be used. Connect the output of the sensor to this jack.

25 Multiroom IR Input: Connect the output of an IR sensor in a remote room to this jack to operate the AVR 320's multiroom control system.

26 Video 1 Video Outputs: Connect these jacks to the **RECORD/INPUT** composite or S-Video jack on a VCR.

27 Video 1 Video Inputs: Connect these jacks to the **PLAY/OUT** composite or S-Video jacks on a VCR or other video source.

28 Video 2 Video Outputs: Connect these jacks to the **RECORD/INPUT** composite or S-Video jacks on a VCR.

29 Video 3 Video Inputs: Connect these jacks to the **PLAY/OUT** composite or S-Video jacks on a VCR or other video source.

30 Video 2 Video Inputs: Connect these jacks to the **PLAY/OUT** composite or S-Video jacks on a VCR or other video source.

31 Optical Digital Inputs: Connect the optical digital output from a DVD player, HDTV receiver, the S/P-DIF output of a compatible computer sound card playing MP3 files or streams, LD player or CD player to these jacks. The signal may be either a Dolby Digital signal, a DTS signal or a standard PCM digital source.

32 Coaxial Digital Inputs: Connect the coaxial digital output from a DVD player, HDTV receiver, the S/P-DIF output of a compatible computer sound card playing MP3 files or streams, LD player or CD player to these jacks. The signal may be either a Dolby Digital signal, DTS signal or a standard PCM digital source. Do not connect the RF digital output of an LD player to these jacks.

33 Video 2 Audio Outputs: Connect these jacks to the **RECORD/INPUT** audio jacks on a VCR or other video source.

34 Video 2 Audio Inputs: Connect these jacks to the **PLAY/OUT** audio jacks on a VCR or other video source.

35 Video 3 Audio Inputs: Connect these jacks to the **PLAY/OUT** audio jacks on a VCR or other video source.

36 Video 1 Audio Inputs: Connect these jacks to the **PLAY/OUT** audio jacks on a VCR or other video source.

37 Video 1 Audio Outputs: Connect these jacks to the **RECORD/INPUT** audio jacks on a VCR.

38 Preamp Outputs: These jacks may be connected to the inputs of an optional, external power amplifier.

Main Remote Control Functions

- 1 Power Off Button
- 2 IR Transmitter Window
- 3 Program/SPL Indicator
- 4 Power On Button
- 5 Input Selectors
- 6 AVR Selector
- 7 AM/FM Tuner Select
- 8 6-Channel/8-Channel Direct Input
- 9 Test Button
- 10 Sleep Button
- 11 Surround Mode Selector
- 12 Night Mode
- 13 Channel Select Button
- 14 ▲/▼ Buttons
- 15 ◀ Button
- 16 Set Button
- 17 Digital Select
- 18 Numeric Keys
- 19 Tuner Mode
- 20 Direct Button
- 21 Tuning Up/Down
- 22 OSD Button
- 23 Dolby Mode Select Button
- 24 DTS Digital Mode Selector
- 25 Logic 7 Mode Select Button
- 26 Skip Down Button
- 27 Transport Controls
- 28 Skip Up Button
- 29 Stereo Mode Select Button
- 30 DTS Neo:6 Mode Select
- 31 Macro Buttons
- 32 Disc Skip Button
- 33 Preset Up/Down
- 34 Clear Button
- 35 Memory Button
- 36 Delay/Prev. Ch.
- 37 ▶ Button
- 38 Speaker Select
- 39 Multiroom
- 40 Volume Up/Down
- 41 SPL Indicator Select
- 42 Learn Button
- 43 Mute
- 44 EzSet Sensor Microphone

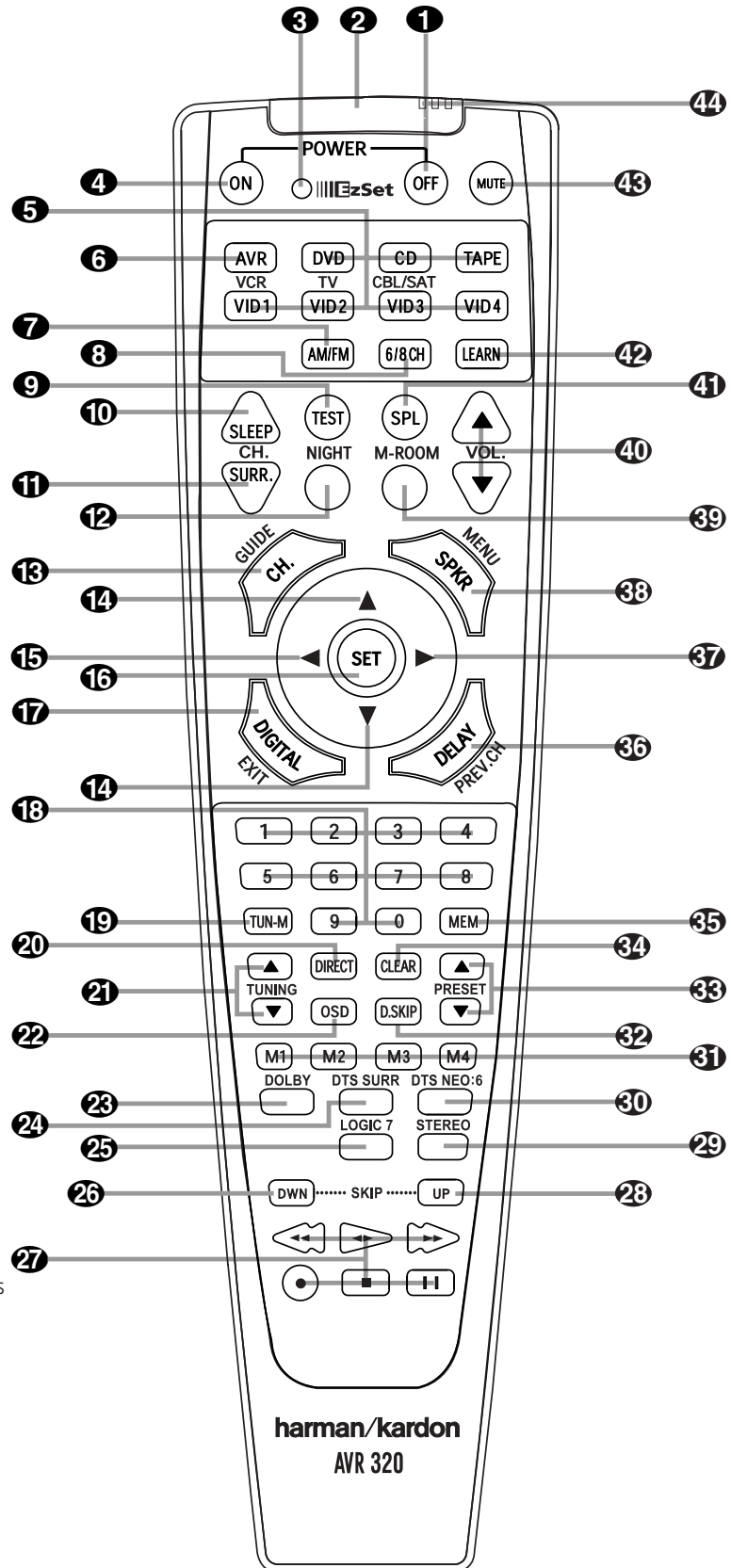

NOTE: The function names shown here are each button's feature when used with the AVR 320. Most buttons have additional functions when used with other devices. See pages 42–43 for a list of these functions.

Main Remote Control Functions

IMPORTANT NOTE: The AVR 320's remote may be programmed to control up to eight devices, including the AVR 320. Before using the remote, it is important to remember to press the **Input Selector Button 5** that corresponds to the unit you wish to operate. In addition, the AVR 320's remote is shipped from the factory to operate the AVR 320 and most Harman Kardon CD or DVD players and cassette decks. The remote is also capable of operating a wide variety of other products using the control codes that are part of the remote. Before using the remote with other products, follow the instructions on pages 37–41 to program the proper codes for the products in your system.

It is also important to remember that many of the buttons on the remote take on different functions, depending on the product selected using the Device Control Selectors. The descriptions shown here primarily detail the functions of the remote when it is used to operate the AVR 320. (See page 39 for information about alternate functions for the remote's buttons.)

1 Power Off Button: Press this button to place the AVR 320 or a selected device in the Standby mode. Note that this will turn off the main room functions, but if the Multiroom system is activated, it will continue to function.

2 IR Transmitter Window: Point this window towards the AVR 320 when pressing buttons on the remote to make certain that infrared commands are properly received.

3 Program/SPL Indicator: This three-color indicator is used to guide you through the process of programming the remote or learning commands from a remote into the AVR 320's remote code memory and it is also used as a level indicator when using the remote's EzSet capabilities. (See page 24 for more information on setting output levels, and see page 37 for information on programming the remote.)

4 Power On Button: Press this button to turn on the power to a device selected by pressing one of the **Input Selectors 5**.

5 Input Selectors: Pressing one of these buttons will perform three actions at the same time. First, if the AVR 320 is not turned on, this will power up the unit. Next, it will select the source shown on the button as the input to the AVR 320. Finally, it will change the remote control so that it controls the device selected. After pressing one of these buttons you must press the **AVR Selector Button 6** again to operate the AVR 320's functions with the remote.

6 AVR Selector: Pressing this button will switch the remote so that it will operate the

AVR 320's functions. If the AVR 320 is in the Standby mode, it will also turn the AVR 320 on.

7 AM/FM Tuner Select: Press this button to select the AVR 320's tuner as the listening choice. Pressing this button when the tuner is already in use will select between the AM and FM bands.

8 6-Channel/8-Channel Direct Input: Press this button to select the device connected to the **6-Channel Direct Inputs 9** or the **8-Channel Direct Inputs 10**. (See page 33 for more information.)

9 Test Button: Press this button to begin the sequence used to calibrate the AVR 320's output levels. (See page 24 for more information on calibrating the AVR 320.)

10 Sleep Button: Press this button to place the unit in the Sleep mode. After the time shown in the display, the AVR 320 will automatically go into the Standby mode. Each press of the button changes the time until turn-off in the following order:

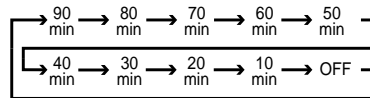

Note that this button is also used to change channels on your TV when the TV is selected.

When the AVR 320 remote is being programmed with the codes to operate another device, this button is also used in the "Auto Search" process. (See page 37 for more information on programming the remote.)

11 Surround Mode Selector: Press this button to begin the process of changing the surround mode. After the button has been pressed, use the **▲/▼ Buttons 14** to select the desired surround mode. (See page 28 for more information.) Note that this button is also used to tune channels when the TV is selected using the device **Input Selector 5**. When the AVR 320 remote is being programmed with the codes of another device, this button is also used in the "Auto Search" process. (See page 37 for more information on programming the remote.)

12 Night Mode: Press this button to activate the Night mode. This mode is available in specially encoded digital sources, and it preserves dialog (center channel) intelligibility at low volume levels.

13 Channel Select Button: This button is used to start the process of setting the AVR 320's output levels to an external source. Once this but-

ton is pressed, use the **▲/▼ Buttons 14** to select the channel being adjusted, then press the **Set Button 16**, followed by the **▲/▼ Buttons 14** again, to change the level setting. (See page 32 for more information.)

14 ▲/▼ Buttons: These multipurpose buttons are used to change or scroll through items in the on-screen menus, make configuration settings such as digital inputs or delay timing, or to select surround modes. When changing a setting, first press the button for the function or setting to be changed (e.g., press the **Surround Mode Selector 11** to select a soundfield mode or the **Digital Select Button 17** to change a digital input) and then press one of these buttons to scroll through the list of options or to increase or decrease a setting. The sections in this manual describing the individual features and functions contain specific information on using these buttons for each application.

15 ◀ Button: This button is used to change the menu selection or setting during some of the setup procedures for the AVR 320.

16 Set Button: This button is used to enter settings into the AVR 320's memory. It is also used in the setup procedures for delay time, speaker configuration and channel output level adjustment.

17 Digital Select: Press this button to assign one of the digital inputs **31 32 18 20** to a source. (See page 29 for more information on using digital inputs.)

18 Numeric Keys: These buttons serve as a ten-button numeric keypad to enter tuner preset positions. They are also used to select channel numbers when TV, Cable or SAT has been selected on the remote, or to select track numbers on a CD, DVD or LD player, depending on how the remote has been programmed.

19 Tuner Mode: Press this button when the tuner is in use to select between automatic tuning and manual tuning. When the button is pressed so that the **AUTO Indicator X** goes out, pressing the **Tuning Buttons 21 10 E** will move the frequency up or down in single-step increments. When the FM band is in use, pressing this button when a station's signal is weak will change to monaural reception. (See page 31 for more information.)

20 Direct Button: Press this button when the tuner is in use to start the sequence for direct entry of a station's frequency. After pressing the button, simply press the proper **Numeric Keys 18** to select a station. (See page 32 for more information on the tuner.)

Main Remote Control Functions

21 Tuning Up/Down: When the tuner is in use, these buttons will tune up or down through the selected frequency band. If the **Tuner Mode Button 19 16** has been pressed so that the **AUTO Indicator X** is illuminated, pressing and holding either of the buttons for three seconds will cause the tuner to seek the next station with acceptable signal strength for quality reception. When the **AUTO Indicator X** is NOT illuminated, pressing these buttons will tune stations in single-step increments. (See page 31 for more information.)

22 OSD Button: Press this button to activate the On-Screen Display (OSD) system used to set up or adjust the AVR 320's parameters.

23 Dolby Mode Selector: This button is used to select from among the available Dolby Surround processing modes. Each press of this button will select one of the Dolby Pro Logic II modes or Dolby 3 Stereo. When a Dolby Digital encoded source is in use, the Dolby Digital mode may also be selected. (See page 26 for the available Dolby surround mode options.)

24 DTS Digital Mode Selector: When a DTS-encoded digital source is selected, each press of this button will scroll through the available DTS modes. The specific choice of modes will vary according to whether or not the source material contains DTS-ES 6.1 Discrete encoding. When a DTS source is not in use, this button has no function. (See page 40 for the available DTS Digital options.)

25 Logic 7 Selector: Press this button to select from among the available Logic 7 surround modes. (See page 26 for the available Logic 7 options.)

26 Skip Down Button: This button does not have a direct function on the AVR 320, but when used with a compatibly programmed CD or DVD changer it will change to the previous disc in the changer or carousel.

27 Transport Controls: These buttons do not have any functions for the AVR 320, but they may be programmed for the forward/reverse play operation of a wide variety of CD or DVD players, and audio or video cassette recorders. (See page 40 for more information.)

28 Skip Up Button: This button does not have a direct function on the AVR 320, but when used with a compatibly programmed CD or DVD changer it will change to the previous disc in the changer or carousel.

29 Stereo Mode Select Button: Pressing this button cycles through the stereo modes, and it is also used to turn off all surround

processing and place the unit in a traditional two-channel Stereo mode. The first press selects 5-Channel Stereo, the next press selects 8-Channel Stereo, and the third press selects "SURROUND OFF," which is true Stereo.

30 Macro Buttons: Press these buttons to store or recall a "Macro", which is a preprogrammed sequence of commands stored in the remote. (See page 38 for more information on storing and recalling macros.)

31 DTS Neo:6 Mode Select: Pressing this button cycles the AVR through the various DTS Neo:6 modes, which extract a five-channel surround field from two-channel program material. The first press selects the last DTS Neo:6 surround mode that was in use, and each subsequent press selects one of the other DTS Neo:6 modes.

32 Disc Skip Button: This button has no direct function for the AVR 320 but is most often used to change to the next disc in a CD or DVD player when the remote is programmed for that type of device. (See page 37 for more information on using the remote with products other than the AVR 320.)

33 Preset Up/Down: When the tuner is in use, press these buttons to scroll through the stations programmed into the AVR 320's memory. When some source devices, such as CD players, VCRs and cassette decks, are selected using the device **Input Selectors 5**, these buttons may function as Chapter Step or Track Advance.

34 Clear Button: Press this button to clear incorrect entries when using the remote to directly enter a radio station's frequency.

35 Memory Button: Press this button to enter a radio station into the AVR 320's preset memory. Once the **MEMORY Indicator U** flashes, you have five seconds to enter a preset memory location using the **Numeric Keys 18**. (See page 31 for more information.)

36 Delay/Prev Ch.: Press this button to begin the process for setting the delay times used by the AVR 320 when processing surround sound. After pressing this button, the delay times are entered by pressing the **Set Button 16** and then using the **▲/▼ Buttons 14** to change the setting. Press the **Set Button 16** again to complete the process. (See page 23 for more information.)

37 ► Button: Press this button to change a setting or selection when configuring many of the AVR 320's settings.

38 Speaker Select: Press this button to begin the process of configuring the AVR 320's bass management system for use with the type of speakers used in your system. Once the button has been pressed, use the **▲/▼ Buttons 14** to select the channel you wish to set up. Press the **Set Button 16** and then select another channel to configure. When all adjustments have been completed, press the **Set Button 16** twice to exit the settings and return to normal operation. (See page 22 for more information.)

39 Multiroom: Press this button to activate the multiroom system or to begin the process of changing the input or volume level for the second zone. (See page 36 for more information on the Multiroom system.)

40 Volume Up/Down: Press these buttons to raise or lower the system volume.

41 SPL Indicator Select: This button activates the AVR 320's EzSet function to quickly and accurately calibrate the AVR 320's output levels. Press and hold the button for three seconds and then release it. Note that the test tone will begin circulating, and the **Program/SPL Indicator 3** will change colors. During this sequence, EzSet will automatically adjust the output levels for all channels until they are equal, as shown by the **Program/SPL Indicator 3** lighting green for each channel. Press this button again when the adjustment is complete to turn off the test tone. (See page 24 for more information on EzSet.)

42 Learn Button: Press this button to begin the process of "learning" the codes from another product's remote into the AVR 320's remote. (See page 37 for more information on using the remote's learning function.)

43 Mute: Press this button to momentarily silence the AVR 320 or TV set being controlled, depending on which device has been selected. When the AVR 320 remote is being programmed to operate another device, this button is pressed with the **Input Selector Button 5** to begin the programming process. (See page 37 for more information on programming the remote.)

44 EzSet Sensor Microphone: The sensor microphone for the EzSet microphone is behind these slots. When using the remote to calibrate speaker output levels using EzSet, be sure that you do not hold the remote in a way that covers these slots. (See page 24 for more information on using EzSet.)

Troubleshooting Guide

SYMPTOM	CAUSE	SOLUTION
Unit does not function when Main Power Switch is pushed	<ul style="list-style-type: none"> No AC Power 	<ul style="list-style-type: none"> Make certain AC power cord is plugged into a live outlet Check to see whether outlet is switch-controlled
Display lights, but no sound or picture	<ul style="list-style-type: none"> Intermittent input connections Mute is on Volume control is down 	<ul style="list-style-type: none"> Make certain that all input and speaker connections are secure Press Mute button Turn up volume control
Unit turns on, but front panel display does not light up	<ul style="list-style-type: none"> Display brightness is turned off 	<ul style="list-style-type: none"> Follow the instructions in the Display Brightness section on page 35 so that the display is set to VFD FULL
No sound from any speaker; light around power switch is red	<ul style="list-style-type: none"> Amplifier is in protection mode due to possible short Amplifier is in protection mode due to internal problems 	<ul style="list-style-type: none"> Check speaker wire connections for shorts at receiver and speaker ends Contact your local Harman Kardon service depot
No sound from surround or center speakers	<ul style="list-style-type: none"> Incorrect surround mode Input is monaural Incorrect configuration Stereo or Mono program material 	<ul style="list-style-type: none"> Select a mode other than Stereo There is no surround information from mono sources Check speaker mode configuration The surround decoder may not create center- or rear-channel information from nonencoded programs
Unit does not respond to remote commands	<ul style="list-style-type: none"> Weak batteries in remote Wrong device selected Remote sensor is obscured 	<ul style="list-style-type: none"> Change remote batteries Press the AVR selector Make certain front panel sensor is visible to remote or connect remote sensor
Intermittent buzzing in tuner	<ul style="list-style-type: none"> Local interference 	<ul style="list-style-type: none"> Move unit or antenna away from computers, fluorescent lights, motors or other electrical appliances
Letters flash in the channel indicator display and digital audio stops	<ul style="list-style-type: none"> Digital audio feed paused 	<ul style="list-style-type: none"> Resume play for DVD Check that Digital Input is selected

Processor Reset

In the rare case where the unit's operation or the displays seem abnormal, the cause may involve the erratic operation of the system's memory or microprocessor.

To correct this problem, first unplug the unit from the AC wall outlet and wait at least three minutes. After the pause, reconnect the AC power cord and check the unit's operation. If the system still malfunctions, a system reset may clear the problem.

To clear the AVR 320's entire system memory including tuner presets, output level settings,

delay times and speaker configuration data, first put the unit in Standby by pressing the **System Power Control Button** **2**. Next, press and hold the **Tone Mode** **8** and the **FM Mode Selector** **16** buttons for three seconds.

The unit will turn on automatically and display the **RESET** message in the **Main Information Display** **Y**. Note that once you have cleared the memory in this manner, it is necessary to reestablish all system configuration settings and tuner presets.

NOTE: Resetting the processor will erase any configuration settings you have made for

speakers, output levels, surround modes, digital input assignments as well as the tuner presets. After a reset the unit will be returned to the factory presets, and all settings for these items must be reentered.

If the system is still operating incorrectly, there may have been an electronic discharge or severe AC line interference that has corrupted the memory or microprocessor.

If these steps do not solve the problem, consult an authorized Harman Kardon service center.

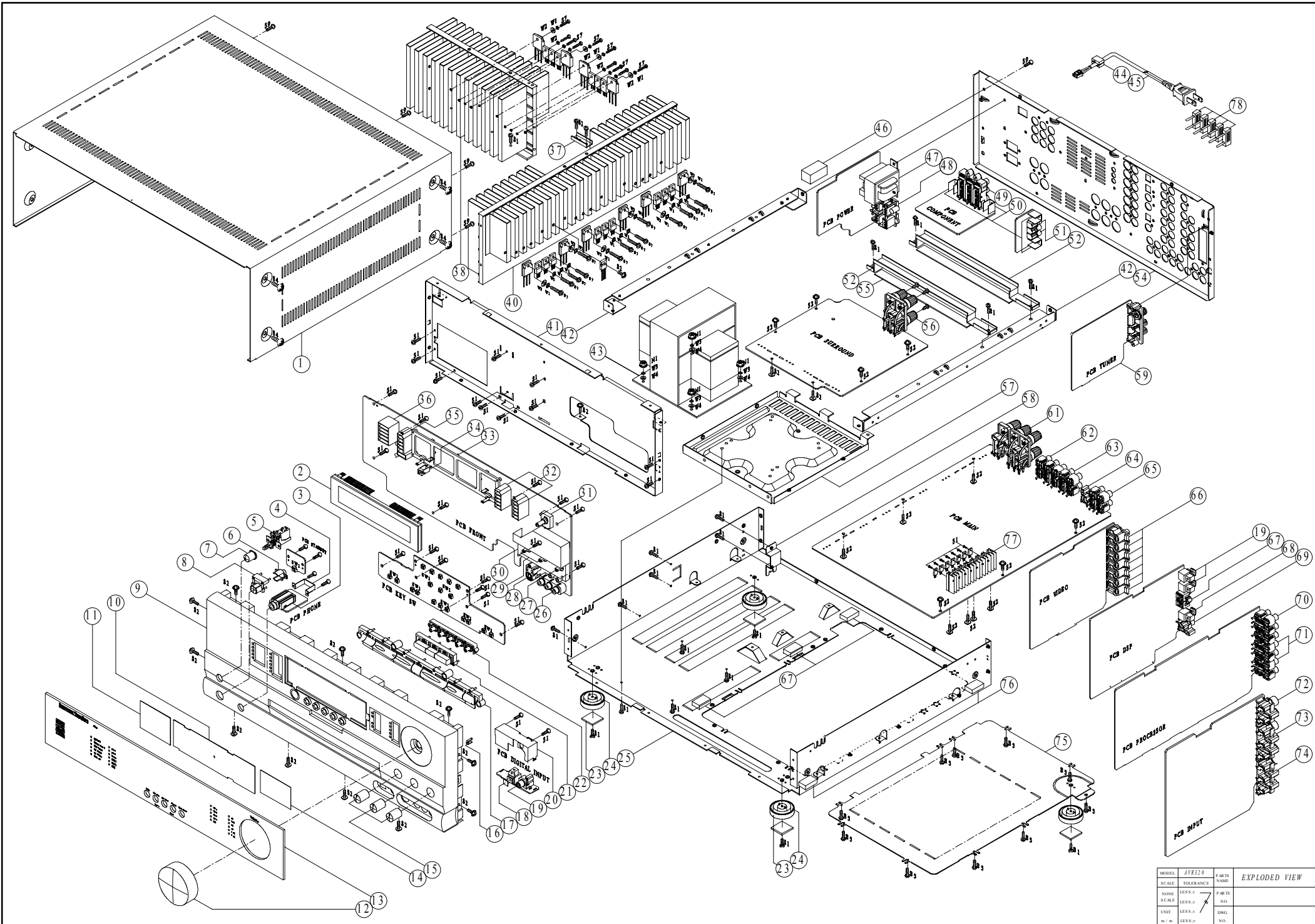

AVR 320 EXPLODED VIEW PART LIST

NO.	To com #	Q'TY	SName
1	55178050XX	1	AC PUN COVER TOP
2	55182450NR	1	DISPLAY VFD HNA- 16LL18
3	55088400XX	1	CONN- PHJAC 6.35 ST HORZ EST- J6313 BK 0 0
4	55124350XX	1	AC PUN BRACKET HEADPHONE
5	55178000NR	1	SW PUSH POWER SWITCH 5.0A 250.0V 100M00HM 1T 2P
6	55178020XX	1	AC MLD BUTTON INDICATOR STAND- BY
7	55177810XX	1	AC DEC BUTTON POWER
8	55177820XX	1	AC DEC BUTTON STANDBY
9	55206230XX	1	AC DEC CABINET PANEL FRONT AVR320
10	55177800XX	1	AC DEC CRYSTAL FILTER DISPLAY
11	55191560XX	1	AC NON- METAL DIFFUSER 0.2T 62.5*41 WH
12	55177740XX	1	AC DEC KNOB MAIN HIPS 94H
13	55198620XX	1	AC DEC CRYSTAL DISPLAY AVR320
14	55177990XX	1	AC NON- METAL DIFFUSER 0.2T 59.6*41 WH
15	55177750XX	3	AC DEC KNOB TONE
16	55178030XX	1	AC MLD BUTTON INDICATOR VIDEO 4
17	55177790XX	1	AC DEC BUTTON 7 KEY
18	55125440XX	3	D- LEM TOTX178B RD RND CL
19	55175240XX	1	CON PHONO SCKT RCA 1P W/ GND JE010003MG
20	55182550XX	1	AC PUN SHIELD DIGITAL ET
21	55177760XX	1	AC DEC BUTTON 3 KEY
22	55177780XX	1	AC DEC BUTTON 5 KEY
23	55174760XX	4	AC FOOT RUBBER ROUND 3.0MM 25.0MM JIS 60 Y DIA
24	55178110XX	4	AC FOOT ASSY ROUND 12.5MM 50MM
25	5517807BXX	1	AC CPL CABINET CHASSIS MAIN SECC 1.0T
26	55113740XX	1	CON PHONO SCKT RCA- 307 3 PINS
27	5517991000	2	PR- ROT 100K0 OHM NON- LINEAR RK14K12400BQ 0 0
28	55113960XX	1	CON DIN SCKT SOCKET CONNECTOR SVHS EST- S408J
29	5517992000	1	PR- ROT 100K0 OHM NON- LINEAR RK14K12400BR 0 0
30	55177570XX	1	AC PUN SHIELD FENCE TONE
31	55134900NR	1	SWIROT EC16B24204A5 5V 500U0A 10T 3P 0 0
32	55178940XX	2	AC PLASTIC MOLD REFRACTOR E WH
33	55178440XX	1	AC MLD HOLDER FL- GUIDE
34	55155930NR	1	IC- REMOTE RPM6938- RSIP- A3 RECEIVER 38KHZ
35	55177960XX	1	AC PLASTIC MOLD REFRACTOR C WH
36	55178930XX	1	AC PLASTIC MOLD REFRACTOR F WH
37	55255710XX		AC PUN BRACKET HEATSINK SECC1.2T
38	55199210XX	1	AC METAL HEATSINK(SURR)
39	BLANK		
40	55199200XX	1	AC METAL HEATSINK(MAIN)
41	55178250XX	1	AC CPL CABINET CHASSIS FRONT SECC 1.0T
42	55178170XX	2	AC PUN BRACKET FRAME- GUIDE SECC T1.0
43	55199320NR	1	TF- LAM POWER- TRANSFORMER 120V
44	55125180XX	1	AC MLD CLAMP AC CORD
45	55188980XX	1	WIRE- MCRDM 0.75MM2 1830MM BK CORD POWER CE
46	55178400XX	1	AC BUFFER CUSHION (A) EVA
47	55201700NR	1	TF- LAM POWER- TRANSFORMER 120V
48	55206550NR	1	CONN- SPE AC OUTLET 2P 110V FE 12.75MM 2 BK 0 0
49	55176360XX	1	CON PHONO SCKT RCA 9P W/ GNDCAP JK090122LN
50	55176420XX	4	AC PUN BRACKET BKT GROUND ET 0.5T
51	55176390XX	3	CON PHONO SCKT STEREO JACK JW350S
52	55178230XX	2	AC PUN BRACKET PCB

53	BLANK		
54	55198650XX	1	AC CPL REAR PANEL AVR320
55	55178300XX	3	AC BUFFER CUSHION- BRK'T EVA
56	55191390XX	1	CONN- SPE TERMINAL SPKR 4P SH0410376P
57	5517809AXX	1	AC PUN COVER TRANS BOTTOM T1.0
58	55262430XX	1	AC PUN BRACKET PROTECT
59	55177300XX	1	AC MSA ASY KST- M1114MW1- 60 TU MODULE
60	BLANK		
61	55191400XX	1	CONN- SPE TERMINAL SPKR 6P
62	55191420XX	1	CON PHONO SCKT RCA 4P JW- 4104RSA
63	55191480XX	1	CON PHONO SCKT RCA 6P JW- 4105RSB
64	55191370XX	1	CON PHONO SCKT RCA 1P JACK JE010003XN
65	55176330XX	1	CON PHONO SCKT RCA 4P JW4104RS GND
66	55149520XX	7	CON DIN SCKT MIX SOCKET RCA- 118JP1S
67	55191600XX	1	CON PHONO SCKT RCA 2P W/ GNDCAP JW- 1502SN OO
68	55125440NR	1	D- LEM TOTX178B RD RND CL
69	55175950XX	1	CON PHONO SCKT RCA 1P W/ GND JE010003MN
70	55176350XX	1	CON PHONO SCKT RCA 6P JW- 4105RSS W/ GNDCAP
71	55176330XX	1	CON PHONO SCKT RCA 4P JW4104RS GND
72	55207740XX	1	CON PHONO SCKT RCA 2P JE021163TN BRN/ TAN
73	55195480XX	1	CON PHONO SCKT RCA 2P JACK JE021163MN GY,GN
74	55195490XX	1	CON PHONO SCKT RCA 3P JACK JE031164TN WH,RD,BU
75	55178080XX	1	AC PUN COVER BOTTOM SECC T1.0
76	55125220XX	11	AC BUFFER PCB
77	55176400XX	1	AC METAL HEATSINK REG 118*20*50H
78	55182890NR	5	CONN- SPE JUMPER PLUG 2PIN
79	BLANK		
80	BLANK		
XX	55178960XX	1	AC SPRING PLATE SPRING GND C5212 0.2T
XX	55148840NR	1	FCORE FERRIT MAGNET RING34 34.5X21X12 K- 150
XX		1	
S1	55127070XX	64	SCREW- ST 3MM 10MM
S2	55127120XX	31	SCREW- ST 3MM 8MM
S3	55309240XX	4	SCREW- SPEC 4MM 10MM
S4	55127090XX	8	SCREW- ST 4MM 8MM
S5	55127280XX	10	SCREW- ST 3MM 6MM
S6	55164800XX	1	SCREW 3MM 8MM
S7	55178320XX	25	SCREW- ST 3MM 12MM
S9	55135460XX	59	SCREW- SPEC 3MM 10MM
N1	55309350XX	4	NUT- HEXAGON 4.0MM 5.0MM CIRCULAR EXTERNAL 53
W1	55127300XX	15	WASHER- SPRING 3
W2	55127310XX	10	WASHER- FLAT 3
W3	55168690XX	4	WASHER- SPRING 4
W4	55131730XX	4	WASHER- FLAT 4
L1	20932870XX	2	AC PRI LABEL QC CHECK CRKD1217(20X13MM)
L2	55149150XX	2	AC PRI LABEL RISK
L3	55174780XX	1	AC PRI LABEL DATE
L4	55198660XX	2	AC PRI LABEL SERIAL AVR320
L5	55198670XX	2	AC PRI LABEL BARCODE AVR320
L6	55178620XX	1	AC PRI LABEL "PLEASE REMOVE..."

harman/kardon**Service Bulletin**

Service bulletin # H/K2002-03 April 2002

Warranty labor rate: MINOR repair

To: All harman/kardon Service Centers

Model: AVR320

Subject: Transformer Hum or Buzz

In the event you receive an AVR320 with the complaint "There is a hum or buzz sound coming from the unit", first confirm the sound is coming from the receiver itself and not at the loudspeaker output, then replace the Power Transformer:

- 1) Remove the top cover (14 Phillips screws)
- 2) Locate the Power Transformer; it is attached with (4) Phillips screws.
- 3) All connectors terminating the cable harness consisting of multiple conductors need to be unplugged from two main locations. Remove all plastic ties necessary to remove the harness. Most connectors have "tabs" on one side that should be depressed before the connector can be unplugged.

CN402	6 conductor – small - molex	MAIN PCB near DC fuse bank - front of unit
CN401	2 conductor – large - tab	MAIN PCB near DC fuse bank - front of unit
WA603	3 conductor – large - tab	Power Supply section – rear of unit near bridge rectifier
WA985	2 conductor – large - tab	Power Supply section – rear of unit near bridge rectifier (Access to this connector may be made easier by removing the Component Video PCB (4 Phillips screws) and pulling the board, with cables attached, out of the unit)

- 4) Remove and replace the Power Transformer with h/k part# 55199320XX.
- 5) Replace the harness, add new cable ties, plug in all connectors, (replace Component Video PCB if it was removed): replace the top cover.
- 6) Test the unit and confirm the hum or buzz is no longer present.

Model	Serial Number (120v)	Status	Action
AVR320	TH0044-01000 to TH0044-03854		None Required
AVR320	TH0044-03855 To TH0044-08419	Hum or Buzz from Power Transformer	Replace Power Transformer
AVR320	TH0044-08420 and above		None Required

harman/kardon

Service Bulletin

Service bulletin # H/K2002-07 October 2002

Warranty labor rate: MINOR repair

To: All harman/kardon Service Centers

Model: AVR320

Subject: Intermittent Output

In the event you receive an AVR320 receiver with the complaint “There is intermittent output from the receiver”, follow the instructions below:

All sources, all modes may be affected, using any audio connections; unit may also not turn off with the system power control.

- 1) Turn the unit on it’s side so the bottom panel faces you, and the access cover (grille) is at the top. Remove the (9) Phillips screws holding the access cover on; one “foot” will come off with the cover.
- 2) Locate and inspect all soldered connections on the Main PCB, particularly in the area of connector CN411 and CN410, the 15 pin horizontal foil patterns (see illustration).
- 3) Repair as needed with solder or buss wire.
- 4) Test the unit, replace the access cover (grille).

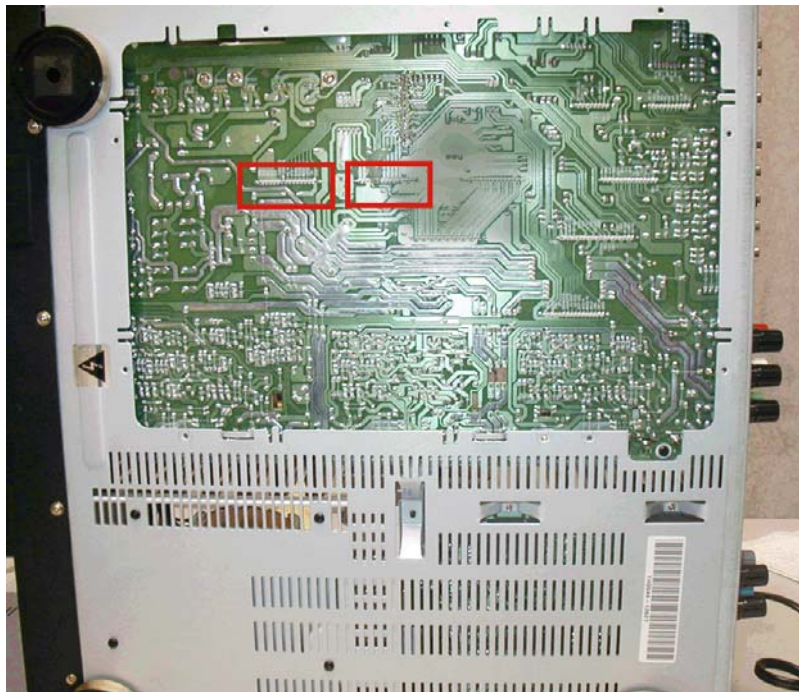

MODEL	SERIAL NUMBER 120V	STATUS	ACTION
AVR320	All serial numbers affected	Connections may need repair or re-soldering	Check for broken connections and sufficient solder on Main PCB

harman/kardon

Service Bulletin

Service bulletin # H/K2003-07 Sept. 2003

Warranty labor rate: MINOR repair

To: All harman/kardon Service Centers

Model: AVR110/210/310/510, AVR120/220; AVR320/520

Subject: Various Complaints

For Complaints:

NO AUDIO
NOISE
INTERMITTENT NOISE
INTERMITTENT AUDIO

Possible Solution:

Voltages may be too high on DSP Buffer IC or DSP IC

All modifications are done to the DSP board.

AVR110/210/310/510 AVR120/220

Remove BD5 and replace with two 1N4148 diodes in series.
Remove R43 and R90 (3.3Ω) and replace each with a 1N4148 diode.
(See diagram Page 2 for location and polarity)

AVR320/520

Remove BD25 and replace with two 1N4148 diodes in series.
(See diagram Page 2 for location and polarity)

In all cases the 1N4148 diode(s) you need to add should be normal 2-lead axial components, like h/k part# 13-0482 or equivalent (not SMD devices).

MODELS: AVR110/210/310/510
AVR120/220

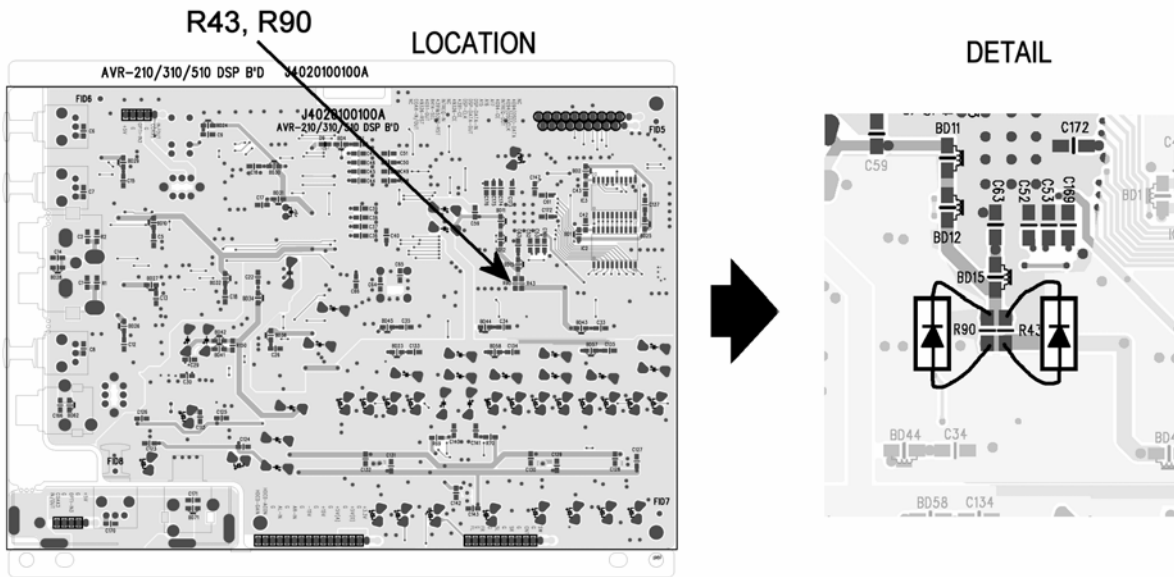
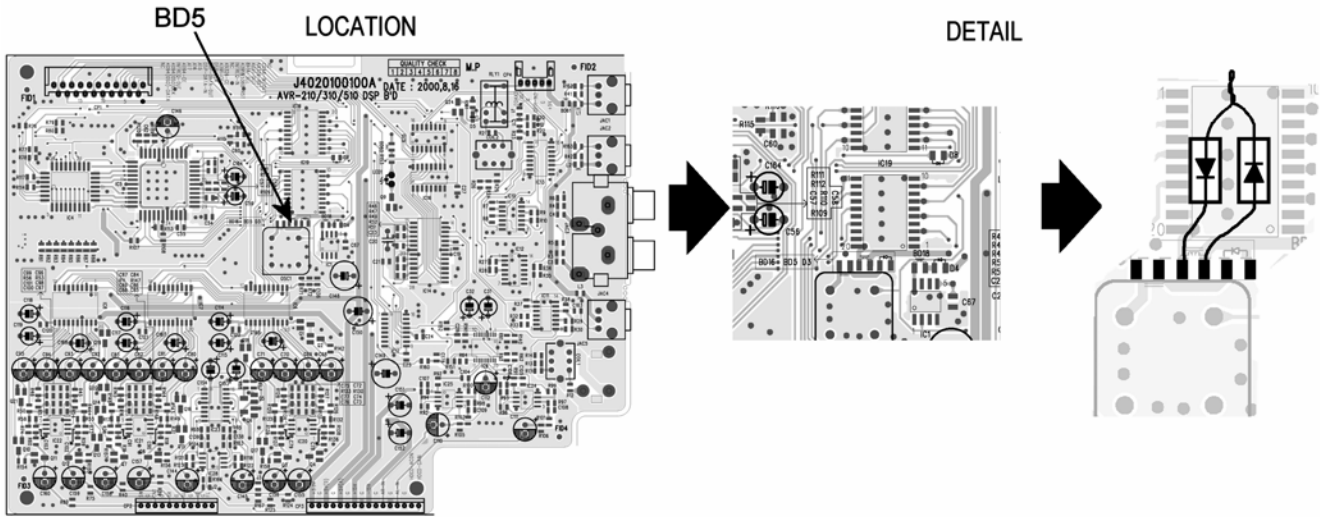

MODELS: AVR320/520

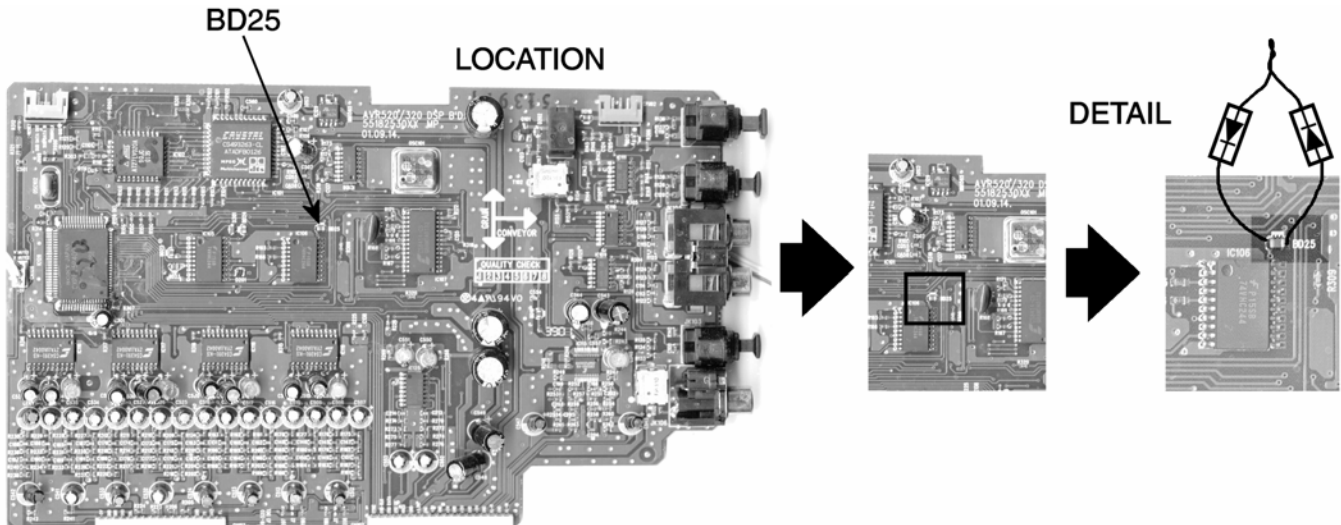

harman/kardon**TECH TIPS****Troubleshooting tips and solutions to common service problems**

For models:

TIP# HKTT2003-01 Rev5

AVR7000/7200/7300/8000	AVR10
AVR100/200/300/500	DPR1001
AVR110/210/310/510	DPR1005
AVR120/220/320/520	DPR2005
AVR125/225/325/525	HK3370/3470/3375/3475
AVR130/230/330/430/630	HK3250
AVR135/235/335/435/635	

Subject: Backup Memory on AVR/DPR/HK series receivers

In the event of the complaint: “the receiver is losing its memory (any programmed system settings) when the unit is turned off, or after the unit is unplugged (briefly*)”:

Check and replace:

Model	Designator	Location	Description	Part number
AVR10	C712 D709	Front PCB	0.047 Farad 5.5v capacitor and 1N4148 diode	#3439247315 #2058322101
AVR7000	C730	Front PCB	0.047 Farad 5.5v capacitor	# P10790-ND or # J3432147324X
AVR7200	C106	Front PCB	0.047 Farad 5.5v capacitor	# P10790-ND
AVR7300	C657	DSP PCB	0.047 Farad 5.5v capacitor	# H01-CEZXA0479MN-5
AVR8000	C726	Front PCB	0.047 Farad 5.5v capacitor	# 55230310NR or # P10790-ND
AVR100/200	C412	Front PCB	0.047 Farad 5.5v capacitor	# CEGT-B473J-0J0
AVR300	C906	Front PCB	0.1Farad 5.5v capacitor	# J4433210421X or # P10791-ND
AVR500	C906	Front PCB	0.1Farad 5.5v capacitor	# J4433210421X or # P10791-ND
AVR110/210/310/510 AVR120/220/320/520	C216	Front PCB	0.047 Farad 5.5v capacitor	# P10790-ND
AVR125/225	C734,C885	Front PCB	two 0.1F capacitors in parallel	# BCESOHD104
AVR325/525	C106	Front PCB	0.047 Farad 5.5v capacitor	# P10790-ND
AVR130/230/330	BAT1	Front PCB	3.6v Battery	# HABGP40BVH3A3H
AVR135/235/335	BAT1	Front PCB	3.6v Battery	# HGP15BNH3A3H
AVR430/630	C657	DSP PCB	0.047 Farad 5.5v capacitor	# CEZXA0479MN-5
AVR435/635	C557	DSP PCB	0.047 Farad 5.5v capacitor	# H03-CEZXA0479MN-0
DPR1001	BC601	Main PCB	0.1Farad 5.5v capacitor	# CEGT-B104J-0J0
DPR1005/2005	C437	Processor PCB	0.047 Farad 5.5v capacitor	# CEZXA0479MN-5
HK3370/3470	C301	Front PCB	0.1Farad 5.5v capacitor	# CEGT-B104J-0J0
HK3375/3475	C301	Front PCB	0.1Farad 5.5v capacitor	# CEGT-B104J-0J0
HK3250	C712 D709	Front PCB	0.047 Farad 5.5v capacitor and 1N4148 diode	#3439247315 #2058322101

* After approximately two weeks of being disconnected from AC supply, even a normally functioning receiver may lose any programmed settings and switch to default settings. (Four weeks for the DPR1005 & 2005)

harman/kardon**TECH TIPS****Troubleshooting tips and solutions to common service problems****TIP# HKTT2004-03**

Isolating audio problems in an AVR receiver Using 6/8 Direct In

The following charts are used to help the tech quickly isolate audio problems in an AVR receiver. Use the following procedures to help find what is working, then to quickly locate the problem area.

Equipment needed:

- ✓ 1 set of (RCA) Y adaptors.
- ✓ Function/signal generator.
- ✓ Oscilloscope.

Models covered:	
AVR210	AVR310
AVR220	AVR320
AVR520	AVR225
AVR125	AVR525
AVR130	AVR230
AVR330	AVR430
AVR630	

Procedure:

- 1) Do a factory reset of the receiver. (This will eliminate any common micro processor problems.) Reset List can be found in this service manual.
- 2) Print the block diagram from the service manual.
- 3) With no inputs or speakers attached to the AVR turn on the receiver and turn the volume all the way down.
- 4) Turn unit off.
- 5) Hook up an oscillator to the 6/8 Direct in jacks using the Y adaptors. Adjust the oscillator to about 0db (.775Volts RMS).
- 6) Hook up an oscilloscope to monitor the line out jacks. Or, if there are no line out (preamp out) jacks monitor the input to the power amps or the speaker outs. (AVR125, 225, 130 do not have preamp out jacks)
- 7) Turn the AVR on. Select 6 or 8 direct in, depending on the receiver.
- 8) Slowly turn the volume control up until you can easily measure the voltage at the line out jacks. (-40 to -25db)

Isolating audio problems in an AVR receiver Using 6/8 Direct In

- 9) At this point you will be able to check and assure all output levels are the same.
- 10) IF THE OUTPUT LEVELS ARE NOT THE SAME STOP! Go no further. At this point you will need to use the charts to see where you are losing your signal. The chart shows the analog signal flow from the input jacks to the output jacks.
- 11) If the output levels are the same check the power out stage at the speaker out jacks.
- 12) If you find the levels at the speaker out jacks are OK, your problem will be in the DSP part of the receiver.

Congratulations! You have now eliminated 90% of the electronics in the AVR and confirmed that the problem is in the DSP section.

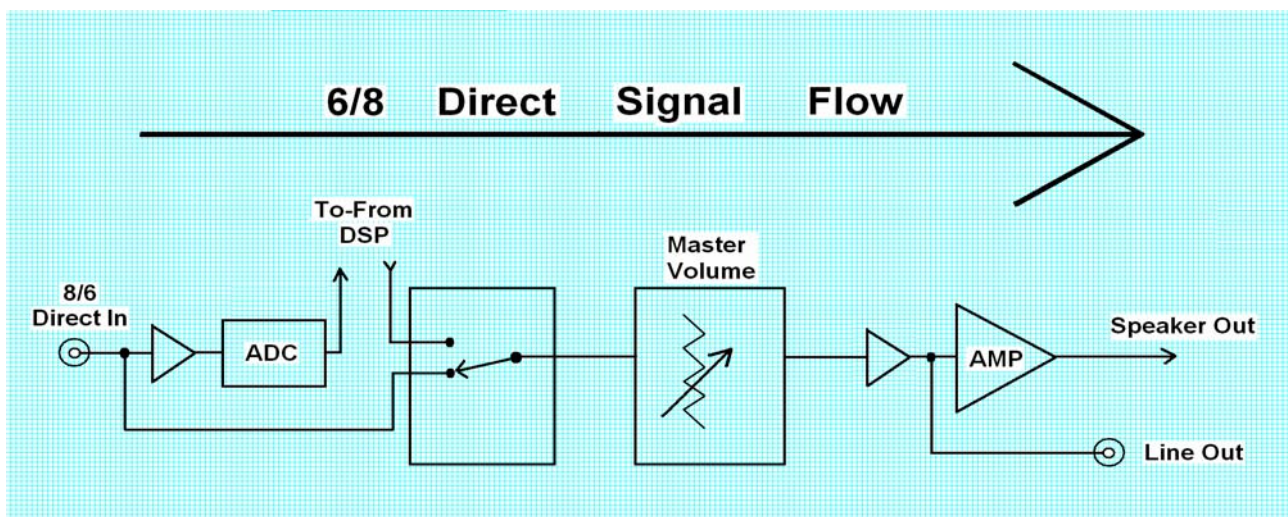

Isolating audio problems in an AVR receiver Using 6/8 Direct In

AVR,210,310,510

6 CH IN	IC 501 In	IC 501 Out	CN 408	IC 704 In	IC 704 Out	IC 705 In	IC 705 Out	IC 706 In	IC 706 Out	IC 705 In	IC 705 Out	IC 716 In	IC 716 Out	IC 717 In	IC 717 Out	IC 718 In	IC 718 Out	CP 405
FR	3	1	15	2	4	8	9	4	3	19	17	3	1					3
FL	5	7	13	27	25	21	20	25	26	10	12	5	7					1
SR			11	5	7			7	6				5	7				9
SL			9	24	22			22	23				3	1				7
C			5	21	19			19	20							3	1	5
SW			7	8	10			10	9						5	7	11	

AVR220

6 CH IN	IC 501 In	IC 501 Out	CN 408	IC 704 In	IC 704 Out	IC 705 In	IC 705 Out	IC 706 In	IC 706 Out	IC 714 In	IC 714 Out	IC 705 In	IC 705 Out	IC 716 In	IC 716 Out	IC 717 In	IC 717 Out	IC 718 In	IC 718 Out	CP 405
FR	5	7	15	2	4	8	9	4	3	5	7	10	12	5	7					1
FL	3	1	13	27	25	21	20	25	26	3	1	19	17	3	1					3
SR			11	5	7			7	6							5	7			9
SL			9	24	22			22	23							3	1			7
C			5	21	19			19	20									3	1	5
SW			7	8	10			10	9									5	7	11

AVR320/520

8 CH IN	IC 501 In	IC 501 Out	CN 408	IC 704 In	IC 704 Out	IC 705 In	IC 705 Out	IC 706 In	IC 706 Out	IC 714 In	IC 714 Out	IC 705 In	IC 705 Out	IC 716 In	IC 716 Out	IC 717 In	IC 717 Out	IC 718 In	IC 718 Out	CP 405
FR	5	7	15	2	4	8	9	4	3	5	7	10	12	5	7					1
FL	3	1	13	27	25	21	20	25	26	3	1	19	17	3	1					3
SR			11	5	7			7	6							5	7			9
SL			9	24	22			22	23							3	1			7
C			5	21	19			19	20									3	1	5
SW			7	8	10			10	9									5	7	11
			CN418	CP102	IC101 In	IC101 Out	IC102 In	IC102 oUT	ic103 in	ic103 Out										
SBR	3	3	3	4	21	23	5	7												
SBL	1	1	25	26	4	2	3	1												

AVR225/125

6 CH IN	IC 30 In	IC 30 Out	IC 31 In	IC 31 Out	IC 32 In	IC 32 Out	IC 33 In	IC 33 Out	IC 34 In	IC 34 Out	BN12	IC 81 In	IC 81 Out	IC 80 In	IC 80 Out	BN16 In	BN16 Out
L ch	27	25	19	20	5	7					1	3	1	9	10	1	2
R ch	24	22	22	23	3	1					3	5	7	15	14	4	5
SL	5	4	7	6					5	7	9						
SR	2	4	10	9					3	1	11						
C	8	18	4	3			3	1			7						
SW	21	19	25	26			5	7			5						

Isolating audio problems in an AVR receiver

Using 6/8 Direct In

AVR 525

In Jack	N404	P6	IC5 In	IC5 Out	IC3 In	IC3 Out	IC19 In	IC19 Out	IC18 In	IC20 In	IC20 Out	IC3 In	IC3 Out	IC18 Out	IC23 In	IC23 Out	IC25 In	IC25 Out	IC24 In	IC24 Out	IC26 In	IC26 Out	P9	N806
FL	1	1			10	9			4	2	3	1	3	5	3	1							1	1
FR	3	3			21	22			21	23	5	7	28	6	6	7							3	3
SL	5	5	2	4			4	3									3	1					5	5
SR	7	7	29	27			25	26									5	7					7	7
CTR	9	9	5	7			7	6											3	1			9	9
SW	11	11	26	24			22	23											5	7			11	11
SBL	13	13	8	10			10	9													3	1	13	13
SBR	15	15	23	21			19	20													6	7	15	15

AVR130

6 ch in	IC 23 In	IC 23 Out	IC 26 In	IC 26 Out	IC 42 In	IC 42 Out	IC 44 In	IC 44 Out	IC 43 In	IC 43 Out	IC 40 In	IC 40 Out	IC 49 In	IC 49 Out	BN 12	BN11
L	18	17			21	23									1	
R	19	12			4	2										14
SL			24	22			21	23							9	
SR			5	7			4	2							7	
C			27	25			21	23							5	
SUB			2	4			4	2							3	
SBL			21	19					21	23	5	7	13			
SBR			8	10					4	2	3	1	11			

AVR230/330

6 ch in	IC 23 In	IC 23 Out	IC 26 In	IC 26 Out	IC 42 In	IC 42 Out	IC 44 In	IC 44 Out	IC 43 In	IC 43 Out	IC 40 In	IC 40 Out	IC 49 In	IC 49 Out	BN 12	BN11
L	18	17			21	23									1	
R	19	12			4	2										14
SL			24	22			21	23							9	
SR			5	7			4	2							7	
C			27	25			21	23							5	
SUB			2	4			4	2							3	
SBL			21	19					21	23	5	7	13			
SBR			8	10					4	2	3	1	11			

AVR630/430

8 CH In	N404	IC 3	IC 3 Out	IC 14 In	IC 14 Out	IC 12 In	IC 12 Out	IC 3 In	IC 3 Out	IC 27 In	IC 27 Out	IC 18 In	IC 18 Out	IC 20 In	IC 20 Out	IC 3 In	IC 3 Out
FL	1	10	12	10	9	3	1	6	9	3	1	4	2	3	1	3	1
FR	3	19	17	19	20	5	7	23	20	5	7	21	23	5	7	26	7
SL	5	2	4	4	3	3	1										
SR	7	27	25	25	26	5	7										
CTR	9	5	7	7	6			3	1								
SW	11	24	22	22	23			5	7								
SBL	13	8	10	10	9					3	1						
SBR	15	21	19	19	20					5	7						

Idle Adjustment Procedure

1. MAIN B'D

Turn POWER ON and wait 10 minutes, set controls VR401,VR402,VR501 in order to make voltages on both ends of WA401,WA402,WA403 **20mV.** See locations below

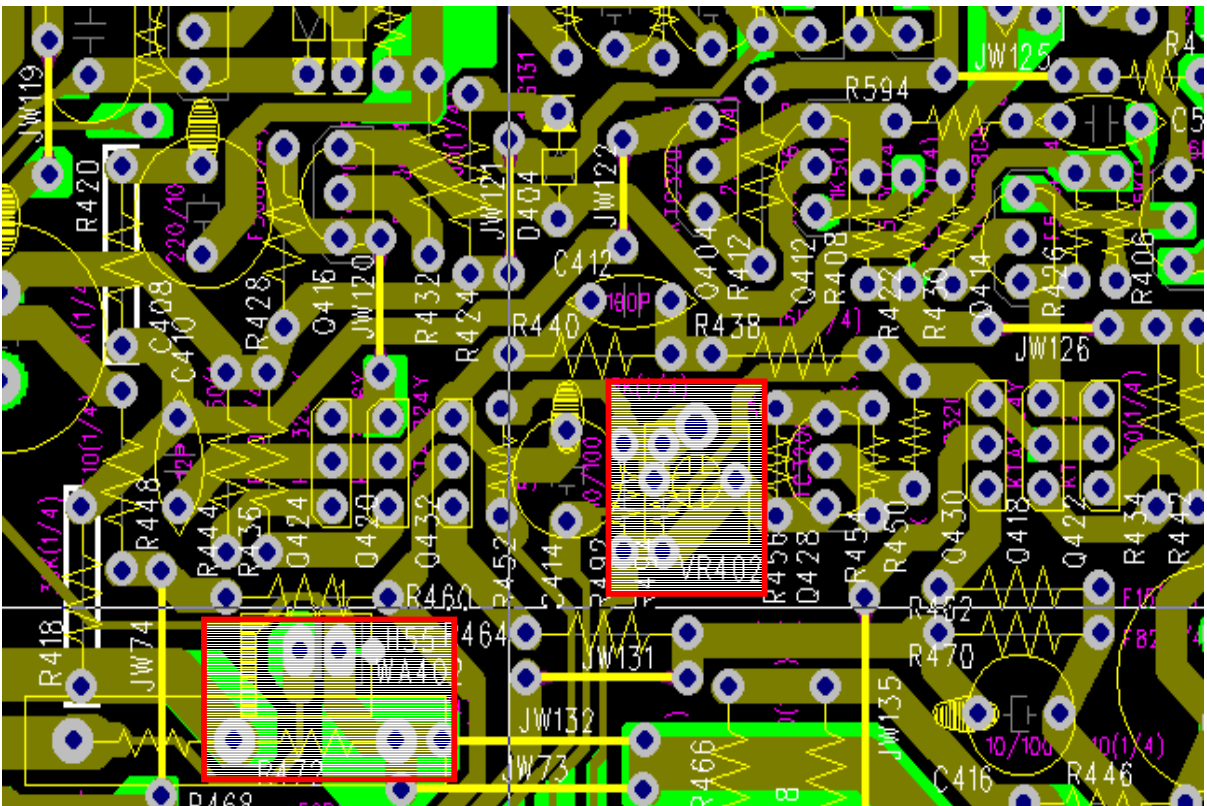
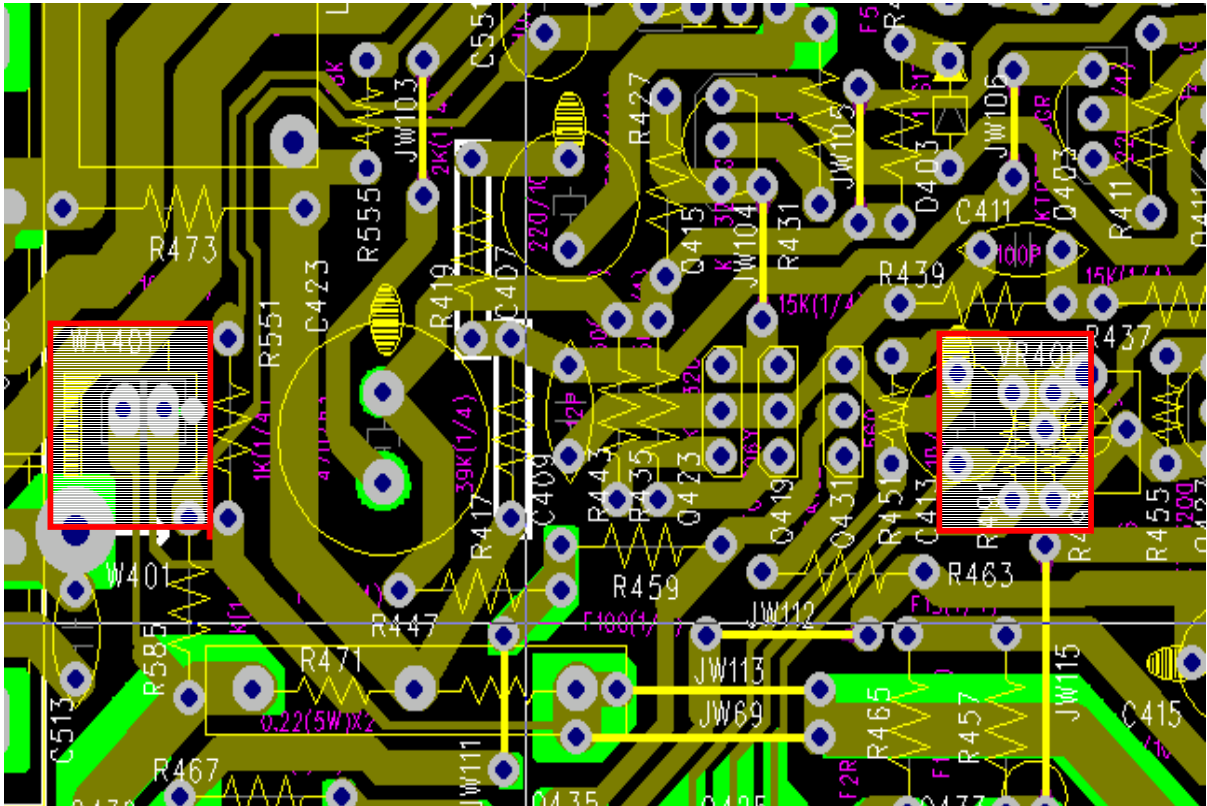

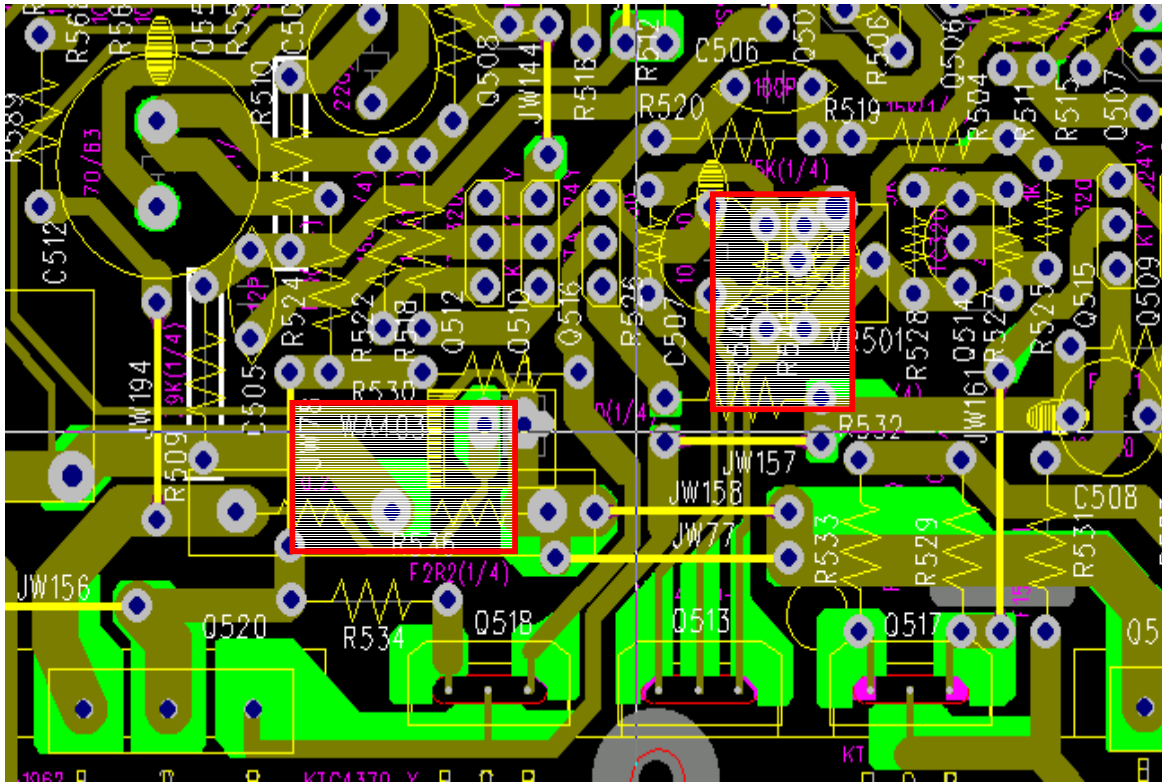

2. SURROUND B'D

Turn POWER ON and wait 10 minutes, set controls VR601,VR602 in order to make voltages on both ends of WA601,WA602 **20mV.** See locations below

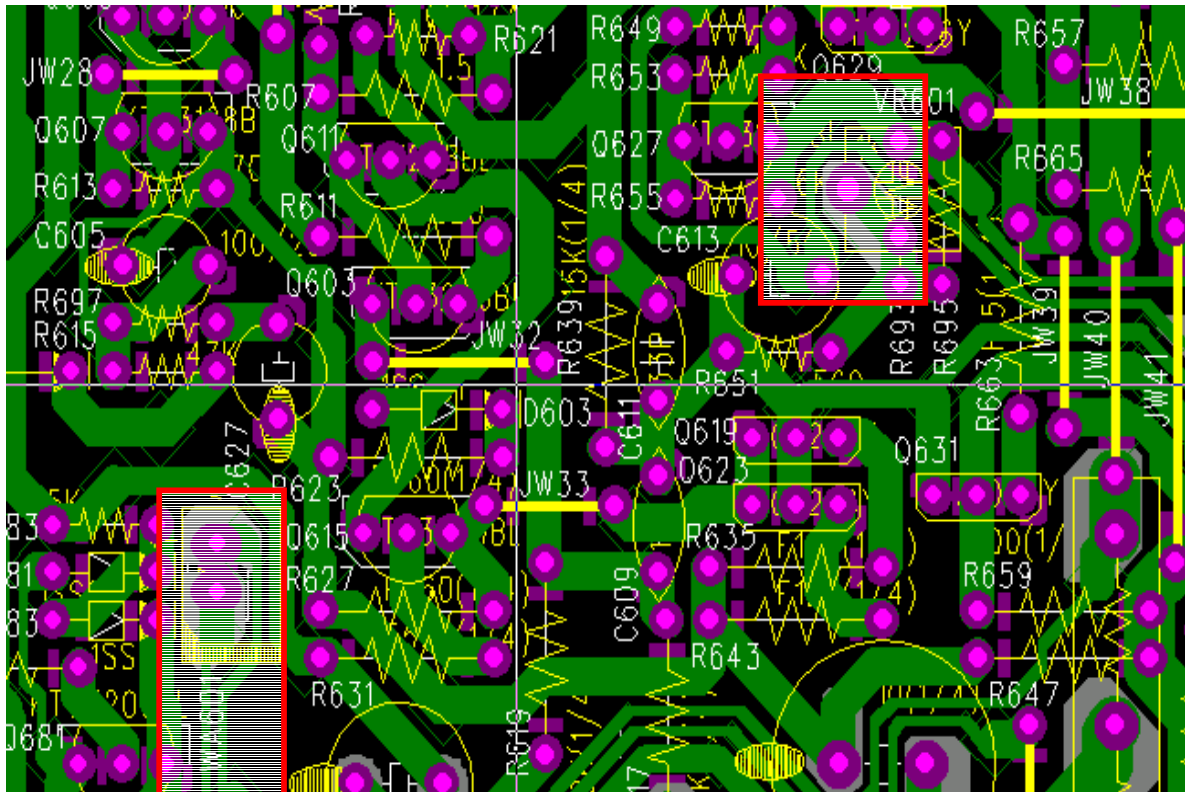

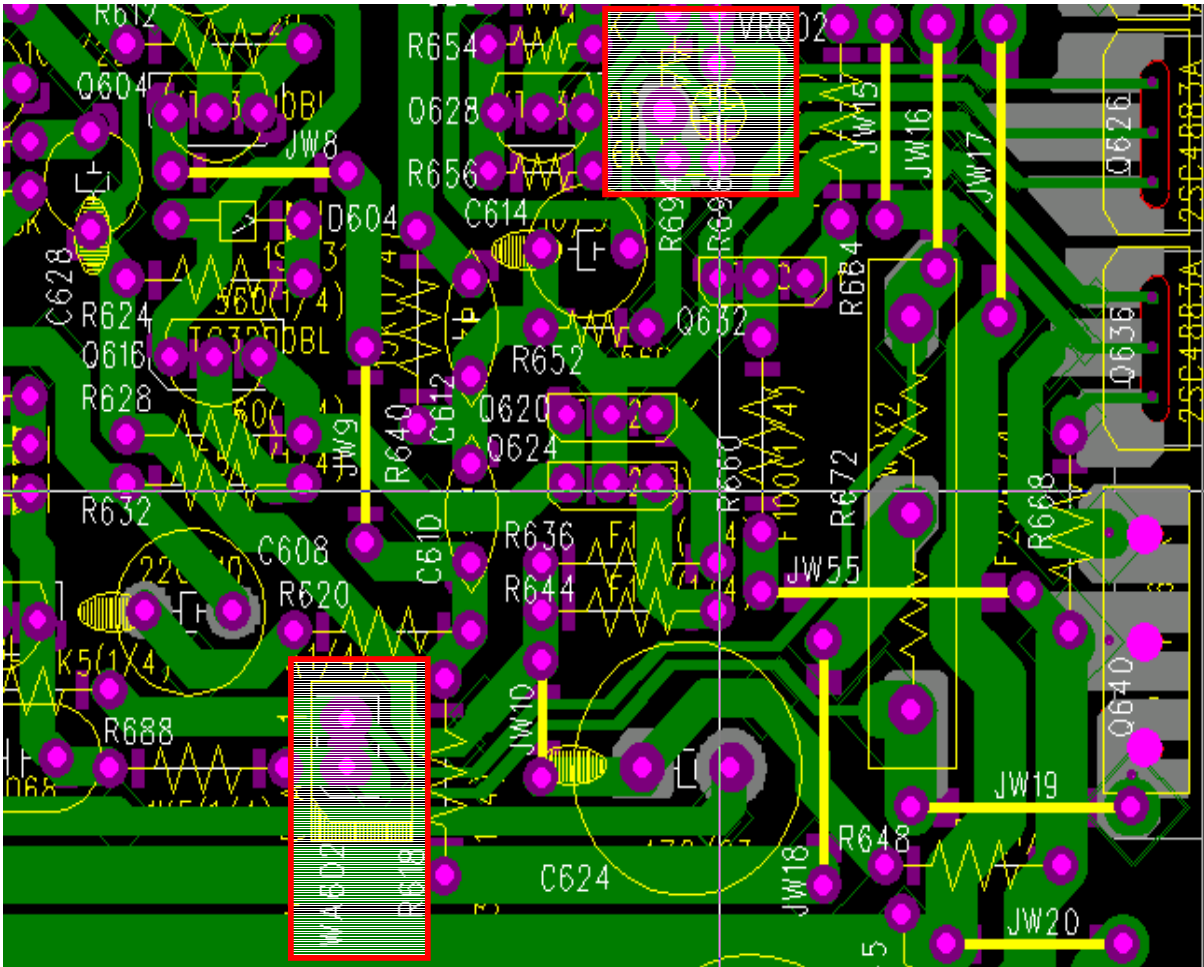

BLOCK DIAGRAM

MODEL: AVR320/520/4500/5500

3		2		1			
NO	DATE	POS.	CONTENTS	NO	DATE	POS.	CONTENTS

COMPONENT VIDEO

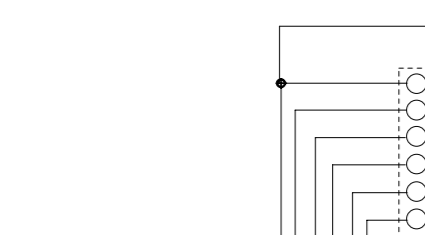
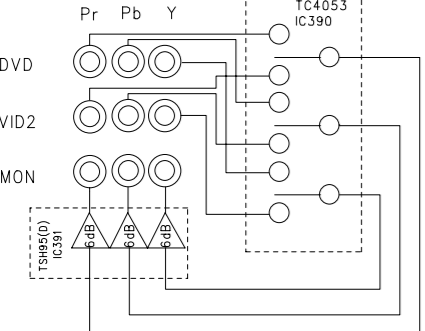

AUDIO

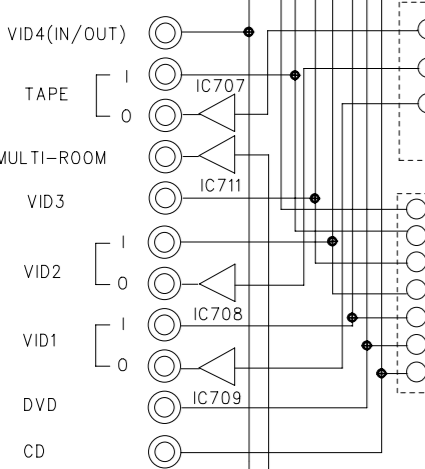

C-VIDEO/S-VIDEO

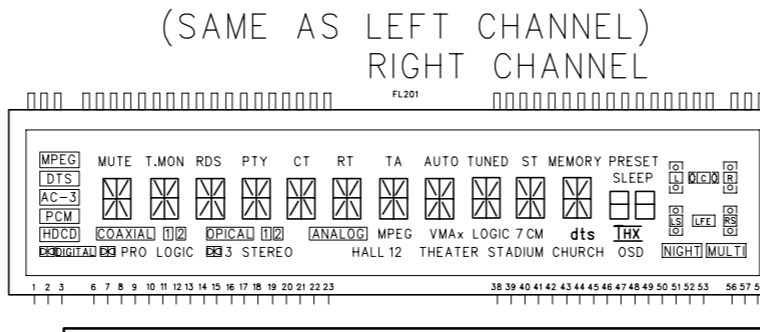
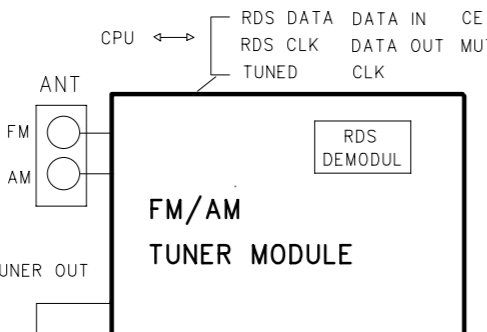
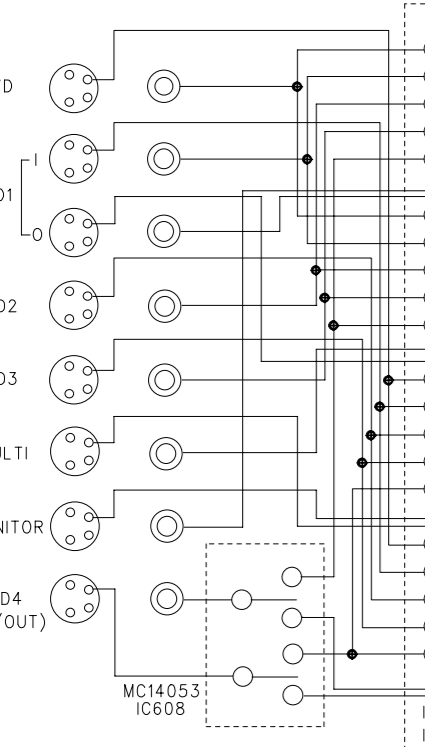

- TUNER PARTS
- DD/DTS PARTS
- MAIN AMP PARTS
- SUPPLY PART
- PRE PARTS
- VIDEO PARTS
- POWER SUPPLY PARTS

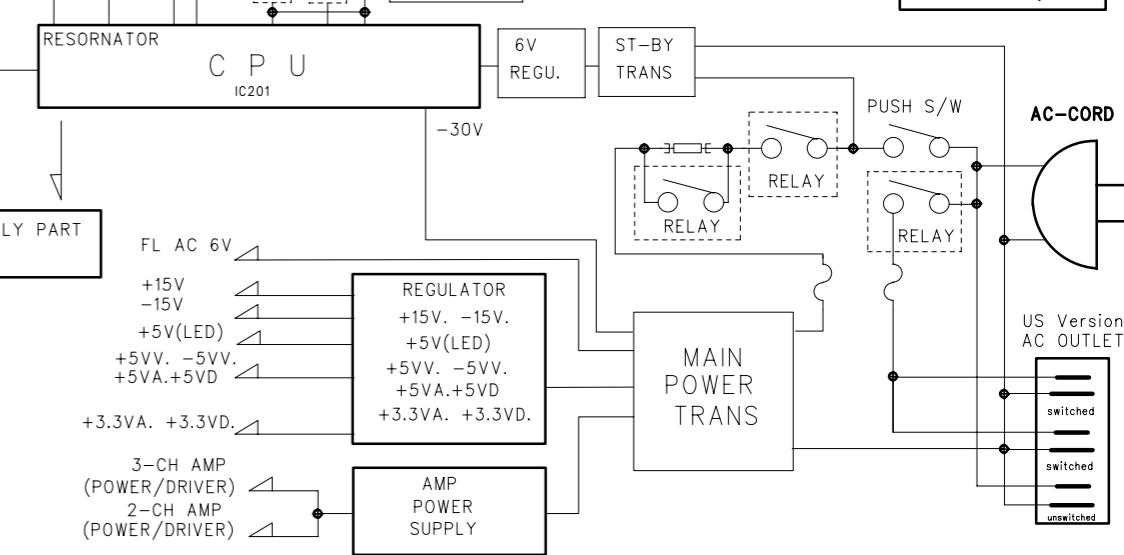
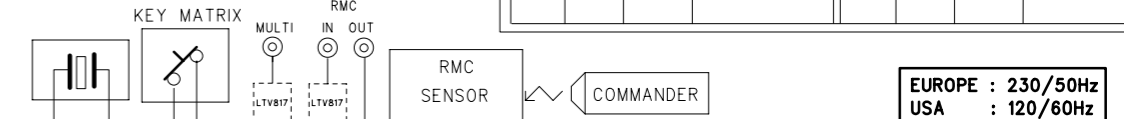
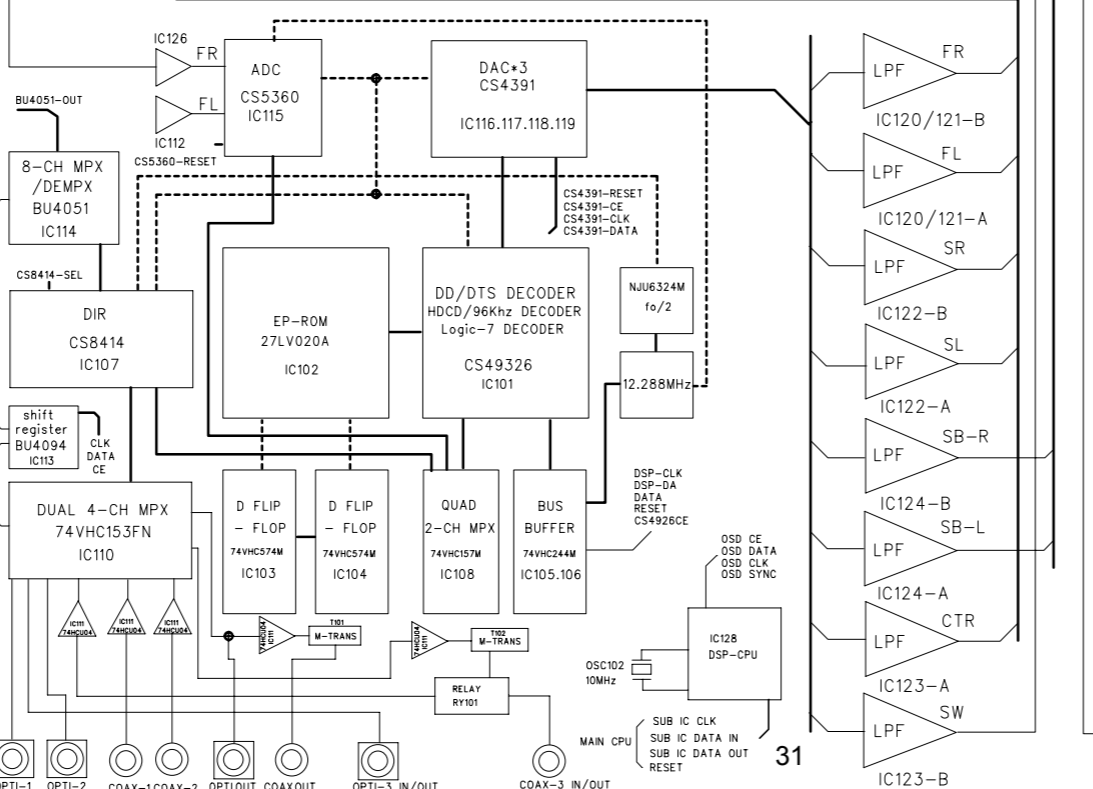
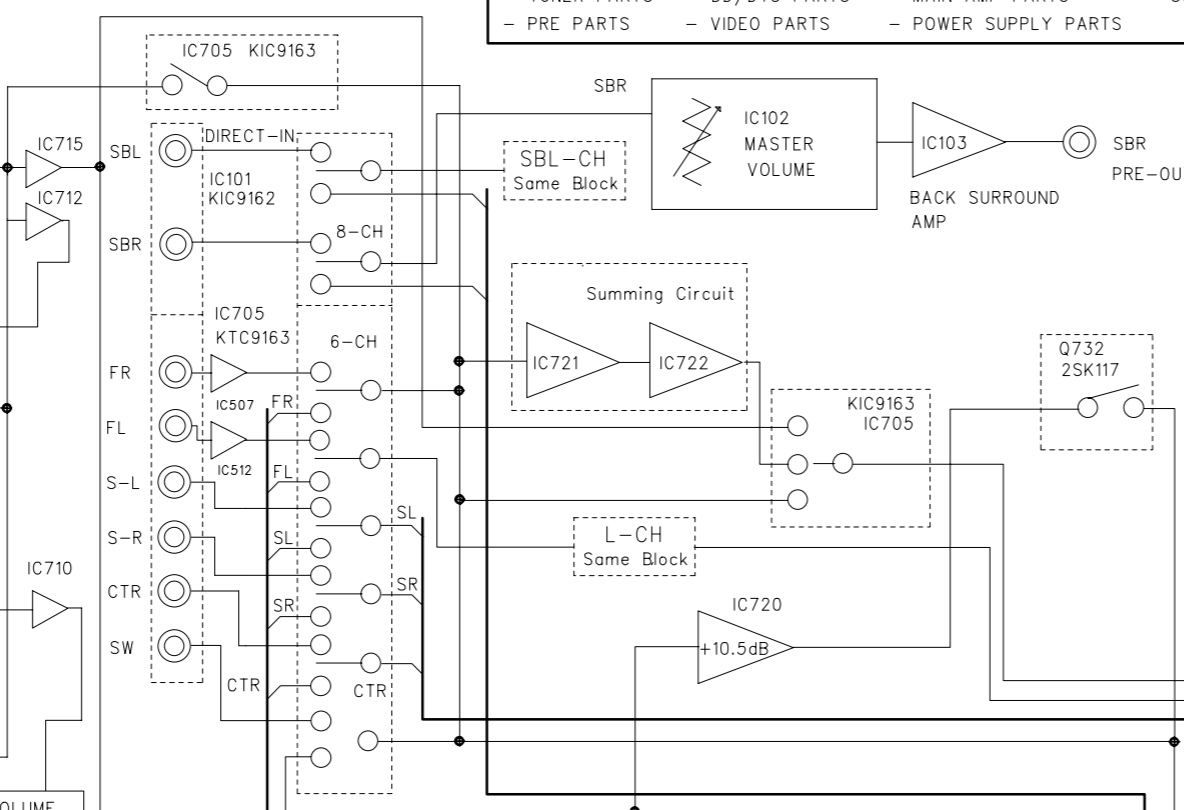

(SAME AS LEFT CHANNEL) RIGHT CHANNEL

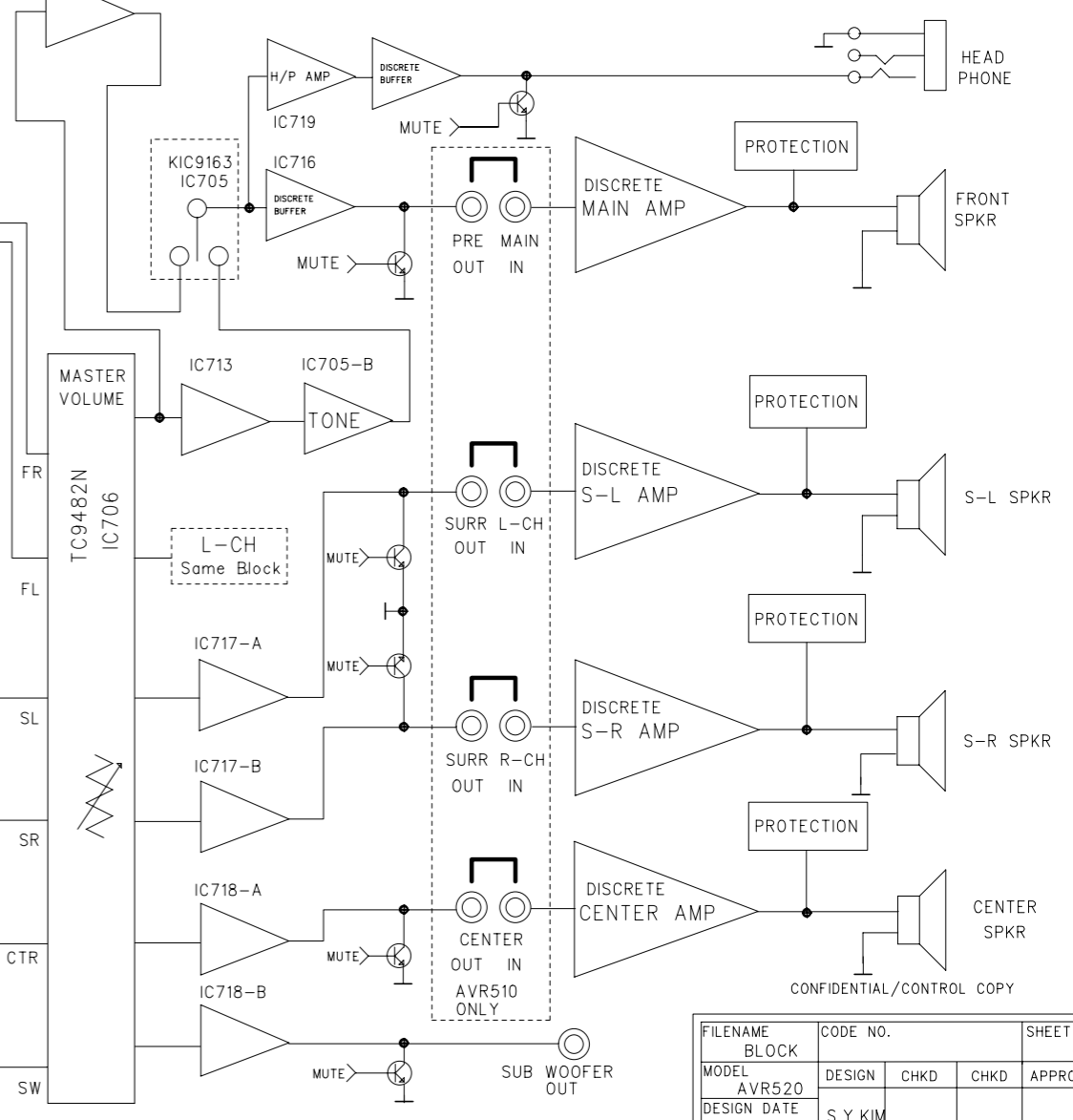

FILENAME	BLOCK	CODE NO.	SHEET
MODEL	AVR520	DESIGN	CHKD
DESIGN DATE	15.JAN.2002	S.Y.KIM	APPROVAL

AVR320 Electrical Parts List

Main PCB

Ref. Designator	Part Number	Qty	Description
<i>Capacitors</i>			
C101	2034206039 or 157D-476M-5-IU	1 PC	CE 47U0F +20% 16.0V 85C
C102	2034206039 or 157D-476M-5-IU	1 PC	CE 47U0F +20% 16.0V 85C
C103	15002130 or 1500213041 J3471610031X J3470110031X	1 PC	CE 10U0F +20% 16.0V 85C
C104	15002130	1 PC	CE 10U0F +20% 16.0V 85C
C105	J3513101270X	1 PC	CC 100P0F +10% -10% 50.0V Y5P
C106	J3513101270X	1 PC	CC 100P0F +10% -10% 50.0V Y5P
C107	J3513101270X	1 PC	CC 100P0F +10% -10% 50.0V Y5P
C108	J3513101270X	1 PC	CC 100P0F +10% -10% 50.0V Y5P
C109	20293470	1 PC	CC 100N0F +80% -20% 50.0V F
C110	J3513101270X	1 PC	CC 100P0F +10% -10% 50.0V Y5P
C111	J3513101270X	1 PC	CC 100P0F +10% -10% 50.0V Y5P
C112	J3513101270X	1 PC	CC 100P0F +10% -10% 50.0V Y5P
C113	J3513101270X	1 PC	CC 100P0F +10% -10% 50.0V Y5P
C115	20250040	1 PC	CC 220P0F +10% -10% 50.0V Y5P
C117	20250040	1 PC	CC 220P0F +10% -10% 50.0V Y5P
C118	20293470	1 PC	CC 100N0F +80% -20% 50.0V F
C119	J3513101270X	1 PC	CC 100P0F +10% -10% 50.0V Y5P
C120	J3513101270X	1 PC	CC 100P0F +10% -10% 50.0V Y5P
C121	J3513101270X	1 PC	CC 100P0F +10% -10% 50.0V Y5P
C122	J3513101270X	1 PC	CC 100P0F +10% -10% 50.0V Y5P
C123	20293470	1 PC	CC 100N0F +80% -20% 50.0V F
C124	20293470	1 PC	CC 100N0F +80% -20% 50.0V F
C125	J3513101270X	1 PC	CC 100P0F +10% -10% 50.0V Y5P
C126	J3513101270X	1 PC	CC 100P0F +10% -10% 50.0V Y5P
C127	20293470	1 PC	CC 100N0F +80% -20% 50.0V F
C128	J3513101270X	1 PC	CC 100P0F +10% -10% 50.0V Y5P
C129	J3513101270X	1 PC	CC 100P0F +10% -10% 50.0V Y5P
C130	J3513101270X	1 PC	CC 100P0F +10% -10% 50.0V Y5P
C131	20293470	1 PC	CC 100N0F +80% -20% 50.0V F
C401	1305550030	1 PC	CE 10U0F +20% 50.0V 85C
C402	1305550030	1 PC	CE 10U0F +20% 50.0V 85C
C403	11055300	1 PC	CC 68P0F +5% -5% 50.0V NP0
C404	11055300	1 PC	CC 68P0F +5% -5% 50.0V NP0
C405	20269070	1 PC	CE 100U0F +20% 25.0V 85C
C406	20269070	1 PC	CE 100U0F +20% 25.0V 85C
C407	20269080	1 PC	CE 220U0F +20% 10.0V 85C
C408	20269080	1 PC	CE 220U0F +20% 10.0V 85C
C409	30936070	1 PC	CC 12P0F +5% -5% 50.0V NP0
C410	30936070	1 PC	CC 12P0F +5% -5% 50.0V NP0
C411	60439150	1 PC	CC 33P0F +5% -5% 50.0V NP0
C412	60439150	1 PC	CC 33P0F +5% -5% 50.0V NP0
C413	1305550030	1 PC	CE 10U0F +20% 50.0V 85C
C414	1305550030	1 PC	CE 10U0F +20% 50.0V 85C
C415	1305550030	1 PC	CE 10U0F +20% 50.0V 85C
C416	1305550030	1 PC	CE 10U0F +20% 50.0V 85C
C417	55179360	1 PC	CPM 100N0F +10% 63.0V
C418	55179360	1 PC	CPM 100N0F +10% 63.0V
C419	55179360	1 PC	CPM 100N0F +10% 63.0V
C420	55179360	1 PC	CPM 100N0F +10% 63.0V
C425	11055540	1 PC	CC 2N2F +10% -10% 50.0V Y5P

Ref. Designator	Part Number	Qty	Description
C426	11055540	1 PC	CC 2N2F +10% -10% 50.0V Y5P
C431	10364820	1 PC	CPF 47N0F +10% 100.0V
C432	10364820	1 PC	CPF 47N0F +10% 100.0V
C433	10364820	1 PC	CPF 47N0F +10% 100.0V
C483	55095430	1 PC	CPM 100N0F +10% 250.0V
C484	10364820	1 PC	CPF 47N0F +10% 100.0V
C489	1305550030	1 PC	CE 10U0F +20% 50.0V 85C
C490	1305550030	1 PC	CE 10U0F +20% 50.0V 85C
C492	1305550030	1 PC	CE 10U0F +20% 50.0V 85C
C494	1305550030	1 PC	CE 10U0F +20% 50.0V 85C
C496	1305550030	1 PC	CE 10U0F +20% 50.0V 85C
C497	1305550030	1 PC	CE 10U0F +20% 50.0V 85C
C498	1305550030	1 PC	CE 10U0F +20% 50.0V 85C
C501	1305550030	1 PC	CE 10U0F +20% 50.0V 85C
C502	11055300	1 PC	CC 68P0F +5% -5% 50.0V NP0
C503	20269070	1 PC	CE 100U0F +20% 25.0V 85C
C504	20269080	1 PC	CE 220U0F +20% 10.0V 85C
C505	30936070	1 PC	CC 12P0F +5% -5% 50.0V NP0
C506	60439150	1 PC	CC 33P0F +5% -5% 50.0V NP0
C507	1305550030	1 PC	CE 10U0F +20% 50.0V 85C ALSO 1305550030
C508	1305550030	1 PC	CE 10U0F +20% 50.0V 85C
C509	55179360	1 PC	CPM 100N0F +10% 63.0V
C510	55179360	1 PC	CPM 100N0F +10% 63.0V
C513	11055540	1 PC	CC 2N2F +10% -10% 50.0V Y5P
C551	55179400	1 PC	CPM 68N0F +5% 63.0V
C552	55179400	1 PC	CPM 68N0F +5% 63.0V
C553	55179400	1 PC	CPM 68N0F +5% 63.0V
C554	20252670	1 PC	CE 470U0F +20% 10.0V 85C
C555	1105934091	1 PC	CC 10N0F +10% -10% 50.0V Y5P
C556	1105934091	1 PC	CC 10N0F +10% -10% 50.0V Y5P
C564	55095430	1 PC	CPM 100N0F +10% 250.0V
C565	55095430	1 PC	CPM 100N0F +10% 250.0V
C566	10364820	1 PC	CPF 47N0F +10% 100.0V
C567	10364820	1 PC	CPF 47N0F +10% 100.0V
	15002130		
C568	or 1500213041 J3471610031X J3470110031X	1 PC	CE 10U0F +20% 16.0V 85C
C569	5512607016 8043682091	or 1 PC	CC 680P0F +10% -10% 50.0V Y5P
C570	5512607016 8043682091	or 1 PC	CC 680P0F +10% -10% 50.0V Y5P
C571	5512607016 8043682091	or 1 PC	CC 680P0F +10% -10% 50.0V Y5P
C421	13076940	1 PC	CE 470U0F +20% 63.0V 85C
C422	13076940	1 PC	CE 470U0F +20% 63.0V 85C
C423	13076940	1 PC	CE 470U0F +20% 63.0V 85C
C424	13076940	1 PC	CE 470U0F +20% 63.0V 85C
C481	55134050	1 PC	CE 8MI2F +20% 63.0V 85C
C481	55329160	1 PC	CE 8MI2F +20% 63.0V 85C
C482	55134050	1 PC	CE 8MI2F +20% 63.0V 85C
C482	55329160	1 PC	CE 8MI2F +20% 63.0V 85C
C485	40433130NR	1 PC	CE 2MI2F +20% 35.0V 85C
C486	40433130NR	1 PC	CE 2MI2F +20% 35.0V 85C
C487	55126160DD	1 PC	CE 6MI8F +20% 16.0V 85C
C488	13039870	1 PC	CE 2MI2F +20% 16.0V 85C
C511	13076940	1 PC	CE 470U0F +20% 63.0V 85C
C512	13076940	1 PC	CE 470U0F +20% 63.0V 85C

Ref. Designator	Part Number	Qty	Description
<i>Semiconductors</i>			
D401	13-0482	1 PC	D-SLP 1N4148 100.0V 150E-3A
D402	13-0482	1 PC	D-SLP 1N4148 100.0V 150E-3A
D403	13-0482	1 PC	D-SLP 1N4148 100.0V 150E-3A
D404	13-0482	1 PC	D-SLP 1N4148 100.0V 150E-3A
D405	13-0482	1 PC	D-SLP 1N4148 100.0V 150E-3A
D406	13-0482	1 PC	D-SLP 1N4148 100.0V 150E-3A
D501	13-0482	1 PC	D-SLP 1N4148 100.0V 150E-3A
D502	13-0482	1 PC	D-SLP 1N4148 100.0V 150E-3A
D551	13-0482	1 PC	D-SLP 1N4148 100.0V 150E-3A
D552	13-0482	1 PC	D-SLP 1N4148 100.0V 150E-3A
D553	13-0482	1 PC	D-SLP 1N4148 100.0V 150E-3A
D554	13-0482	1 PC	D-SLP 1N4148 100.0V 150E-3A
D555	13-0482	1 PC	D-SLP 1N4148 100.0V 150E-3A
D556	13-0482	1 PC	D-SLP 1N4148 100.0V 150E-3A
D566	13-0482	1 PC	D-SLP 1N4148 100.0V 150E-3A
D567	13-0482	1 PC	D-SLP 1N4148 100.0V 150E-3A
Q401	20556600	1 PC	TR-SHPLF KTC3200BL N 100MIOA 120V
Q402	20556600	1 PC	TR-SHPLF KTC3200BL N 100MIOA 120V
Q403	20556600	1 PC	TR-SHPLF KTC3200BL N 100MIOA 120V
Q404	20556600	1 PC	TR-SHPLF KTC3200BL N 100MIOA 120V
Q405	20556600	1 PC	TR-SHPLF KTC3200BL N 100MIOA 120V
Q406	20556600	1 PC	TR-SHPLF KTC3200BL N 100MIOA 120V
Q407	TR031984100	1 PC	TR-SLPLF KTC3198BL N 150MIOA
Q408	TR031984100	1 PC	TR-SLPLF KTC3198BL N 150MIOA
Q411	20647850	1 PC	TR-SHPLF KTA1268BL P 100MIOA 120V
Q412	20647850	1 PC	TR-SHPLF KTA1268BL P 100MIOA 120V
Q413	20647850	1 PC	TR-SHPLF KTA1268BL P 100MIOA 120V
Q414	20647850	1 PC	TR-SHPLF KTA1268BL P 100MIOA 120V
Q415	20556600	1 PC	TR-SHPLF KTC3200BL N 100MIOA 120V
Q416	20556600	1 PC	TR-SHPLF KTC3200BL N 100MIOA 120V
Q417	55133260	1 PC	TR-SLPLF KTA1024 Y P 50MIOA -150V
Q418	55133260	1 PC	TR-SLPLF KTA1024 Y P 50MIOA -150V
Q419	55133240	1 PC	TR-SLPLF KTC3206 Y N 50MIOA 150V
Q420	55133240	1 PC	TR-SLPLF KTC3206 Y N 50MIOA 150V
Q421	55133260	1 PC	TR-SLPLF KTA1024 Y P 50MIOA -150V
Q422	55133260	1 PC	TR-SLPLF KTA1024 Y P 50MIOA -150V
Q423	55133240	1 PC	TR-SLPLF KTC3206 Y N 50MIOA 150V
Q424	55133240	1 PC	TR-SLPLF KTC3206 Y N 50MIOA 150V
Q427	20556600	1 PC	TR-SHPLF KTC3200BL N 100MIOA 120V
Q428	20556600	1 PC	TR-SHPLF KTC3200BL N 100MIOA 120V
Q429	55133240	1 PC	TR-SLPLF KTC3206 Y N 50MIOA 150V
Q430	55133240	1 PC	TR-SLPLF KTC3206 Y N 50MIOA 150V
Q431	55133260	1 PC	TR-SLPLF KTA1024 Y P 50MIOA -150V
Q432	55133260	1 PC	TR-SLPLF KTA1024 Y P 50MIOA -150V
Q501	20556600	1 PC	TR-SHPLF KTC3200BL N 100MIOA 120V
Q502	20556600	1 PC	TR-SHPLF KTC3200BL N 100MIOA 120V
Q503	20556600	1 PC	TR-SHPLF KTC3200BL N 100MIOA 120V
Q504	TR031984100	1 PC	TR-SLPLF KTC3198BL N 150MIOA
Q506	20647850	1 PC	TR-SHPLF KTA1268BL P 100MIOA 120V
Q507	20647850	1 PC	TR-SHPLF KTA1268BL P 100MIOA 120V
Q508	20556600	1 PC	TR-SHPLF KTC3200BL N 100MIOA 120V
Q509	55133260	1 PC	TR-SLPLF KTA1024 Y P 50MIOA -150V
Q510	55133240	1 PC	TR-SLPLF KTC3206 Y N 50MIOA 150V
Q511	55133260	1 PC	TR-SLPLF KTA1024 Y P 50MIOA -150V
Q512	55133240	1 PC	TR-SLPLF KTC3206 Y N 50MIOA 150V
Q514	20556600	1 PC	TR-SHPLF KTC3200BL N 100MIOA 120V
Q515	55133240	1 PC	TR-SLPLF KTC3206 Y N 50MIOA 150V
Q516	55133260	1 PC	TR-SLPLF KTA1024 Y P 50MIOA -150V

Ref. Designator	Part Number	Qty	Description
Q551	20556600	1 PC	TR-SHPLF KTC3200BL N 100MIOA 120V
Q552	20556600	1 PC	TR-SHPLF KTC3200BL N 100MIOA 120V
Q553	20556600	1 PC	TR-SHPLF KTC3200BL N 100MIOA 120V
Q554	20508080	1 PC	TR-SLPLF KTC3198BL N 150MIOA
Q555	20508080	1 PC	TR-SLPLF KTC3198BL N 150MIOA
Q556	20508080	1 PC	TR-SLPLF KTC3198BL N 150MIOA
Q557	20508210	1 PC	TR-SLPLF KTA1266 Y P 150MIOA
Q558	55133260	1 PC	TR-SLPLF KTA1024 Y P 50MIOA -150V
Q559	55179230	1 PC	TR-SLPSWA KRC107M N
Q561	20647850	1 PC	TR-SHPLF KTA1268BL P 100MIOA 120V
D481	55179280	1 PC	D-BRDLC BRIDGE BU8-04F FRONTIER
D482	55179300	1 PC	D-BRDLC BRIDGE W2-04F FRONTIER
D568	55125540	1 PC	D-BRDLC BU6-04F
IC101	55142240	1 PC	IC-OPERAMP NJM2068DD DUAL OP
IC481	20832440	1 PC	IC-REGPOFXD KIA7815API NORMAL
IC482	55124020	1 PC	IC-REGNEGFXD KIA7915PI NORMAL
IC483	55125450	1 PC	IC-REGPOFXD BA033T NORMAL
IC484	55123960	1 PC	IC-REGPOFXD KIA7805API NORMAL
IC485	55123960	1 PC	IC-REGPOFXD KIA7805API NORMAL
IC486	55123990	1 PC	IC-REGNEGFXD KIA7905PI NORMAL
IC487	55179240	1 PC	IC-REGULADJ KA337 TO-220
Q425	55179200	1 PC	TR-SHPLF 2SC4883A N 2.0A
Q426	55179200	1 PC	TR-SHPLF 2SC4883A N 2.0A
Q433	55179190	1 PC	TR-SHPLF 2SA1859A P -2.0A
Q434	55179190	1 PC	TR-SHPLF 2SA1859A P -2.0A
Q435	55179200	1 PC	TR-SHPLF 2SC4883A N 2.0A
Q436	55179200	1 PC	TR-SHPLF 2SC4883A N 2.0A
Q437	55179180	1 PC	TR-SHPLF 2SC5358-R N 15.0A
Q438	55179180	1 PC	TR-SHPLF 2SC5358-R N 15.0A
Q439	55179150	1 PC	TR-SHPLF 2SA1986-R P -15.0A
Q440	55179150	1 PC	TR-SHPLF 2SA1986-R P -15.0A
Q513	55179200	1 PC	TR-SHPLF 2SC4883A N 2.0A
Q517	55179190	1 PC	TR-SHPLF 2SA1859A P -2.0A
Q518	55179200	1 PC	TR-SHPLF 2SC4883A N 2.0A
Q519	55179180	1 PC	TR-SHPLF 2SC5358-R N 15.0A
Q520	55179150	1 PC	TR-SHPLF 2SA1986-R P -15.0A

Resistors

R101	30939510	1 PC	RCF 100K0 OHM +5% 250MIOW
R102	30939510	1 PC	RCF 100K0 OHM +5% 250MIOW
R103	90571120	1 PC	RCF 12K0 OHM +5% 250MIOW
R104	90571120	1 PC	RCF 12K0 OHM +5% 250MIOW
R105	11059640	1 PC	RCF 1K0 OHM +5% 250MIOW
R106	11059640	1 PC	RCF 1K0 OHM +5% 250MIOW
R107	50882950	1 PC	RCF 100R0 OHM +5% 250MIOW
R108	30939510	1 PC	RCF 100K0 OHM +5% 250MIOW
R109	30939510	1 PC	RCF 100K0 OHM +5% 250MIOW
R110	50882950	1 PC	RCF 100R0 OHM +5% 250MIOW
R111	50882970	1 PC	RCF 470R0 OHM +5% 250MIOW
R112	20469460	1 PC	RCF 2K2 OHM +5% 250MIOW
R113	30939510	1 PC	RCF 100K0 OHM +5% 250MIOW
R114	30939510	1 PC	RCF 100K0 OHM +5% 250MIOW
R115	50882970	1 PC	RCF 470R0 OHM +5% 250MIOW
R116	50882970	1 PC	RCF 470R0 OHM +5% 250MIOW
R117	30939510	1 PC	RCF 100K0 OHM +5% 250MIOW
R118	30939510	1 PC	RCF 100K0 OHM +5% 250MIOW
R119	50882970	1 PC	RCF 470R0 OHM +5% 250MIOW
R120	50882970	1 PC	RCF 470R0 OHM +5% 250MIOW
R121	50882970	1 PC	RCF 470R0 OHM +5% 250MIOW

Ref. Designator	Part Number	Qty	Description
R122	50882970	1 PC	RCF 470R0 OHM +5% 250MI0W
R123	50882970	1 PC	RCF 470R0 OHM +5% 250MI0W
R125	50882970	1 PC	RCF 470R0 OHM +5% 250MI0W
R126	50882970	1 PC	RCF 470R0 OHM +5% 250MI0W
R127	30939510	1 PC	RCF 100K0 OHM +5% 250MI0W
R128	30939510	1 PC	RCF 100K0 OHM +5% 250MI0W
R129	30939510	1 PC	RCF 100K0 OHM +5% 250MI0W
R130	50882970	1 PC	RCF 470R0 OHM +5% 250MI0W
R132	30939510	1 PC	RCF 100K0 OHM +5% 250MI0W
R401	60441550	1 PC	RCF 330R0 OHM +5% 250MI0W
R402	60441550	1 PC	RCF 330R0 OHM +5% 250MI0W
R403	30939490	1 PC	RCF 33K0 OHM +5% 250MI0W
R404	30939490	1 PC	RCF 33K0 OHM +5% 250MI0W
R405	40435630	1 PC	RCF 1K5 OHM +5% 250MI0W
R406	40435630	1 PC	RCF 1K5 OHM +5% 250MI0W
R407	40435630	1 PC	RCF 1K5 OHM +5% 250MI0W
R408	40435630	1 PC	RCF 1K5 OHM +5% 250MI0W
R409	20469450	1 PC	RCF 220R0 OHM +5% 250MI0W
R410	20469450	1 PC	RCF 220R0 OHM +5% 250MI0W
R411	20469450	1 PC	RCF 220R0 OHM +5% 250MI0W
R412	20469450	1 PC	RCF 220R0 OHM +5% 250MI0W
R413	11059610	1 PC	RCF 270R0 OHM +5% 250MI0W
R414	11059610	1 PC	RCF 270R0 OHM +5% 250MI0W
R415	20469510	1 PC	RCF 43K0 OHM +5% 250MI0W
R416	20469510	1 PC	RCF 43K0 OHM +5% 250MI0W
R417	30939490	1 PC	RCF 33K0 OHM +5% 250MI0W
R418	30939490	1 PC	RCF 33K0 OHM +5% 250MI0W
R419	11059660	1 PC	RCF 2K0 OHM +5% 250MI0W
R420	11059660	1 PC	RCF 2K0 OHM +5% 250MI0W
R421	60441560	1 PC	RCF 560R0 OHM +5% 250MI0W
R422	60441560	1 PC	RCF 560R0 OHM +5% 250MI0W
R423	60441560	1 PC	RCF 560R0 OHM +5% 250MI0W
R424	60441560	1 PC	RCF 560R0 OHM +5% 250MI0W
R425	60441560	1 PC	RCF 560R0 OHM +5% 250MI0W
R426	60441560	1 PC	RCF 560R0 OHM +5% 250MI0W
R427	60441560	1 PC	RCF 560R0 OHM +5% 250MI0W
R428	60441560	1 PC	RCF 560R0 OHM +5% 250MI0W
R429	60441560	1 PC	RCF 560R0 OHM +5% 250MI0W
R430	60441560	1 PC	RCF 560R0 OHM +5% 250MI0W
R431	60441560	1 PC	RCF 560R0 OHM +5% 250MI0W
R432	60441560	1 PC	RCF 560R0 OHM +5% 250MI0W
R433	50882960	1 PC	RCF 150R0 OHM +5% 250MI0W
R434	50882960	1 PC	RCF 150R0 OHM +5% 250MI0W
R435	50882960	1 PC	RCF 150R0 OHM +5% 250MI0W
R436	50882960	1 PC	RCF 150R0 OHM +5% 250MI0W
R437	50883010	1 PC	RCF 15K0 OHM +5% 250MI0W
R438	50883010	1 PC	RCF 15K0 OHM +5% 250MI0W
R439	50883010	1 PC	RCF 15K0 OHM +5% 250MI0W
R440	50883010	1 PC	RCF 15K0 OHM +5% 250MI0W
R441	50882960	1 PC	RCF 150R0 OHM +5% 250MI0W
R442	50882960	1 PC	RCF 150R0 OHM +5% 250MI0W
R443	50882960	1 PC	RCF 150R0 OHM +5% 250MI0W
R444	50882960	1 PC	RCF 150R0 OHM +5% 250MI0W
R445	55242290	1 PC	RMF 10R0 OHM +5% 500MI0W
R446	55242290	1 PC	RMF 10R0 OHM +5% 500MI0W
R447	55242290	1 PC	RMF 10R0 OHM +5% 500MI0W
R448	55242290	1 PC	RMF 10R0 OHM +5% 500MI0W
R449	11059640	1 PC	RCF 1K0 OHM +5% 250MI0W
R450	11059640	1 PC	RCF 1K0 OHM +5% 250MI0W
R451	60441560	1 PC	RCF 560R0 OHM +5% 250MI0W

Ref. Designator	Part Number	Qty	Description
R452	60441560	1 PC	RCF 560R0 OHM +5% 250MI0W
R453	40435640	1 PC	RCF 4K7 OHM +5% 250MI0W
R454	40435640	1 PC	RCF 4K7 OHM +5% 250MI0W
R455	70430560	1 PC	RCF 5K6 OHM +5% 250MI0W
R456	70430560	1 PC	RCF 5K6 OHM +5% 250MI0W
R457	50882950	1 PC	RCF 100R0 OHM +5% 250MI0W
R458	50882950	1 PC	RCF 100R0 OHM +5% 250MI0W
R459	50882950	1 PC	RCF 100R0 OHM +5% 250MI0W
R460	50882950	1 PC	RCF 100R0 OHM +5% 250MI0W
R461	30939370	1 PC	RCF 15R0 OHM +5% 250MI0W
R462	30939370	1 PC	RCF 15R0 OHM +5% 250MI0W
R463	30939370	1 PC	RCF 15R0 OHM +5% 250MI0W
R464	30939370	1 PC	RCF 15R0 OHM +5% 250MI0W
R465	40438910	1 PC	RCF 2R2 OHM +5% 250MI0W
R466	40438910	1 PC	RCF 2R2 OHM +5% 250MI0W
R467	40438910	1 PC	RCF 2R2 OHM +5% 250MI0W
R468	40438910	1 PC	RCF 2R2 OHM +5% 250MI0W
R469	11059590	1 PC	RCF 82R0 OHM +5% 250MI0W
R470	11059590	1 PC	RCF 82R0 OHM +5% 250MI0W
R473	55242290	1 PC	RCF 10R0 OHM +5% 250MI0W
R474	55242290	1 PC	RCF 10R0 OHM +5% 250MI0W
R477	55242290	1 PC	RCF 10R0 OHM +5% 250MI0W
R478	55242290	1 PC	RCF 10R0 OHM +5% 250MI0W
R489	20469450	1 PC	RCF 220R0 OHM +5% 250MI0W
R490	11059630	1 PC	RCF 680R0 OHM +5% 250MI0W
R501	60441550	1 PC	RCF 330R0 OHM +5% 250MI0W
R502	30939490	1 PC	RCF 33K0 OHM +5% 250MI0W
R503	40435630	1 PC	RCF 1K5 OHM +5% 250MI0W
R504	40435630	1 PC	RCF 1K5 OHM +5% 250MI0W
R505	20469450	1 PC	RCF 220R0 OHM +5% 250MI0W
R506	20469450	1 PC	RCF 220R0 OHM +5% 250MI0W
R507	11059610	1 PC	RCF 270R0 OHM +5% 250MI0W
R508	20469510	1 PC	RCF 43K0 OHM +5% 250MI0W
R509	30939490	1 PC	RCF 33K0 OHM +5% 250MI0W
R510	11059660	1 PC	RCF 2K0 OHM +5% 250MI0W
R511	60441560	1 PC	RCF 560R0 OHM +5% 250MI0W
R512	60441560	1 PC	RCF 560R0 OHM +5% 250MI0W
R513	60441560	1 PC	RCF 560R0 OHM +5% 250MI0W
R514	60441560	1 PC	RCF 560R0 OHM +5% 250MI0W
R515	60441560	1 PC	RCF 560R0 OHM +5% 250MI0W
R516	60441560	1 PC	RCF 560R0 OHM +5% 250MI0W
R517	50882960	1 PC	RCF 150R0 OHM +5% 250MI0W
R518	50882960	1 PC	RCF 150R0 OHM +5% 250MI0W
R519	50883010	1 PC	RCF 15K0 OHM +5% 250MI0W
R520	50883010	1 PC	RCF 15K0 OHM +5% 250MI0W
R521	50882960	1 PC	RCF 150R0 OHM +5% 250MI0W
R522	50882960	1 PC	RCF 150R0 OHM +5% 250MI0W
R523	55242290	1 PC	RMF 10R0 OHM +5% 500MI0W
R524	55242290	1 PC	RMF 10R0 OHM +5% 500MI0W
R525	11059640	1 PC	RCF 1K0 OHM +5% 250MI0W
R526	60441560	1 PC	RCF 560R0 OHM +5% 250MI0W
R527	40435640	1 PC	RCF 4K7 OHM +5% 250MI0W
R528	70430560	1 PC	RCF 5K6 OHM +5% 250MI0W
R529	50882950	1 PC	RCF 100R0 OHM +5% 250MI0W
R530	50882950	1 PC	RCF 100R0 OHM +5% 250MI0W
R531	30939370	1 PC	RCF 15R0 OHM +5% 250MI0W
R532	30939370	1 PC	RCF 15R0 OHM +5% 250MI0W
R533	40438910	1 PC	RCF 2R2 OHM +5% 250MI0W
R534	40438910	1 PC	RCF 2R2 OHM +5% 250MI0W
R535	11059590	1 PC	RCF 82R0 OHM +5% 250MI0W

Ref. Designator	Part Number	Qty	Description
R537	55242290	1 PC	RCF 10R0 OHM +5% 250MI0W
R539	55242290	1 PC	RCF 10R0 OHM +5% 250MI0W
R551	40435630	1 PC	RCF 1K5 OHM +5% 250MI0W
R552	40435630	1 PC	RCF 1K5 OHM +5% 250MI0W
R553	50883010	1 PC	RCF 15K0 OHM +5% 250MI0W
R554	50883010	1 PC	RCF 15K0 OHM +5% 250MI0W
R555	60441580	1 PC	RCF 22K0 OHM +5% 250MI0W
R556	60441580	1 PC	RCF 22K0 OHM +5% 250MI0W
R557	40435630	1 PC	RCF 1K5 OHM +5% 250MI0W
R558	50883010	1 PC	RCF 15K0 OHM +5% 250MI0W
R559	60441580	1 PC	RCF 22K0 OHM +5% 250MI0W
R561	70430570	1 PC	RCF 8K2 OHM +5% 250MI0W
R562	11059710	1 PC	RCF 56K0 OHM +5% 250MI0W
R563	11059710	1 PC	RCF 56K0 OHM +5% 250MI0W
R564	11059710	1 PC	RCF 56K0 OHM +5% 250MI0W
R565	50883010	1 PC	RCF 15K0 OHM +5% 250MI0W
R566	50882950	1 PC	RCF 100R0 OHM +5% 250MI0W
R567	30939480	1 PC	RCF 10K0 OHM +5% 250MI0W
R568	30939480	1 PC	RCF 10K0 OHM +5% 250MI0W
R569	30939480	1 PC	RCF 10K0 OHM +5% 250MI0W
R570	11059610	1 PC	RCF 270R0 OHM +5% 250MI0W
R571	80437030	1 PC	RCF 27K0 OHM +5% 250MI0W
R585	40435630	1 PC	RCF 1K5 OHM +5% 250MI0W
R586	40435630	1 PC	RCF 1K5 OHM +5% 250MI0W
R587	90571130	1 PC	RCF 39K0 OHM +5% 250MI0W
R588	90571130	1 PC	RCF 39K0 OHM +5% 250MI0W
R589	40435630	1 PC	RCF 1K5 OHM +5% 250MI0W
R590	90571130	1 PC	RCF 39K0 OHM +5% 250MI0W
R591	30939480	1 PC	RCF 10K0 OHM +5% 250MI0W
R592	90571130	1 PC	RCF 39K0 OHM +5% 250MI0W
R593	50882970	1 PC	RCF 470R0 OHM +5% 250MI0W
R594	50882970	1 PC	RCF 470R0 OHM +5% 250MI0W
R595	50882970	1 PC	RCF 470R0 OHM +5% 250MI0W
R471	55179340	1 PC	RW 220MI0 OHM +5% 5.0W 100PPM/C -100PPM/C
R472	55179340	1 PC	RW 220MI0 OHM +5% 5.0W 100PPM/C -100PPM/C
R475	60442550	1 PC	RMOF 10R0 OHM +5% 1.0W
R476	60442550	1 PC	RMOF 10R0 OHM +5% 1.0W
R481	15022710	1 PC	RMOF 10R0 OHM +5% 2.0W
R482	15022710	1 PC	RMOF 10R0 OHM +5% 2.0W
R483	15022710	1 PC	RMOF 10R0 OHM +5% 2.0W
R484	80442780	1 PC	RMOF 4R7 OHM +5% 2.0W
R485	80442780	1 PC	RMOF 4R7 OHM +5% 2.0W
R486	80442780	1 PC	RMOF 4R7 OHM +5% 2.0W
R487	40440550	1 PC	RMOF 3R3 OHM +5% 2.0W
R536	55179340	1 PC	RW 220MI0 OHM +5% 5.0W 100PPM/C -100PPM/C
R538	60442550	1 PC	RMOF 10R0 OHM +5% 1.0W
VR401	55152180	1 PC	PR 1K0 OHM +30% 100MI0W
VR402	55152180	1 PC	PR 1K0 OHM +30% 100MI0W
VR501	55152180	1 PC	PR 1K0 OHM +30% 100MI0W

Miscellaneous

FH401	55170330	1 PC	TERMFUSEHLDR FUSE-HOLDER J4210020001X
FH402	55170330	1 PC	TERMFUSEHLDR FUSE-HOLDER J4210020001X
FH403	55170330	1 PC	TERMFUSEHLDR FUSE-HOLDER J4210020001X
FH404	55170330	1 PC	TERMFUSEHLDR FUSE-HOLDER J4210020001X
FH405	55170330	1 PC	TERMFUSEHLDR FUSE-HOLDER J4210020001X
FH406	55170330	1 PC	TERMFUSEHLDR FUSE-HOLDER J4210020001X
FH407	55170330	1 PC	TERMFUSEHLDR FUSE-HOLDER J4210020001X
FH408	55170330	1 PC	TERMFUSEHLDR FUSE-HOLDER J4210020001X

Ref. Designator	Part Number	Qty	Description
CN401	55171550	1 PC	CON 3.96MM PITCH MOLEX 35313-0310 ALSO 55171550
CN402	55146610	1 PC	CONN 2.5MM 6 MA ST NAT 0 0
CN403	55146570	1 PC	CONN 2.5MM 3 MA ST NAT 0 0
CN407	55171520	1 PC	CONN 2.0MM 5 MA ST NAT MOLEX 35336-0510 0 0
CN408	55125010	1 PC	CONN 2.0MM 15 MA ST NAT MOLEX 35336-1510 0 0
CN409	55125010	1 PC	CONN 2.0MM 15 MA ST NAT MOLEX 35336-1510 0 0
CN410	55125010	1 PC	CONN 2.0MM 15 MA ST NAT MOLEX 35336-1510 0 0
CN411	55125010	1 PC	CONN 2.0MM 15 MA ST NAT MOLEX 35336-1510 0 0
CN412	55174630	1 PC	CONN 2.0MM 19 MA ST NAT MOLEX 35336-1910 0 0
CN413	55174620	1 PC	CONN 2.0MM 17 MA ST NAT MOLEX 35336-1710 0 0
CN414	55179440	1 PC	CONN 1.25MM 27 FE ST WH GF120-27S-TS 2794 A4
CN415	55125010	1 PC	CONN 2.0MM 15 MA ST NAT MOLEX 35336-1510 0 0
CN415	55205630	1 PC	CONN 2.0MM 16 MA ST NAT MOLEX 35336-1610 0 0
CN416	55123330	1 PC	CONN 2.0MM 6 MA ST NAT LW2002P06 0 0
CN417	55146570	1 PC	CONN 2.5MM 3 MA ST NAT 0 0
CN418	55124960	1 PC	CONN 2.0MM 11 MA ST NAT MOLEX 35336-1110 0 0
CN419	55174590	1 PC	CONN 2.0MM 9 MA ST NAT MOLEX 35336-0910 0 0
CP401	55182570	1 PC	WIRECONASY UNIQUE 7P 240MM UL1533 SHIELD 28 1
FU481	20828790	1 PC	FUSULSLWBL 2.0 A 250.0 V
FU482	20828790	1 PC	FUSULSLWBL 2.0 A 250.0 V
FU483	20828790	1 PC	FUSULSLWBL 2.0 A 250.0 V
FU484	20828790	1 PC	FUSULSLWBL 2.0 A 250.0 V
G011	55135980	1 PC	TERMLUG GND
JK404	55191420	1 PC	CON PHONO SCKT RCA 4P JW-4104RSA
JK405	55191480	1 PC	CON PHONO SCKT RCA 6P JW-4105RSB
JK407	55176330	1 PC	CON PHONO SCKT RCA 4P JW4104RS GND
JK408	55191370	1 PC	CON PHONO SCKT RCA 1P JACK JE010003XN
JK503	55191400	1 PC	CONN-SPE TERMINAL SPKR 6P SH0611705P FE 19MM 6 BK 0 0
L401	55179560	1 PC	LFA 1MM 10MM 5 LEFT
L402	55179560	1 PC	LFA 1MM 10MM 5 LEFT
L501	55179560	1 PC	LFA 1MM 10MM 5 LEFT
P551	55179640	1 PC	POS 100R0 OHM 16.0V
W101	20720260	1 PC	WCL 100-05-05 UL1007 HOOK-UP 26 100MM BK 5 5 20182780 0.0MM
W401	20720260	1 PC	WCL 100-05-05 UL1007 HOOK-UP 26 100MM BK 5 5 20182780 0.0MM
W401	55104610	1 PC	WCL M PART(250-10-10 + 2 TERMINALS) UL1007 HOOK-UP 18 250MM BK 10
W401	55244370	1 PC	WIRECONASY UNIQUE 1P 250MM UL1007 PVC DISCRETE 18 1
W402	20899230	1 PC	WCL 050-05-05 UL1007 HOOK-UP 26 50MM BK 5 5 20182780 0.0MM
WA401	55146560	1 PC	CONN 2.5MM 2 MA ST NAT 0 0
WA402	55146560	1 PC	CONN 2.5MM 2 MA ST NAT 0 0
WA403	55146560	1 PC	CONN 2.5MM 2 MA ST NAT 0 0

Input PCB

Capacitors

C101	20268880	1 PC	CE 10U0F +20% 50.0V 85C
C102	20268880	1 PC	CE 10U0F +20% 50.0V 85C
C103	20268880	1 PC	CE 10U0F +20% 50.0V 85C
C104	20268880	1 PC	CE 10U0F +20% 50.0V 85C
C105	20267830	1 PC	CE 47U0F +20% 16.0V 85C
C106	20267830	1 PC	CE 47U0F +20% 16.0V 85C
C107	20268880	1 PC	CE 10U0F +20% 50.0V 85C
C108	20268880	1 PC	CE 10U0F +20% 50.0V 85C
C109	20936650	1 PC	CC 100P0F +10% -10% 50.0V Y5P
C110	20936650	1 PC	CC 100P0F +10% -10% 50.0V Y5P
C111	20936650	1 PC	CC 100P0F +10% -10% 50.0V Y5P
C112	20268880	1 PC	CE 10U0F +20% 50.0V 85C
C113	20268880	1 PC	CE 10U0F +20% 50.0V 85C
C114	20936650	1 PC	CC 100P0F +10% -10% 50.0V Y5P
C115	20936650	1 PC	CC 100P0F +10% -10% 50.0V Y5P
C116	20936650	1 PC	CC 100P0F +10% -10% 50.0V Y5P

Ref. Designator	Part Number	Qty	Description
C117	20250040	1 PC	CC 220P0F +10% -10% 50.0V Y5P
C118	20250040	1 PC	CC 220P0F +10% -10% 50.0V Y5P
C119	20246470	1 PC	CC 100N0F +80% -20% 25.0V Z5V
C120	20250040	1 PC	CC 220P0F +10% -10% 50.0V Y5P
C121	20250040	1 PC	CC 220P0F +10% -10% 50.0V Y5P
C122	20250040	1 PC	CC 220P0F +10% -10% 50.0V Y5P
C123	20246470	1 PC	CC 100N0F +80% -20% 25.0V Z5V
C124	20250040	1 PC	CC 220P0F +10% -10% 50.0V Y5P
C125	20250040	1 PC	CC 220P0F +10% -10% 50.0V Y5P
C126	20246470	1 PC	CC 100N0F +80% -20% 25.0V Z5V
C127	20267830	1 PC	CE 47U0F +20% 16.0V 85C
C128	20267830	1 PC	CE 47U0F +20% 16.0V 85C
C129	10291350	1 PC	CC 33P0F +5% -5% 50.0V SL
C130	20268880	1 PC	CE 10U0F +20% 50.0V 85C
C131	10291350	1 PC	CC 33P0F +5% -5% 50.0V SL
C132	20268880	1 PC	CE 10U0F +20% 50.0V 85C
C133	20267830	1 PC	CE 47U0F +20% 16.0V 85C
C134	20267830	1 PC	CE 47U0F +20% 16.0V 85C
C135	20268880	1 PC	CE 10U0F +20% 50.0V 85C
C136	20268880	1 PC	CE 10U0F +20% 50.0V 85C
C137	20267830	1 PC	CE 47U0F +20% 16.0V 85C
C138	20267830	1 PC	CE 47U0F +20% 16.0V 85C

Semiconductors

IC101	55142710GR	1 PC	IC-SWITCH KIC9162AF ANALOG SWITCH
IC102	55142720KV	1 PC	IC-LOWFREQ KIC9459F SOP24 TONE/VOL/BAL/MUTE
IC103	55142610CQ	1 PC	IC-OPERAMP NJM2068M DUAL OP
IC104	55142610CQ	1 PC	IC-OPERAMP NJM2068M DUAL OP
Q101	55133220	1 PC	TR-SLPLF DTA114YSA P 100MI0A
Q101	55133350	1 PC	TR-SLPLF MPSA56 Y P -500MI0A -300V
Q102	55133290	1 PC	TR-SLPLF KTD1302 B N 300MI0A 20V
Q103	55133290	1 PC	TR-SLPLF KTD1302 B N 300MI0A 20V
Q104	55133210	1 PC	TR-SLPLF DTC114YSA N 100MI0A

Resistors

R143	80440510	1 PC	RMGCFMIN 0 OHM +0% 100MI0W
R145	80440510	1 PC	RMGCFMIN 0 OHM +0% 100MI0W
R147	80440510	1 PC	RMGCFMIN 0 OHM +0% 100MI0W
R149	80440510	1 PC	RMGCFMIN 0 OHM +0% 100MI0W
R151	80440510	1 PC	RMGCFMIN 0 OHM +0% 100MI0W
R101	50882950	1 PC	RCF 100R0 OHM +5% 250MI0W
R102	50882950	1 PC	RCF 100R0 OHM +5% 250MI0W
R103	30939510	1 PC	RCF 100K0 OHM +5% 250MI0W
R104	30939510	1 PC	RCF 100K0 OHM +5% 250MI0W
R105	30939510	1 PC	RCF 100K0 OHM +5% 250MI0W
R106	30939510	1 PC	RCF 100K0 OHM +5% 250MI0W
R107	11059640	1 PC	RCF 1K0 OHM +5% 250MI0W
R108	11059640	1 PC	RCF 1K0 OHM +5% 250MI0W
R109	11059640	1 PC	RCF 1K0 OHM +5% 250MI0W
R110	30939510	1 PC	RCF 100K0 OHM +5% 250MI0W
R111	30939510	1 PC	RCF 100K0 OHM +5% 250MI0W
R112	11059640	1 PC	RCF 1K0 OHM +5% 250MI0W
R113	11059640	1 PC	RCF 1K0 OHM +5% 250MI0W
R114	30939510	1 PC	RCF 100K0 OHM +5% 250MI0W
R115	30939510	1 PC	RCF 100K0 OHM +5% 250MI0W
R116	11059640	1 PC	RCF 1K0 OHM +5% 250MI0W
R117	11059640	1 PC	RCF 1K0 OHM +5% 250MI0W
R118	11059640	1 PC	RCF 1K0 OHM +5% 250MI0W
R119	11059640	1 PC	RCF 1K0 OHM +5% 250MI0W
R120	11059640	1 PC	RCF 1K0 OHM +5% 250MI0W
R121	50882950	1 PC	RCF 100R0 OHM +5% 250MI0W
R122	50882950	1 PC	RCF 100R0 OHM +5% 250MI0W

Ref. Designator	Part Number	Qty	Description
R123	11059690	1 PC	RCF 18K0 OHM +5% 250MIOW
R123	30939480	1 PC	RCF 10K0 OHM +5% 250MIOW
R124	11059640	1 PC	RCF 1K0 OHM +5% 250MIOW
R124	11059690	1 PC	RCF 18K0 OHM +5% 250MIOW
R125	70430560	1 PC	RCF 5K6 OHM +5% 250MIOW
R126	11059640	1 PC	RCF 1K0 OHM +5% 250MIOW
R127	30939510	1 PC	RCF 100K0 OHM +5% 250MIOW
R128	50882970	1 PC	RCF 470R0 OHM +5% 250MIOW
R129	70430560	1 PC	RCF 5K6 OHM +5% 250MIOW
R130	11059640	1 PC	RCF 1K0 OHM +5% 250MIOW
R131	30939510	1 PC	RCF 100K0 OHM +5% 250MIOW
R132	50882970	1 PC	RCF 470R0 OHM +5% 250MIOW
R133	50882950	1 PC	RCF 100R0 OHM +5% 250MIOW
R134	50882950	1 PC	RCF 100R0 OHM +5% 250MIOW
R135	30939510	1 PC	RCF 100K0 OHM +5% 250MIOW
R136	30939510	1 PC	RCF 100K0 OHM +5% 250MIOW
R137	50882950	1 PC	RCF 100R0 OHM +5% 250MIOW
R138	50882950	1 PC	RCF 100R0 OHM +5% 250MIOW
R139	50882950	1 PC	RCF 100R0 OHM +5% 250MIOW
R140	50882950	1 PC	RCF 100R0 OHM +5% 250MIOW
R141	11059780	1 PC	RCF 1M0 OHM +5% 250MIOW
R142	60441600	1 PC	RCF 68K0 OHM +5% 250MIOW

Miscellaneous

CN101	55199410	1 PC	WIRECONASY UNIQUE 14P 520MM UL1533 SHIELD 28 1
CN102	55175920	1 PC	WIRECONASY UNIQUE 10P 520MM UL1533 SHIELD 28 1
CN103	55175910	1 PC	WIRECONASY UNIQUE 12P 390MM UL1533 SHIELD 26 1
CN103	55221860	1 PC	WIRECONASY UNIQUE 12P 290MM UL1533 SHIELD 28 1
CP101	55174640	1 PC	CONN 2.0MM 9 MA R NAT SOCKET MOLEX 35237-0910 0 0
CP102	55125030	1 PC	CONN 2.0MM 11 MA R NAT MOLEX 35237-1110 0 0
JK101	55175970	1 PC	CON PHONO SCKT RCA 2P JC0200098N
JK101	55207740	1 PC	CON PHONO SCKT RCA 2P JE021163TN BRN/TAN
JK102	55191410	1 PC	CON PHONO SCKT RCA 4P JW-4104RSB
JK102	55195480	1 PC	CON PHONO SCKT RCA 2P JACK JE021163MN GY,GN
JK103	55191800	1 PC	CON PHONO SCKT RCA 6P JW4105RSG W/GNDCAP WH,RD,BU,WH,RD,BU
JK103	55195490	1 PC	CON PHONO SCKT RCA 3P JACK JE031164TN WH,RD,BU

Surround PCB

Capacitors

C350	20252050	1 PC	CE 100U0F +20% 6.3V 85C
C351	20252050	1 PC	CE 100U0F +20% 6.3V 85C
C352	20268880	1 PC	CE 10U0F +20% 50.0V 85C
C353	20268880	1 PC	CE 10U0F +20% 50.0V 85C
C354	20268880	1 PC	CE 10U0F +20% 50.0V 85C
C355	20268840	1 PC	CE 1U0F +20% 50.0V 85C
C360	20268840	1 PC	CE 1U0F +20% 50.0V 85C
C361	20252050	1 PC	CE 100U0F +20% 6.3V 85C
C362	20246470	1 PC	CC 100N0F +80% -20% 25.0V Z5V
C363	20246470	1 PC	CC 100N0F +80% -20% 25.0V Z5V
C364	20246470	1 PC	CC 100N0F +80% -20% 25.0V Z5V
C365	20936650	1 PC	CC 100P0F +10% -10% 50.0V Y5P
C366	20246470	1 PC	CC 100N0F +80% -20% 25.0V Z5V
C367	20246470	1 PC	CC 100N0F +80% -20% 25.0V Z5V
C368	20246470	1 PC	CC 100N0F +80% -20% 25.0V Z5V
C369	20246470	1 PC	CC 100N0F +80% -20% 25.0V Z5V
C370	20936650	1 PC	CC 100P0F +10% -10% 50.0V Y5P
C371	20936650	1 PC	CC 100P0F +10% -10% 50.0V Y5P
C372	20267830	1 PC	CE 47U0F +20% 16.0V 85C
C373	20267830	1 PC	CE 47U0F +20% 16.0V 85C
C374	20267830	1 PC	CE 47U0F +20% 16.0V 85C

Ref. Designator	Part Number	Qty	Description
C375	20267830	1 PC	CE 47U0F +20% 16.0V 85C
C386	20246470	1 PC	CC 100N0F +80% -20% 25.0V Z5V
C601	20268880	1 PC	CE 10U0F +20% 50.0V 85C
C602	20268880	1 PC	CE 10U0F +20% 50.0V 85C
C603	11055300	1 PC	CC 68P0F +5% -5% 50.0V NP0
C604	11055300	1 PC	CC 68P0F +5% -5% 50.0V NP0
C605	20269070	1 PC	CE 100U0F +20% 25.0V 85C
C606	20269070	1 PC	CE 100U0F +20% 25.0V 85C
C607	20269080	1 PC	CE 220U0F +20% 10.0V 85C
C608	20269080	1 PC	CE 220U0F +20% 10.0V 85C
C609	30936070	1 PC	CC 12P0F +5% -5% 50.0V NP0
C610	30936070	1 PC	CC 12P0F +5% -5% 50.0V NP0
C611	60439150	1 PC	CC 33P0F +5% -5% 50.0V NP0
C612	60439150	1 PC	CC 33P0F +5% -5% 50.0V NP0
C613	20268880	1 PC	CE 10U0F +20% 50.0V 85C
C614	20268880	1 PC	CE 10U0F +20% 50.0V 85C
C615	20268880	1 PC	CE 10U0F +20% 50.0V 85C
C616	20268880	1 PC	CE 10U0F +20% 50.0V 85C
C617	55179360	1 PC	CPM 100N0F +10% 63.0V
C618	55179360	1 PC	CPM 100N0F +10% 63.0V
C619	55179360	1 PC	CPM 100N0F +10% 63.0V
C620	55179360	1 PC	CPM 100N0F +10% 63.0V
C625	11055560	1 PC	CC 3N3F +10% -10% 50.0V Y5P
C626	11055560	1 PC	CC 3N3F +10% -10% 50.0V Y5P
C629	40433580	1 PC	CC 680P0F +10% -10% 50.0V Y5P
C630	40433580	1 PC	CC 680P0F +10% -10% 50.0V Y5P
C681	55179400	1 PC	CPM 68N0F +5% 63.0V
C682	55179400	1 PC	CPM 68N0F +5% 63.0V
C693	55095430	1 PC	CPM 100N0F +10% 250.0V
C694	55095430	1 PC	CPM 100N0F +10% 250.0V
C695	55095430	1 PC	CPM 100N0F +10% 250.0V
C696	15002130	1 PC	CE 10U0F +20% 16.0V 85C
C971	20268840	1 PC	CE 1U0F +20% 50.0V 85C
C983	70428520	1 PC	CC 10N0F +10% -10% 50.0V Y5P
C985	20495030	1 PC	CC 100N0F +10% -10% 25.0V Y5P
C986	20268840	1 PC	CE 1U0F +20% 50.0V 85C
C987	20268880	1 PC	CE 10U0F +20% 50.0V 85C
C988	20495030	1 PC	CC 100N0F +10% -10% 25.0V Y5P
C991	20269010	1 PC	CE 47U0F +20% 50.0V 85C
C992	13039350	1 PC	CE 100U0F +20% 35.0V 85C
C993	20495030	1 PC	CC 100N0F +10% -10% 25.0V Y5P
C994	20495030	1 PC	CC 100N0F +10% -10% 25.0V Y5P
C995	20495030	1 PC	CC 100N0F +10% -10% 25.0V Y5P
C997	70428520	1 PC	CC 10N0F +10% -10% 50.0V Y5P
C998	70428520	1 PC	CC 10N0F +10% -10% 50.0V Y5P
C999	70428520	1 PC	CC 10N0F +10% -10% 50.0V Y5P
C378	15041100	1 PC	RA 3M3 OHM +10% 500MI0W
C621	13073530	1 PC	CE 470U0F +20% 50.0V 85C
C622	13073530	1 PC	CE 470U0F +20% 50.0V 85C
C623	13076940	1 PC	CE 470U0F +20% 63.0V 85C
C624	13076940	1 PC	CE 470U0F +20% 63.0V 85C
C691	55199430	1 PC	CE 6MI8F +20% 50.0V 85C
C692	55199430	1 PC	CE 6MI8F +20% 50.0V 85C
C982	55095470	1 PC	CC 4N7F +20% -20% 250.0V Y5V
C984	13073530	1 PC	CE 470U0F +20% 50.0V 85C
C989	13073530	1 PC	CE 470U0F +20% 50.0V 85C
C990	13073530	1 PC	CE 470U0F +20% 50.0V 85C
CA81	55095460	1 PC	CPPMX 100N0F +20% -20%

Semiconductors

D601	70436540	1 PC	D-SLP 1N4148 100.0V 150E-3A
D602	70436540	1 PC	D-SLP 1N4148 100.0V 150E-3A
D603	70436540	1 PC	D-SLP 1N4148 100.0V 150E-3A

Ref. Designator	Part Number	Qty	Description
D604	70436540	1 PC	D-SLP 1N4148 100.0V 150E-3A
D681	70436540	1 PC	D-SLP 1N4148 100.0V 150E-3A
D682	70436540	1 PC	D-SLP 1N4148 100.0V 150E-3A
D683	70436540	1 PC	D-SLP 1N4148 100.0V 150E-3A
D684	70436540	1 PC	D-SLP 1N4148 100.0V 150E-3A
D685	70436540	1 PC	D-SLP 1N4148 100.0V 150E-3A
D987	70436540	1 PC	D-SLP 1N4148 100.0V 150E-3A
D988	70436540	1 PC	D-SLP 1N4148 100.0V 150E-3A
D991	20475340	1 PC	D-ZENER BZX55B30 30V 500MI0W
D992	70436540	1 PC	D-SLP 1N4148 100.0V 150E-3A
D994	20873880	1 PC	D-ZENER 1N5236B 7.5V 500MI0W
D996	20526960	1 PC	D-ZENER 1N5231B 5.1V 500MI0W
Q301	55133210	1 PC	TR-SLPLF DTC114YSA N 100MI0A
Q601	20556600	1 PC	TR-SHPLF KTC3200BL N 100MI0A 120V
Q602	20556600	1 PC	TR-SHPLF KTC3200BL N 100MI0A 120V
Q603	20556600	1 PC	TR-SHPLF KTC3200BL N 100MI0A 120V
Q604	20556600	1 PC	TR-SHPLF KTC3200BL N 100MI0A 120V
Q605	20556600	1 PC	TR-SHPLF KTC3200BL N 100MI0A 120V
Q606	20556600	1 PC	TR-SHPLF KTC3200BL N 100MI0A 120V
Q607	20508080	1 PC	TR-SLPLF KTC3198BL N 150MI0A
Q608	20508080	1 PC	TR-SLPLF KTC3198BL N 150MI0A
Q611	20647850	1 PC	TR-SHPLF KTA1268BL P 100MI0A 120V
Q612	20647850	1 PC	TR-SHPLF KTA1268BL P 100MI0A 120V
Q613	20647850	1 PC	TR-SHPLF KTA1268BL P 100MI0A 120V
Q614	20647850	1 PC	TR-SHPLF KTA1268BL P 100MI0A 120V
Q615	20556600	1 PC	TR-SHPLF KTC3200BL N 100MI0A 120V
Q616	20556600	1 PC	TR-SHPLF KTC3200BL N 100MI0A 120V
Q617	55133260	1 PC	TR-SLPLF KTA1024 Y P 50MI0A -150V
Q618	55133260	1 PC	TR-SLPLF KTA1024 Y P 50MI0A -150V
Q619	55133240	1 PC	TR-SLPLF KTC3206 Y N 50MI0A 150V
Q620	55133240	1 PC	TR-SLPLF KTC3206 Y N 50MI0A 150V
Q621	55133260	1 PC	TR-SLPLF KTA1024 Y P 50MI0A -150V
Q622	55133260	1 PC	TR-SLPLF KTA1024 Y P 50MI0A -150V
Q623	55133240	1 PC	TR-SLPLF KTC3206 Y N 50MI0A 150V
Q624	55133240	1 PC	TR-SLPLF KTC3206 Y N 50MI0A 150V
Q627	20556600	1 PC	TR-SHPLF KTC3200BL N 100MI0A 120V
Q628	20556600	1 PC	TR-SHPLF KTC3200BL N 100MI0A 120V
Q629	55133240	1 PC	TR-SLPLF KTC3206 Y N 50MI0A 150V
Q630	55133240	1 PC	TR-SLPLF KTC3206 Y N 50MI0A 150V
Q631	55133260	1 PC	TR-SLPLF KTA1024 Y P 50MI0A -150V
Q632	55133260	1 PC	TR-SLPLF KTA1024 Y P 50MI0A -150V
Q681	20556600	1 PC	TR-SHPLF KTC3200BL N 100MI0A 120V
Q682	20556600	1 PC	TR-SHPLF KTC3200BL N 100MI0A 120V
Q683	20647850	1 PC	TR-SHPLF KTA1268BL P 100MI0A 120V
Q981	20647850	1 PC	TR-SHPLF KTA1268BL P 100MI0A 120V
Q982	55142670	1 PC	TR-SLPLF MPSA06 N 500MI0A
D691	55125540	1 PC	D-BRDLC BU6-04F
D981	20415060	1 PC	D-SR 1N4004 400.0V 1.0A
D982	20415060	1 PC	D-SR 1N4004 400.0V 1.0A
D983	20415060	1 PC	D-SR 1N4004 400.0V 1.0A
D984	20415060	1 PC	D-SR 1N4004 400.0V 1.0A
D985	20415060	1 PC	D-SR 1N4004 400.0V 1.0A
D986	20415060	1 PC	D-SR 1N4004 400.0V 1.0A
D989	20415060	1 PC	D-SR 1N4004 400.0V 1.0A
D990	20415060	1 PC	D-SR 1N4004 400.0V 1.0A
IC390	5517960085	1 PC	IC-LOGIC TC4053BFN SOL16 MULTIPLEXER CMOS
IC391	55175530KV	1 PC	IC-VIDEOPROC TSH95D VIDEO AMPLIFIER
IC981	55179250	1 PC	IC-REGPOFXD KIA7805API TO-220IS NORMAL
Q625	55179200	1 PC	TR-SHPLF 2SC4883A N 2.0A
Q626	55179200	1 PC	TR-SHPLF 2SC4883A N 2.0A
Q633	55179190	1 PC	TR-SHPLF 2SA1859A P -2.0A
Q634	55179190	1 PC	TR-SHPLF 2SA1859A P -2.0A
Q635	55179200	1 PC	TR-SHPLF 2SC4883A N 2.0A
Q636	55179200	1 PC	TR-SHPLF 2SC4883A N 2.0A

Ref. Designator	Part Number	Qty	Description
Q637	55179180	1 PC	TR-SHPLF 2SC5358-R N 15.0A
Q638	55179180	1 PC	TR-SHPLF 2SC5358-R N 15.0A
Q639	55179150	1 PC	TR-SHPLF 2SA1986-R P -15.0A
Q640	55179150	1 PC	TR-SHPLF 2SA1986-R P -15.0A

Resistors

R350	70430520	1 PC	RCF 75R0 OHM +5% 250MI0W
R351	70430520	1 PC	RCF 75R0 OHM +5% 250MI0W
R352	60441580	1 PC	RCF 22K0 OHM +5% 250MI0W
R353	70430520	1 PC	RCF 75R0 OHM +5% 250MI0W
R354	70430520	1 PC	RCF 75R0 OHM +5% 250MI0W
R355	30939360	1 PC	RCF 10R0 OHM +5% 250MI0W
R356	70430520	1 PC	RCF 75R0 OHM +5% 250MI0W
R357	70430520	1 PC	RCF 75R0 OHM +5% 250MI0W
R358	30939360	1 PC	RCF 10R0 OHM +5% 250MI0W
R359	70430520	1 PC	RCF 75R0 OHM +5% 250MI0W
R360	30939360	1 PC	RCF 10R0 OHM +5% 250MI0W
R361	60441560	1 PC	RCF 560R0 OHM +5% 250MI0W
R362	80436970	1 PC	RCF 510R0 OHM +5% 250MI0W
R363	30939480	1 PC	RCF 10K0 OHM +5% 250MI0W
R364	60441560	1 PC	RCF 560R0 OHM +5% 250MI0W
R365	80436970	1 PC	RCF 510R0 OHM +5% 250MI0W
R366	30939480	1 PC	RCF 10K0 OHM +5% 250MI0W
R367	60441560	1 PC	RCF 560R0 OHM +5% 250MI0W
R368	80436970	1 PC	RCF 510R0 OHM +5% 250MI0W
R369	30939480	1 PC	RCF 10K0 OHM +5% 250MI0W
R370	70430520	1 PC	RCF 75R0 OHM +5% 250MI0W
R371	60441580	1 PC	RCF 22K0 OHM +5% 250MI0W
R372	70430520	1 PC	RCF 75R0 OHM +5% 250MI0W
R373	60441580	1 PC	RCF 22K0 OHM +5% 250MI0W
R374	30939480	1 PC	RCF 10K0 OHM +5% 250MI0W
R601	60441550	1 PC	RCF 330R0 OHM +5% 250MI0W
R602	60441550	1 PC	RCF 330R0 OHM +5% 250MI0W
R603	30939490	1 PC	RCF 33K0 OHM +5% 250MI0W
R604	30939490	1 PC	RCF 33K0 OHM +5% 250MI0W
R605	40435630	1 PC	RCF 1K5 OHM +5% 250MI0W
R606	40435630	1 PC	RCF 1K5 OHM +5% 250MI0W
R607	40435630	1 PC	RCF 1K5 OHM +5% 250MI0W
R608	40435630	1 PC	RCF 1K5 OHM +5% 250MI0W
R609	20469450	1 PC	RCF 220R0 OHM +5% 250MI0W
R610	20469450	1 PC	RCF 220R0 OHM +5% 250MI0W
R611	20469450	1 PC	RCF 220R0 OHM +5% 250MI0W
R612	20469450	1 PC	RCF 220R0 OHM +5% 250MI0W
R613	11059610	1 PC	RCF 270R0 OHM +5% 250MI0W
R614	11059610	1 PC	RCF 270R0 OHM +5% 250MI0W
R615	20469510	1 PC	RCF 43K0 OHM +5% 250MI0W
R616	20469510	1 PC	RCF 43K0 OHM +5% 250MI0W
R617	30939490	1 PC	RCF 33K0 OHM +5% 250MI0W
R618	30939490	1 PC	RCF 33K0 OHM +5% 250MI0W
R619	11059660	1 PC	RCF 2K0 OHM +5% 250MI0W
R620	11059660	1 PC	RCF 2K0 OHM +5% 250MI0W
R621	60441560	1 PC	RCF 560R0 OHM +5% 250MI0W
R622	60441560	1 PC	RCF 560R0 OHM +5% 250MI0W
R623	60441560	1 PC	RCF 560R0 OHM +5% 250MI0W
R624	60441560	1 PC	RCF 560R0 OHM +5% 250MI0W
R625	60441560	1 PC	RCF 560R0 OHM +5% 250MI0W
R626	60441560	1 PC	RCF 560R0 OHM +5% 250MI0W
R627	60441560	1 PC	RCF 560R0 OHM +5% 250MI0W
R628	60441560	1 PC	RCF 560R0 OHM +5% 250MI0W
R629	60441560	1 PC	RCF 560R0 OHM +5% 250MI0W
R630	60441560	1 PC	RCF 560R0 OHM +5% 250MI0W
R631	60441560	1 PC	RCF 560R0 OHM +5% 250MI0W
R632	60441560	1 PC	RCF 560R0 OHM +5% 250MI0W

Ref. Designator	Part Number	Qty	Description
R633	50882960	1 PC	RCF 150R0 OHM +5% 250MI0W
R634	50882960	1 PC	RCF 150R0 OHM +5% 250MI0W
R635	50882960	1 PC	RCF 150R0 OHM +5% 250MI0W
R636	50882960	1 PC	RCF 150R0 OHM +5% 250MI0W
R637	50883010	1 PC	RCF 15K0 OHM +5% 250MI0W
R638	50883010	1 PC	RCF 15K0 OHM +5% 250MI0W
R639	50883010	1 PC	RCF 15K0 OHM +5% 250MI0W
R640	50883010	1 PC	RCF 15K0 OHM +5% 250MI0W
R641	50882960	1 PC	RCF 150R0 OHM +5% 250MI0W
R642	50882960	1 PC	RCF 150R0 OHM +5% 250MI0W
R643	50882960	1 PC	RCF 150R0 OHM +5% 250MI0W
R644	50882960	1 PC	RCF 150R0 OHM +5% 250MI0W
R645	30939360	1 PC	RCF 10R0 OHM +5% 250MI0W
R645	55232810	1 PC	RMF 10R0 OHM +5% 500MI0W
R645	55242290	1 PC	RCF 10R0 OHM +5% 250MI0W
R646	30939360	1 PC	RCF 10R0 OHM +5% 250MI0W
R646	55232810	1 PC	RMF 10R0 OHM +5% 500MI0W
R646	55242290	1 PC	RCF 10R0 OHM +5% 250MI0W
R647	30939360	1 PC	RCF 10R0 OHM +5% 250MI0W
R647	55232810	1 PC	RMF 10R0 OHM +5% 500MI0W
R647	55242290	1 PC	RCF 10R0 OHM +5% 250MI0W
R648	30939360	1 PC	RCF 10R0 OHM +5% 250MI0W
R648	55232810	1 PC	RMF 10R0 OHM +5% 500MI0W
R648	55242290	1 PC	RCF 10R0 OHM +5% 250MI0W
R649	11059640	1 PC	RCF 1K0 OHM +5% 250MI0W
R650	11059640	1 PC	RCF 1K0 OHM +5% 250MI0W
R651	60441560	1 PC	RCF 560R0 OHM +5% 250MI0W
R652	60441560	1 PC	RCF 560R0 OHM +5% 250MI0W
R653	40435640	1 PC	RCF 4K7 OHM +5% 250MI0W
R654	40435640	1 PC	RCF 4K7 OHM +5% 250MI0W
R655	70430560	1 PC	RCF 5K6 OHM +5% 250MI0W
R656	70430560	1 PC	RCF 5K6 OHM +5% 250MI0W
R657	50882950	1 PC	RCF 100R0 OHM +5% 250MI0W
R658	50882950	1 PC	RCF 100R0 OHM +5% 250MI0W
R659	50882950	1 PC	RCF 100R0 OHM +5% 250MI0W
R660	50882950	1 PC	RCF 100R0 OHM +5% 250MI0W
R661	30939370	1 PC	RCF 15R0 OHM +5% 250MI0W
R662	30939370	1 PC	RCF 15R0 OHM +5% 250MI0W
R663	30939370	1 PC	RCF 15R0 OHM +5% 250MI0W
R664	30939370	1 PC	RCF 15R0 OHM +5% 250MI0W
R665	40438910	1 PC	RCF 2R2 OHM +5% 250MI0W
R666	40438910	1 PC	RCF 2R2 OHM +5% 250MI0W
R667	40438910	1 PC	RCF 2R2 OHM +5% 250MI0W
R668	40438910	1 PC	RCF 2R2 OHM +5% 250MI0W
R669	11059590	1 PC	RCF 82R0 OHM +5% 250MI0W
R670	11059590	1 PC	RCF 82R0 OHM +5% 250MI0W
R673	30939360	1 PC	RCF 10R0 OHM +5% 250MI0W
R674	30939360	1 PC	RCF 10R0 OHM +5% 250MI0W
R677	30939360	1 PC	RCF 10R0 OHM +5% 250MI0W
R678	30939360	1 PC	RCF 10R0 OHM +5% 250MI0W
R679	50882970	1 PC	RCF 470R0 OHM +5% 250MI0W
R680	50882970	1 PC	RCF 470R0 OHM +5% 250MI0W
R681	40435630	1 PC	RCF 1K5 OHM +5% 250MI0W
R682	40435630	1 PC	RCF 1K5 OHM +5% 250MI0W
R683	50883010	1 PC	RCF 15K0 OHM +5% 250MI0W
R684	50883010	1 PC	RCF 15K0 OHM +5% 250MI0W
R685	60441580	1 PC	RCF 22K0 OHM +5% 250MI0W
R686	60441580	1 PC	RCF 22K0 OHM +5% 250MI0W
R687	40435630	1 PC	RCF 1K5 OHM +5% 250MI0W
R688	40435630	1 PC	RCF 1K5 OHM +5% 250MI0W
R689	90571130	1 PC	RCF 39K0 OHM +5% 250MI0W
R690	90571130	1 PC	RCF 39K0 OHM +5% 250MI0W
R691	30939480	1 PC	RCF 10K0 OHM +5% 250MI0W
R692	90571130	1 PC	RCF 39K0 OHM +5% 250MI0W

Ref. Designator	Part Number	Qty	Description
R971	30939480	1 PC	RCF 10K0 OHM +5% 250MI0W
R972	30939510	1 PC	RCF 100K0 OHM +5% 250MI0W
R981	20472530	1 PC	RCF 4R7 OHM +5% 250MI0W
R982	20469460	1 PC	RCF 2K2 OHM +5% 250MI0W
R983	11059640	1 PC	RCF 1K0 OHM +5% 250MI0W
R984	11059670	1 PC	RCF 2K7 OHM +5% 250MI0W
R985	30939380	1 PC	RCF 22R0 OHM +5% 250MI0W
R986	20469460	1 PC	RCF 2K2 OHM +5% 250MI0W
R987	60441560	1 PC	RCF 560R0 OHM +5% 250MI0W
R988	11067570	1 PC	RCF 1R0 OHM +5% 250MI0W
R989	11067570	1 PC	RCF 1R0 OHM +5% 250MI0W
R993	70430560	1 PC	RCF 5K6 OHM +5% 250MI0W
R671	55179340	1 PC	RW 220MI0 OHM +5% 5.0W 100PPM/C -100PPM/C
R672	55179340	1 PC	RW 220MI0 OHM +5% 5.0W 100PPM/C -100PPM/C
R675	60442550	1 PC	RMOF 10R0 OHM +5% 1.0W
R676	60442550	1 PC	RMOF 10R0 OHM +5% 1.0W
R995	55180100	1 PC	RA 3M3 OHM +10% 500MI0W
<i>Miscellaneous</i>			
FH981	55170330	1 PC	TERMFUSEHLDR FUSE-HOLDER J4210020001X
FH982	55170330	1 PC	TERMFUSEHLDR FUSE-HOLDER J4210020001X
	50	55176410	1 PC AC HEATSINK 17*15*30 AVR520 -- ME
	55	55127070	1 PC SCREW-ST 3MM 10MM JIS B 1122 19 0 0
AC981	55206550	1 PC	CONN-SPE AC OUTLET 2P 110V FE 12.75MM 2 BK 0 0
BKT1	55176420	1 PC	AC PUN BRACKET BKT GROUND ET 0.5T AVR520 --
BKT2	55176420	1 PC	AC PUN BRACKET BKT GROUND ET 0.5T AVR520 --
CN390	55123310	1 PC	CONN 2.0MM 4 MA ST NAT LW2002P04 0 0
CN391	55090080	1 PC	CONN 2.0MM 3 MA ST NAT LW2002P03 0 0
CN606	55191230	1 PC	WIRECONASY UNIQUE 3P 864MM UL1007 PVC DISCRETE 26 1
FU981	55170820	1 PC	FUSULSLWBL 6.3 A 125.0 V
H012	55180170	1 PC	WIRECONASY UNIQUE 1P 200MM UL1007 PVC DISCRETE 18 1
H020	55180170	1 PC	WIRECONASY UNIQUE 1P 200MM UL1007 PVC DISCRETE 18 1
JA290	55176360	1 PC	CON PHONO SCKT RCA 9P W/GND CAP JK090122LN
JK601	55191390	1 PC	CONN-SPE TERMINAL SPKR 4P SH0410376P FE 19MM 4 BK 0 0
L601	55179560	1 PC	LFA 1MM 10MM 5 LEFT
L602	55179560	1 PC	LFA 1MM 10MM 5 LEFT
RL981	55091500	1 PC	RELAYPWR 12.0V 270.0OHM 10.0A 250.0V
T981	55175760	1 PC	TF-LAM 110V STANDBY 120V
VR601	55152180	1 PC	PR 1K0 OHM +30% 100MI0W
VR602	55152180	1 PC	PR 1K0 OHM +30% 100MI0W
WA601	55171550	1 PC	CONN 2.5MM 2 MA ST NAT 0 0 E934
WA602	55171550	1 PC	CONN 2.5MM 2 MA ST NAT 0 0
WA603	55171550	1 PC	CON 3.96MM PITCH MOLEX 35313-0310
WA625	55123310	1 PC	CONN 2.0MM 4 MA ST NAT LW2002P04 0 0
WA981	5504884A	1 PC	CON 3.96MM PITCH HEADER 2 POS
WA983	55123510	1 PC	CON 3.96MM PITCH HEADER 2 POS MOLEX 35328-0210
WA985	55123510	1 PC	CON 3.96MM PITCH HEADER 2 POS MOLEX 35328-0210
WA986	55146620	1 PC	CONN 2.5MM 7 MA ST NAT 0 0

Front PCB

Capacitors

C205	20267290	1 PC	CCCFMIN 100N0F +80% -20% 50.0V Y5V
C206	50882360	1 PC	CCCFMIN 33P0F +5% -5% 50.0V NP0
C208	50882360	1 PC	CCCFMIN 33P0F +5% -5% 50.0V NP0
C209	20267290	1 PC	CCCFMIN 100N0F +80% -20% 50.0V Y5V
C211	15070900	1 PC	CCCFMIN 820P0F +10% -10% 50.0V NP0
C212	15070900	1 PC	CCCFMIN 820P0F +10% -10% 50.0V NP0
C213	20267290	1 PC	CCCFMIN 100N0F +80% -20% 50.0V Y5V
C217	20267290	1 PC	CCCFMIN 100N0F +80% -20% 50.0V Y5V
C218	20267290	1 PC	CCCFMIN 100N0F +80% -20% 50.0V Y5V
C228	11058670	1 PC	CCCFMIN 100P0F +5% -5% 50.0V NP0

Ref. Designator	Part Number	Qty	Description
C229	11058670	1 PC	CCCFMIN 100P0F +5% -5% 50.0V NP0
C230	11058670	1 PC	CCCFMIN 100P0F +5% -5% 50.0V NP0
C237	20267290	1 PC	CCCFMIN 100N0F +80% -20% 50.0V Y5V
C238	20267290	1 PC	CCCFMIN 100N0F +80% -20% 50.0V Y5V
C239	20267290	1 PC	CCCFMIN 100N0F +80% -20% 50.0V Y5V
C240	20267290	1 PC	CCCFMIN 100N0F +80% -20% 50.0V Y5V
C241	20267290	1 PC	CCCFMIN 100N0F +80% -20% 50.0V Y5V
C242	20267290	1 PC	CCCFMIN 100N0F +80% -20% 50.0V Y5V
C244	20267290	1 PC	CCCFMIN 100N0F +80% -20% 50.0V Y5V
C245	20267290	1 PC	CCCFMIN 100N0F +80% -20% 50.0V Y5V
C246	11058670	1 PC	CCCFMIN 100P0F +5% -5% 50.0V NP0
C247	11058670	1 PC	CCCFMIN 100P0F +5% -5% 50.0V NP0
C248	11058670	1 PC	CCCFMIN 100P0F +5% -5% 50.0V NP0
CL211	11058670	1 PC	CCCFMIN 100P0F +5% -5% 50.0V NP0
CR211	11058670	1 PC	CCCFMIN 100P0F +5% -5% 50.0V NP0
C201	20267830	1 PC	CE 47U0F +20% 16.0V 85C
C202	20267830	1 PC	CE 47U0F +20% 16.0V 85C
C203	20267830	1 PC	CE 47U0F +20% 16.0V 85C
C204	20269010	1 PC	CE 47U0F +20% 50.0V 85C
C210	20268880	1 PC	CE 10U0F +20% 50.0V 85C
C214	20267830	1 PC	CE 47U0F +20% 16.0V 85C
C215	20267830	1 PC	CE 47U0F +20% 16.0V 85C
C219	20269010	1 PC	CE 47U0F +20% 50.0V 85C
C220	20268880	1 PC	CE 10U0F +20% 50.0V 85C
C232	20267830	1 PC	CE 47U0F +20% 16.0V 85C
C233	20267830	1 PC	CE 47U0F +20% 16.0V 85C
C234	20268950	1 PC	CE 100N0F +20% 50.0V 85C
C235	10364820	1 PC	CPF 47N0F +10% 100.0V
C236	10364820	1 PC	CPF 47N0F +10% 100.0V
CL201	1500213041	1 PC	CE 10U0F +20% 16.0V 85C
CL202	30936230	1 PC	CC 100P0F +5% -5% 50.0V NP0
CL203	80434590F	1 PC	CC 22P0F +5% -5% 50.0V NP0
CL204	15002130	1 PC	CE 10U0F +20% 16.0V 85C
CL205	15002130	1 PC	CE 10U0F +20% 16.0V 85C
CL206	55179370	1 PC	CPM 18N0F +5% 100.0V
CL207	55179410	1 PC	CPM 82N0F +5% 100.0V
CL208	55179390	1 PC	CPM 3N3F +5% 100.0V
CL209	55179370	1 PC	CPM 18N0F +5% 100.0V
CR201	15002130	1 PC	CE 10U0F +20% 16.0V 85C
CR202	30936230	1 PC	CC 100P0F +5% -5% 50.0V NP0
CR203	80434590	1 PC	CC 22P0F +5% -5% 50.0V NP0
CR204	15002130	1 PC	CE 10U0F +20% 16.0V 85C
CR205	15002130	1 PC	CE 10U0F +20% 16.0V 85C
CR206	55179370	1 PC	CPM 18N0F +5% 100.0V
CR207	55179410	1 PC	CPM 82N0F +5% 100.0V
CR208	55179390	1 PC	CPM 3N3F +5% 100.0V
CR209	55179370	1 PC	CPM 18N0F +5% 100.0V
C203	20267830	1 PC	CE 47U0F +20% 16.0V 85C
C210	20268880	1 PC	CE 10U0F +20% 50.0V 85C
C216	55134360	1 PC	CM 47MI0F +80% -20% 5.5V 70C

Semiconductors

D248	2049651091	1 PC	D-SLP 1SS355 35.0V 225MI0A ALSO 2049651085
D249	20496510	1 PC	D-SLP 1SS355 35.0V 225MI0A
D250	20496510	1 PC	D-SLP 1SS355 35.0V 225MI0A
D251	20496510	1 PC	D-SLP 1SS355 35.0V 225MI0A
D253	20496510	1 PC	D-SLP 1SS355 35.0V 225MI0A
D254	20496510	1 PC	D-SLP 1SS355 35.0V 225MI0A
D255	20496510	1 PC	D-SLP 1SS355 35.0V 225MI0A
D261	20496510	1 PC	D-SLP 1SS355 35.0V 225MI0A
D262	20496510	1 PC	D-SLP 1SS355 35.0V 225MI0A
D263	80440510	1 PC	RMGCFMIN 0 OHM +0% 100MI0W
D264	80440510	1 PC	RMGCFMIN 0 OHM +0% 100MI0W

Ref. Designator	Part Number	Qty	Description
IC202	2071866065	1 PC	IC-LOGIC BU4094BF SHIFT REGISTER CMOS
IC203	20718660	1 PC	IC-LOGIC BU4094BF SHIFT REGISTER CMOS
IC204	20718660	1 PC	IC-LOGIC BU4094BF SHIFT REGISTER CMOS
Q201	55133330	1 PC	TR-SSD DTC114TKA N 10K0 OHM
Q202	55133330	1 PC	TR-SSD DTC114TKA N 10K0 OHM
Q203	55133330	1 PC	TR-SSD DTC114TKA N 10K0 OHM
Q204	55133330	1 PC	TR-SSD DTC114TKA N 10K0 OHM
Q205	55133330	1 PC	TR-SSD DTC114TKA N 10K0 OHM
Q206	55133330	1 PC	TR-SSD DTC114TKA N 10K0 OHM
Q207	55133330	1 PC	TR-SSD DTC114TKA N 10K0 OHM
Q208	55133330	1 PC	TR-SSD DTC114TKA N 10K0 OHM
Q209	55133330	1 PC	TR-SSD DTC114TKA N 10K0 OHM
Q210	55133330	1 PC	TR-SSD DTC114TKA N 10K0 OHM
Q211	55133330	1 PC	TR-SSD DTC114TKA N 10K0 OHM
Q212	55133330	1 PC	TR-SSD DTC114TKA N 10K0 OHM
Q213	55133330	1 PC	TR-SSD DTC114TKA N 10K0 OHM
Q214	55133330	1 PC	TR-SSD DTC114TKA N 10K0 OHM
Q215	55133330	1 PC	TR-SSD DTC114TKA N 10K0 OHM
Q216	55133330	1 PC	TR-SSD DTC114TKA N 10K0 OHM
Q217	55133330	1 PC	TR-SSD DTC114TKA N 10K0 OHM
Q218	55133330	1 PC	TR-SSD DTC114TKA N 10K0 OHM
Q219	55133330	1 PC	TR-SSD DTC114TKA N 10K0 OHM
Q220	55133330	1 PC	TR-SSD DTC114TKA N 10K0 OHM
Q221	55133330	1 PC	TR-SSD DTC114TKA N 10K0 OHM
Q231	55133180	1 PC	TR-SSD DTC114YKA N 10K0 OHM 47K0 OHM
Q232	55133180	1 PC	TR-SSD DTC114YKA N 10K0 OHM 47K0 OHM
Q234	55133180	1 PC	TR-SSD DTC114YKA N 10K0 OHM 47K0 OHM
Q236	55133190	1 PC	TR-SSD DTA114YKA P 10K0 OHM 47K0 OHM
Q237	55133180	1 PC	TR-SSD DTC114YKA N 10K0 OHM 47K0 OHM
Q239	55133330	1 PC	TR-SSD DTC114TKA N 10K0 OHM
Q240	55133330	1 PC	TR-SSD DTC114TKA N 10K0 OHM
Q243	55133190	1 PC	TR-SSD DTA114YKA P 10K0 OHM 47K0 OHM
Q244	55133180	1 PC	TR-SSD DTC114YKA N 10K0 OHM 47K0 OHM
Q222	55133210	1 PC	TR-SLPLF DTC114YSA N 100MIOA
Q223	55133210	1 PC	TR-SLPLF DTC114YSA N 100MIOA
Q224	55133210	1 PC	TR-SLPLF DTC114YSA N 100MIOA
Q225	55133210	1 PC	TR-SLPLF DTC114YSA N 100MIOA
Q226	55133210	1 PC	TR-SLPLF DTC114YSA N 100MIOA
Q227	55142670	1 PC	TR-SLPLF MPSA06 N 500MIOA
Q233	55133350	1 PC	TR-SLPLF MPSA56 Y P -500MIOA -300V
Q235	55133210	1 PC	TR-SLPLF DTC114YSA N 100MIOA
Q241	55133290	1 PC	TR-SLPLF KTD1302 B N 300MIOA 20V
Q242	55133290	1 PC	TR-SLPLF KTD1302 B N 300MIOA 20V
	50 70436540	1 PC	D-SLP 1N4148 100.0V 150E-3A
D201	55199400	1 PC	D-LEM CT-3SGTA GN RND 3.0 CL 60M0CD
D202	55199400	1 PC	D-LEM CT-3SGTA GN RND 3.0 CL 60M0CD
D203	55199400	1 PC	D-LEM CT-3SGTA GN RND 3.0 CL 60M0CD
D204	55199400	1 PC	D-LEM CT-3SGTA GN RND 3.0 CL 60M0CD
D205	55199400	1 PC	D-LEM CT-3SGTA GN RND 3.0 CL 60M0CD
D206	55199400	1 PC	D-LEM CT-3SGTA GN RND 3.0 CL 60M0CD
D207	55199400	1 PC	D-LEM CT-3SGTA GN RND 3.0 CL 60M0CD
D208	55199400	1 PC	D-LEM CT-3SGTA GN RND 3.0 CL 60M0CD
D209	55199400	1 PC	D-LEM CT-3SGTA GN RND 3.0 CL 60M0CD
D210	55199400	1 PC	D-LEM CT-3SGTA GN RND 3.0 CL 60M0CD
D211	55199400	1 PC	D-LEM CT-3SGTA GN RND 3.0 CL 60M0CD
D212	55199400	1 PC	D-LEM CT-3SGTA GN RND 3.0 CL 60M0CD
D213	55199400	1 PC	D-LEM CT-3SGTA GN RND 3.0 CL 60M0CD
D214	55199400	1 PC	D-LEM CT-3SGTA GN RND 3.0 CL 60M0CD
D215	55199400	1 PC	D-LEM CT-3SGTA GN RND 3.0 CL 60M0CD
D216	55199400	1 PC	D-LEM CT-3SGTA GN RND 3.0 CL 60M0CD
D217	55199400	1 PC	D-LEM CT-3SGTA GN RND 3.0 CL 60M0CD
D218	55199400	1 PC	D-LEM CT-3SGTA GN RND 3.0 CL 60M0CD
D219	55199400	1 PC	D-LEM CT-3SGTA GN RND 3.0 CL 60M0CD
D220	55199400	1 PC	D-LEM CT-3SGTA GN RND 3.0 CL 60M0CD

Ref. Designator	Part Number	Qty	Description
D221	55199400	1 PC	D-LEM CT-3SGTA GN RND 3.0 CL 60M0CD
D222	55199400	1 PC	D-LEM CT-3SGTA GN RND 3.0 CL 60M0CD
D223	55199400	1 PC	D-LEM CT-3SGTA GN RND 3.0 CL 60M0CD
D224	55199400	1 PC	D-LEM CT-3SGTA GN RND 3.0 CL 60M0CD
D225	55199400	1 PC	D-LEM CT-3SGTA GN RND 3.0 CL 60M0CD
D226	55199400	1 PC	D-LEM CT-3SGTA GN RND 3.0 CL 60M0CD
D227	55199400	1 PC	D-LEM CT-3SGTA GN RND 3.0 CL 60M0CD
D228	55199400	1 PC	D-LEM CT-3SGTA GN RND 3.0 CL 60M0CD
D229	55199400	1 PC	D-LEM CT-3SGTA GN RND 3.0 CL 60M0CD
D230	55199400	1 PC	D-LEM CT-3SGTA GN RND 3.0 CL 60M0CD
D231	55199400	1 PC	D-LEM CT-3SGTA GN RND 3.0 CL 60M0CD
D232	55199400	1 PC	D-LEM CT-3SGTA GN RND 3.0 CL 60M0CD
D233	55199400	1 PC	D-LEM CT-3SGTA GN RND 3.0 CL 60M0CD
D234	55199400	1 PC	D-LEM CT-3SGTA GN RND 3.0 CL 60M0CD
D235	55199400	1 PC	D-LEM CT-3SGTA GN RND 3.0 CL 60M0CD
D236	55199400	1 PC	D-LEM CT-3SGTA GN RND 3.0 CL 60M0CD
D237	55199400	1 PC	D-LEM CT-3SGTA GN RND 3.0 CL 60M0CD
D238	55199400	1 PC	D-LEM CT-3SGTA GN RND 3.0 CL 60M0CD
D239	55199400	1 PC	D-LEM CT-3SGTA GN RND 3.0 CL 60M0CD
D240	55199400	1 PC	D-LEM CT-3SGTA GN RND 3.0 CL 60M0CD
D241	55199400	1 PC	D-LEM CT-3SGTA GN RND 3.0 CL 60M0CD
D242	55199400	1 PC	D-LEM CT-3SGTA GN RND 3.0 CL 60M0CD
D243	55199400	1 PC	D-LEM CT-3SGTA GN RND 3.0 CL 60M0CD
D244	55199400	1 PC	D-LEM CT-3SGTA GN RND 3.0 CL 60M0CD
D245	55199400	1 PC	D-LEM CT-3SGTA GN RND 3.0 CL 60M0CD
D246	55199400	1 PC	D-LEM CT-3SGTA GN RND 3.0 CL 60M0CD
D247	55199400	1 PC	D-LEM CT-3SGTA GN RND 3.0 CL 60M0CD
D257	55179310	1 PC	D-LEM RED/GREEN 3PIE RD RND CL
D258	55199400	1 PC	D-LEM CT-3SGTA GN RND 3.0 CL 60M0CD
D259	55199400	1 PC	D-LEM CT-3SGTA GN RND 3.0 CL 60M0CD
D260	55199400	1 PC	D-LEM CT-3SGTA GN RND 3.0 CL 60M0CD
D265	55199400	1 PC	D-LEM CT-3SGTA GN RND 3.0 CL 60M0CD
D266	55199400	1 PC	D-LEM CT-3SGTA GN RND 3.0 CL 60M0CD
D267	55199400	1 PC	D-LEM CT-3SGTA GN RND 3.0 CL 60M0CD
D268	55199400	1 PC	D-LEM CT-3SGTA GN RND 3.0 CL 60M0CD
IC201	5518246CMS	1 PC	IC-MICROCONT CXP82860-XXXQ MAIN AVR520
IC205	55142240	1 PC	IC-OPERAMP NJM2068DD DUAL OP

Resistors

R201	80440370	1 PC	RMGCFMIN 150R0 OHM +5% 100M10W
R202	80440370	1 PC	RMGCFMIN 150R0 OHM +5% 100M10W
R203	80440370	1 PC	RMGCFMIN 150R0 OHM +5% 100M10W
R204	80440370	1 PC	RMGCFMIN 150R0 OHM +5% 100M10W
R205	50886610	1 PC	RMGCFMIN 10K0 OHM +5% 100M10W
R205	80440370	1 PC	RMGCFMIN 150R0 OHM +5% 100M10W
R206	60444350	1 PC	RMGCFMIN 47R0 OHM +5% 100M10W
R206	80440370	1 PC	RMGCFMIN 150R0 OHM +5% 100M10W
R207	60444350	1 PC	RMGCFMIN 47R0 OHM +5% 100M10W
R207	80440370	1 PC	RMGCFMIN 150R0 OHM +5% 100M10W
R208	60444350	1 PC	RMGCFMIN 47R0 OHM +5% 100M10W
R208	80440370	1 PC	RMGCFMIN 150R0 OHM +5% 100M10W
R209	60444350	1 PC	RMGCFMIN 47R0 OHM +5% 100M10W
R209	80440370	1 PC	RMGCFMIN 150R0 OHM +5% 100M10W
R210	80440370	1 PC	RMGCFMIN 150R0 OHM +5% 100M10W
R211	60444350	1 PC	RMGCFMIN 47R0 OHM +5% 100M10W
R211	80440370	1 PC	RMGCFMIN 150R0 OHM +5% 100M10W
R212	80440370	1 PC	RMGCFMIN 150R0 OHM +5% 100M10W
R213	60444350	1 PC	RMGCFMIN 47R0 OHM +5% 100M10W
R213	80440370	1 PC	RMGCFMIN 150R0 OHM +5% 100M10W
R214	80440370	1 PC	RMGCFMIN 150R0 OHM +5% 100M10W
R215	80440370	1 PC	RMGCFMIN 150R0 OHM +5% 100M10W
R216	60444350	1 PC	RMGCFMIN 47R0 OHM +5% 100M10W
R216	80440370	1 PC	RMGCFMIN 150R0 OHM +5% 100M10W

Ref. Designator	Part Number	Qty	Description
R217	80440370	1 PC	RMGCFMIN 150R0 OHM +5% 100MIOW
R218	60444350	1 PC	RMGCFMIN 47R0 OHM +5% 100MIOW
R218	80440370	1 PC	RMGCFMIN 150R0 OHM +5% 100MIOW
R219	80440370	1 PC	RMGCFMIN 150R0 OHM +5% 100MIOW
R220	60444350	1 PC	RMGCFMIN 47R0 OHM +5% 100MIOW
R220	80440370	1 PC	RMGCFMIN 150R0 OHM +5% 100MIOW
R221	80440370	1 PC	RMGCFMIN 150R0 OHM +5% 100MIOW
R222	60444350	1 PC	RMGCFMIN 47R0 OHM +5% 100MIOW
R222	80440370	1 PC	RMGCFMIN 150R0 OHM +5% 100MIOW
R223	80440370	1 PC	RMGCFMIN 150R0 OHM +5% 100MIOW
R224	60444350	1 PC	RMGCFMIN 47R0 OHM +5% 100MIOW
R224	80440370	1 PC	RMGCFMIN 150R0 OHM +5% 100MIOW
R225	80440370	1 PC	RMGCFMIN 150R0 OHM +5% 100MIOW
R226	60444350	1 PC	RMGCFMIN 47R0 OHM +5% 100MIOW
R226	80440370	1 PC	RMGCFMIN 150R0 OHM +5% 100MIOW
R227	80440370	1 PC	RMGCFMIN 150R0 OHM +5% 100MIOW
R228	80440370	1 PC	RMGCFMIN 150R0 OHM +5% 100MIOW
R229	80440370	1 PC	RMGCFMIN 150R0 OHM +5% 100MIOW
R230	80440370	1 PC	RMGCFMIN 150R0 OHM +5% 100MIOW
R231	80440370	1 PC	RMGCFMIN 150R0 OHM +5% 100MIOW
R232	80440370	1 PC	RMGCFMIN 150R0 OHM +5% 100MIOW
R233	80440370	1 PC	RMGCFMIN 150R0 OHM +5% 100MIOW
R234	80440370	1 PC	RMGCFMIN 150R0 OHM +5% 100MIOW
R235	80440370	1 PC	RMGCFMIN 150R0 OHM +5% 100MIOW
R236	80440370	1 PC	RMGCFMIN 150R0 OHM +5% 100MIOW
R237	80440370	1 PC	RMGCFMIN 150R0 OHM +5% 100MIOW
R238	80440370	1 PC	RMGCFMIN 150R0 OHM +5% 100MIOW
R239	80440370	1 PC	RMGCFMIN 150R0 OHM +5% 100MIOW
R240	80440370	1 PC	RMGCFMIN 150R0 OHM +5% 100MIOW
R241	80440370	1 PC	RMGCFMIN 150R0 OHM +5% 100MIOW
R242	80440370	1 PC	RMGCFMIN 150R0 OHM +5% 100MIOW
R243	80440370	1 PC	RMGCFMIN 150R0 OHM +5% 100MIOW
R244	80440370	1 PC	RMGCFMIN 150R0 OHM +5% 100MIOW
R245	80440370	1 PC	RMGCFMIN 150R0 OHM +5% 100MIOW
R246	80440370	1 PC	RMGCFMIN 150R0 OHM +5% 100MIOW
R247	80440370	1 PC	RMGCFMIN 150R0 OHM +5% 100MIOW
R249	20471950	1 PC	RMGCFMIN 1K0 OHM +5% 100MIOW
R250	20471950	1 PC	RMGCFMIN 1K0 OHM +5% 100MIOW
R251	20471950	1 PC	RMGCFMIN 1K0 OHM +5% 100MIOW
R252	70434200	1 PC	RMGCFMIN 100R0 OHM +5% 100MIOW
R253	20471950	1 PC	RMGCFMIN 1K0 OHM +5% 100MIOW
R254	20471950	1 PC	RMGCFMIN 1K0 OHM +5% 100MIOW
R255	20471950	1 PC	RMGCFMIN 1K0 OHM +5% 100MIOW
R256	20471950	1 PC	RMGCFMIN 1K0 OHM +5% 100MIOW
R257	70434200	1 PC	RMGCFMIN 100R0 OHM +5% 100MIOW
R258	20471950	1 PC	RMGCFMIN 1K0 OHM +5% 100MIOW
R259	20471950	1 PC	RMGCFMIN 1K0 OHM +5% 100MIOW
R260	20471950	1 PC	RMGCFMIN 1K0 OHM +5% 100MIOW
R261	20471950	1 PC	RMGCFMIN 1K0 OHM +5% 100MIOW
R264	70434200	1 PC	RMGCFMIN 100R0 OHM +5% 100MIOW
R265	20471950	1 PC	RMGCFMIN 1K0 OHM +5% 100MIOW
R266	30944310	1 PC	RMGCFMIN 4K7 OHM +5% 100MIOW
R267	30944310	1 PC	RMGCFMIN 4K7 OHM +5% 100MIOW
R268	30944310	1 PC	RMGCFMIN 4K7 OHM +5% 100MIOW
R269	30944310	1 PC	RMGCFMIN 4K7 OHM +5% 100MIOW
R270	30944310	1 PC	RMGCFMIN 4K7 OHM +5% 100MIOW
R274	20471950	1 PC	RMGCFMIN 1K0 OHM +5% 100MIOW
R275	20471950	1 PC	RMGCFMIN 1K0 OHM +5% 100MIOW
R276	70434200	1 PC	RMGCFMIN 100R0 OHM +5% 100MIOW
R277	10355190	1 PC	RMGCFMIN 2R2 OHM +5% 100MIOW
R278	10355190	1 PC	RMGCFMIN 2R2 OHM +5% 100MIOW
R279	50886610	1 PC	RMGCFMIN 10K0 OHM +5% 100MIOW
R280	50886610	1 PC	RMGCFMIN 10K0 OHM +5% 100MIOW
R281	50886610	1 PC	RMGCFMIN 10K0 OHM +5% 100MIOW

Ref. Designator	Part Number	Qty	Description
R283	50886610	1 PC	RMGCFMIN 10K0 OHM +5% 100MIOW
R284	20471950	1 PC	RMGCFMIN 1K0 OHM +5% 100MIOW
R285	20471950	1 PC	RMGCFMIN 1K0 OHM +5% 100MIOW
R286	50886610	1 PC	RMGCFMIN 10K0 OHM +5% 100MIOW
R287	11066500	1 PC	RMGCFMIN 68K0 OHM +5% 100MIOW
R288	11066500	1 PC	RMGCFMIN 68K0 OHM +5% 100MIOW
R289	11066480	1 PC	RMGCFMIN 47K0 OHM +5% 100MIOW
R290	30944310	1 PC	RMGCFMIN 4K7 OHM +5% 100MIOW
R291	70434200	1 PC	RMGCFMIN 100R0 OHM +5% 100MIOW
R292	50886630	1 PC	RMGCFMIN 100K0 OHM +5% 100MIOW
R293	11066460	1 PC	RMGCFMIN 8K2 OHM +5% 100MIOW
R294	50886610	1 PC	RMGCFMIN 10K0 OHM +5% 100MIOW
R295	20471950	1 PC	RMGCFMIN 1K0 OHM +5% 100MIOW
R296	20471950	1 PC	RMGCFMIN 1K0 OHM +5% 100MIOW
R297	20471950	1 PC	RMGCFMIN 1K0 OHM +5% 100MIOW
R298	80440370	1 PC	RMGCFMIN 150R0 OHM +5% 100MIOW
R299	60444350	1 PC	RMGCFMIN 47R0 OHM +5% 100MIOW
R299	80440370	1 PC	RMGCFMIN 150R0 OHM +5% 100MIOW
R300	60444350	1 PC	RMGCFMIN 47R0 OHM +5% 100MIOW
R300	80440370	1 PC	RMGCFMIN 150R0 OHM +5% 100MIOW
R301	80440370	1 PC	RMGCFMIN 150R0 OHM +5% 100MIOW
R356	90574400	1 PC	RMGCFMIN 470R0 OHM +5% 100MIOW
R357	90574400	1 PC	RMGCFMIN 470R0 OHM +5% 100MIOW
R358	11066420	1 PC	RMGCFMIN 390R0 OHM +5% 100MIOW
R359	11066420	1 PC	RMGCFMIN 390R0 OHM +5% 100MIOW
R360	80440370	1 PC	RMGCFMIN 150R0 OHM +5% 100MIOW
R361	20471920	1 PC	RMGCFMIN 220R0 OHM +5% 100MIOW
R362	20471920	1 PC	RMGCFMIN 220R0 OHM +5% 100MIOW
R363	20471920	1 PC	RMGCFMIN 220R0 OHM +5% 100MIOW
R364	20471950	1 PC	RMGCFMIN 1K0 OHM +5% 100MIOW
R365	60444350	1 PC	RMGCFMIN 47R0 OHM +5% 100MIOW
R365	80440370	1 PC	RMGCFMIN 150R0 OHM +5% 100MIOW
R366	20471950	1 PC	RMGCFMIN 1K0 OHM +5% 100MIOW
R367	80440370	1 PC	RMGCFMIN 150R0 OHM +5% 100MIOW
RL201	20471950	1 PC	RMGCFMIN 1K0 OHM +5% 100MIOW
RL202	50886630	1 PC	RMGCFMIN 100K0 OHM +5% 100MIOW
RL203	50886670	1 PC	RMGCFMIN 1M0 OHM +5% 100MIOW
RL204	11066480	1 PC	RMGCFMIN 47K0 OHM +5% 100MIOW
RL205	90574400	1 PC	RMGCFMIN 470R0 OHM +5% 100MIOW
RL206	50886630	1 PC	RMGCFMIN 100K0 OHM +5% 100MIOW
RL207	20471940	1 PC	RMGCFMIN 680R0 OHM +5% 100MIOW
RL208	60444390	1 PC	RMGCFMIN 3K9 OHM +5% 100MIOW
RL209	60444400	1 PC	RMGCFMIN 22K0 OHM +5% 100MIOW
RL210	80440390	1 PC	RMGCFMIN 2K2 OHM +5% 100MIOW
RP381	50886630	1 PC	RMGCFMIN 100K0 OHM +5% 100MIOW
RP382	50886630	1 PC	RMGCFMIN 100K0 OHM +5% 100MIOW
RP383	50886630	1 PC	RMGCFMIN 100K0 OHM +5% 100MIOW
RP384	50886630	1 PC	RMGCFMIN 100K0 OHM +5% 100MIOW
RP385	50886630	1 PC	RMGCFMIN 100K0 OHM +5% 100MIOW
RP386	50886630	1 PC	RMGCFMIN 100K0 OHM +5% 100MIOW
RP387	50886630	1 PC	RMGCFMIN 100K0 OHM +5% 100MIOW
RP388	50886630	1 PC	RMGCFMIN 100K0 OHM +5% 100MIOW
RP389	50886630	1 PC	RMGCFMIN 100K0 OHM +5% 100MIOW
RP390	50886630	1 PC	RMGCFMIN 100K0 OHM +5% 100MIOW
RP391	50886630	1 PC	RMGCFMIN 100K0 OHM +5% 100MIOW
RP392	50886630	1 PC	RMGCFMIN 100K0 OHM +5% 100MIOW
RP393	50886630	1 PC	RMGCFMIN 100K0 OHM +5% 100MIOW
RP394	50886630	1 PC	RMGCFMIN 100K0 OHM +5% 100MIOW
RP395	50886630	1 PC	RMGCFMIN 100K0 OHM +5% 100MIOW
RP396	50886630	1 PC	RMGCFMIN 100K0 OHM +5% 100MIOW
RP397	50886630	1 PC	RMGCFMIN 100K0 OHM +5% 100MIOW
RP398	50886630	1 PC	RMGCFMIN 100K0 OHM +5% 100MIOW
RR201	20471950	1 PC	RMGCFMIN 1K0 OHM +5% 100MIOW
RR202	50886630	1 PC	RMGCFMIN 100K0 OHM +5% 100MIOW

Ref. Designator	Part Number	Qty	Description
RR203	50886670	1 PC	RMGCFMIN 1M0 OHM +5% 100MIOW
RR204	11066480	1 PC	RMGCFMIN 47K0 OHM +5% 100MIOW
RR205	90574400	1 PC	RMGCFMIN 470R0 OHM +5% 100MIOW
RR206	50886630	1 PC	RMGCFMIN 100K0 OHM +5% 100MIOW
RR207	20471940	1 PC	RMGCFMIN 680R0 OHM +5% 100MIOW
RR208	60444390	1 PC	RMGCFMIN 3K9 OHM +5% 100MIOW
RR209	60444400	1 PC	RMGCFMIN 22K0 OHM +5% 100MIOW
RR210	80440390	1 PC	RMGCFMIN 2K2 OHM +5% 100MIOW
R201	11059640	1 PC	RCF 1K0 OHM +5% 250MIOW
R202	11059640	1 PC	RCF 1K0 OHM +5% 250MIOW
VR201	55134900	1 PC	SWIROT EC16B24204A5 5V 500U0A 10T 3P 0 0
VR202	55179920	1 PC	PR-ROT 100K0 OHM NON-LINEAR RK14K12400BR 0 0
VR203	55179920	1 PC	PR-ROT 100K0 OHM NON-LINEAR RK14K12400BR 0 0
VR204	55179910	1 PC	PR-ROT 100K0 OHM NON-LINEAR RK14K12400BQ 0 0

Miscellaneous

J173	80440510	1 PC	RMGCFMIN 0 OHM +0% 100MIOW
J204	80440510	1 PC	RMGCFMIN 0 OHM +0% 100MIOW
J206	80440510	1 PC	RMGCFMIN 0 OHM +0% 100MIOW
J207	80440510	1 PC	RMGCFMIN 0 OHM +0% 100MIOW
J210	80440510	1 PC	RMGCFMIN 0 OHM +0% 100MIOW
J211	80440510	1 PC	RMGCFMIN 0 OHM +0% 100MIOW
J212	80440510	1 PC	RMGCFMIN 0 OHM +0% 100MIOW
J213	80440510	1 PC	RMGCFMIN 0 OHM +0% 100MIOW
J214	80440510	1 PC	RMGCFMIN 0 OHM +0% 100MIOW
J215	80440510	1 PC	RMGCFMIN 0 OHM +0% 100MIOW
J216	80440510	1 PC	RMGCFMIN 0 OHM +0% 100MIOW
J217	80440510	1 PC	RMGCFMIN 0 OHM +0% 100MIOW
J222	80440510	1 PC	RMGCFMIN 0 OHM +0% 100MIOW
J231	80440510	1 PC	RMGCFMIN 0 OHM +0% 100MIOW
J232	80440510	1 PC	RMGCFMIN 0 OHM +0% 100MIOW
J238	80440510	1 PC	RMGCFMIN 0 OHM +0% 100MIOW
J239	80440510	1 PC	RMGCFMIN 0 OHM +0% 100MIOW
J243	80440510	1 PC	RMGCFMIN 0 OHM +0% 100MIOW
J244	80440510	1 PC	RMGCFMIN 0 OHM +0% 100MIOW
J245	80440510	1 PC	RMGCFMIN 0 OHM +0% 100MIOW
J246	80440510	1 PC	RMGCFMIN 0 OHM +0% 100MIOW
J247	80440510	1 PC	RMGCFMIN 0 OHM +0% 100MIOW
J248	80440510	1 PC	RMGCFMIN 0 OHM +0% 100MIOW
J288	80440510	1 PC	RMGCFMIN 0 OHM +0% 100MIOW
J294	80440510	1 PC	RMGCFMIN 0 OHM +0% 100MIOW
J297	80440510	1 PC	RMGCFMIN 0 OHM +0% 100MIOW
J298	80440510	1 PC	RMGCFMIN 0 OHM +0% 100MIOW
CN201	5517577A	1 PC	WIRECONASY UNIQUE 7P 450MM UL1007 PVC DISCRETE 24 1
CN202	5517578A	1 PC	WIRECONASY UNIQUE 3P 620MM UL1007 PVC DISCRETE 24 1
CN203	55175810	1 PC	WIRECONASY UNIQUE 9P 400MM UL1007 PVC DISCRETE 26 1
CN204	55175790	1 PC	WIRECONASY UNIQUE 4P 100MM UL1007 PVC DISCRETE 26 1
CN205	55175840	1 PC	WIRECONASY UNIQUE 4P 360MM UL1533 SHIELD 28 1
CN206	55175830	1 PC	WIRECONASY UNIQUE 10P 220MM UL1533 SHIELD 28 1
CN208	55179520	1 PC	FFC-JUMPER 27X 1.25MM 500MM
CN209	55175850	1 PC	WIRECONASY UNIQUE 8P 500MM UL1533 SHIELD 28 1
CN210	55175880	1 PC	WIRECONASY UNIQUE 2P 100MM UL1007 PVC DISCRETE 26 1
CN211	55182560	1 PC	WIRECONASY UNIQUE 5P 300MM UL1007 PVC DISCRETE 26 1
CP201	55179450	1 PC	CONN 1.25MM 27 FE R WH GF120-27S-LS 2794 A6
CP203	55123340	1 PC	CONN 2.0MM 8 MA ST NAT LW2002P08 0 0
CP204	55123320	1 PC	CONN 2.0MM 5 MA ST NAT LW2002P05 0 0
FL201	55182450	1 PC	DISPLAY VFD HNA-16LL18
FN201	55177570	1 PC	AC PUN SHIELD FENCE TONE
J299	20441240	1 PC	BCL 0.5MM TIN ANNEALED COPPER 7.5MM 8MM FIG 1 20322610
JA201	55113740	1 PC	CON PHONO SCKT RCA-307 3 PINS
JA202	55113960	1 PC	CON DIN SCKT SOCKET CONNECTOR SVHS EST-S408J
L201	55179380	1 PC	LF 4U7H +10% 1.7 OHM 190.0A
L202	55179380	1 PC	LF 4U7H +10% 1.7 OHM 190.0A

Ref. Designator	Part Number	Qty	Description
RM201	55155930	1 PC	IC-REMOTE RPM6938-RSIP-A3 RECEIVER 38KHZ
W201	55180140	1 PC	WIRECONASY UNIQUE 1P 200MM UL1007 PVC DISCRETE 18 1
X201	55179650	1 PC	CRESONATOR 10M0 HZ 25.0 OHM 0F

Key PCB

Capacitors

C401	30939240	1 PC	CCCFMIN 22N0F +10% -10% 50.0V X7R
C402	30939240	1 PC	CCCFMIN 22N0F +10% -10% 50.0V X7R
C403	11059330	1 PC	CCCFMIN 2N2F +10% -10% 50.0V X7R
C404	11059330	1 PC	CCCFMIN 2N2F +10% -10% 50.0V X7R
C405	20267290	1 PC	CCCFMIN 100N0F +80% -20% 50.0V Y5V
C406	20267290	1 PC	CCCFMIN 100N0F +80% -20% 50.0V Y5V
C416	20267290	1 PC	CCCFMIN 100N0F +80% -20% 50.0V Y5V
C417	20267290	1 PC	CCCFMIN 100N0F +80% -20% 50.0V Y5V
C418	20267290	1 PC	CCCFMIN 100N0F +80% -20% 50.0V Y5V

Semiconductors

D402	20496510	1 PC	D-SLP 1SS355 35.0V 225MI0A
D403	20496510	1 PC	D-SLP 1SS355 35.0V 225MI0A
D404	20496510	1 PC	D-SLP 1SS355 35.0V 225MI0A
D405	20496510	1 PC	D-SLP 1SS355 35.0V 225MI0A
D406	20496510	1 PC	D-SLP 1SS355 35.0V 225MI0A
Q401	55133180	1 PC	TR-SSD DTC114YKA N 10K0 OHM 47K0 OHM
IC701	55142750	1 PC	IC-SWITCH TC9273N-007 DIP28 ANALOG SWITCH
IC702	55142750	1 PC	IC-SWITCH TC9273N-007 DIP28 ANALOG SWITCH
Q403	55179220	1 PC	TR-SLPSWA KRA107M P
IC401	55179630	1 PC	PHOTCOUP PC-17T1 PHOTOCOUPLER DIP4
IC402	55179630	1 PC	PHOTCOUP PC-17T1 PHOTOCOUPLER DIP4
Q402	55179220	1 PC	TR-SLPSWA KRA107M P
D401	55179330	1 PC	D-LEM RED/GREEN 5 RD RND CL

Resistors

R401	50886610	1 PC	RMGCFMIN 10K0 OHM +5% 100MI0W
R402	20471950	1 PC	RMGCFMIN 1K0 OHM +5% 100MI0W
R403	70434230	1 PC	RMGCFMIN 1K2 OHM +5% 100MI0W
R404	40438290	1 PC	RMGCFMIN 1K5 OHM +5% 100MI0W
R405	80440390	1 PC	RMGCFMIN 2K2 OHM +5% 100MI0W
R406	50886590	1 PC	RMGCFMIN 2K7 OHM +5% 100MI0W
R407	11066440	1 PC	RMGCFMIN 3K3 OHM +5% 100MI0W
R408	80440400	1 PC	RMGCFMIN 5K6 OHM +5% 100MI0W
R409	11066460	1 PC	RMGCFMIN 8K2 OHM +5% 100MI0W
R410	90574430	1 PC	RMGCFMIN 18K0 OHM +5% 100MI0W
R411	50886610	1 PC	RMGCFMIN 10K0 OHM +5% 100MI0W
R412	20471950	1 PC	RMGCFMIN 1K0 OHM +5% 100MI0W
R413	70434230	1 PC	RMGCFMIN 1K2 OHM +5% 100MI0W
R414	40438290	1 PC	RMGCFMIN 1K5 OHM +5% 100MI0W
R415	80440390	1 PC	RMGCFMIN 2K2 OHM +5% 100MI0W
R416	50886590	1 PC	RMGCFMIN 2K7 OHM +5% 100MI0W
R417	11066440	1 PC	RMGCFMIN 3K3 OHM +5% 100MI0W
R418	80440400	1 PC	RMGCFMIN 5K6 OHM +5% 100MI0W
R419	11066460	1 PC	RMGCFMIN 8K2 OHM +5% 100MI0W
R420	90574430	1 PC	RMGCFMIN 18K0 OHM +5% 100MI0W
R421	60444370	1 PC	RMGCFMIN 180R0 OHM +5% 100MI0W
R422	60444370	1 PC	RMGCFMIN 180R0 OHM +5% 100MI0W
R423	20471940	1 PC	RMGCFMIN 680R0 OHM +5% 100MI0W
R424	20471940	1 PC	RMGCFMIN 680R0 OHM +5% 100MI0W
R429	90574400	1 PC	RMGCFMIN 470R0 OHM +5% 100MI0W
R430	60444390	1 PC	RMGCFMIN 3K9 OHM +5% 100MI0W

Ref. Designator	Part Number	Qty	Description
R431	11066480	1 PC	RMGCFMIN 47K0 OHM +5% 100MI0W
R432	60444350	1 PC	RMGCFMIN 47R0 OHM +5% 100MI0W
R433	60444350	1 PC	RMGCFMIN 47R0 OHM +5% 100MI0W
R434	60444380	1 PC	RMGCFMIN 270R0 OHM +5% 100MI0W
R435	50886610	1 PC	RMGCFMIN 10K0 OHM +5% 100MI0W
R435	50886630	1 PC	RMGCFMIN 100K0 OHM +5% 100MI0W
R436	11066480	1 PC	RMGCFMIN 47K0 OHM +5% 100MI0W
<i>Miscellaneous</i>			
CN408	55125070	1 PC	CONN 2.0MM 15 MA R NAT MOLEX 35237-1510 0 0
CN409	55125070	1 PC	CONN 2.0MM 15 MA R NAT MOLEX 35237-1510 0 0
CN410	55125070	1 PC	CONN 2.0MM 15 MA R NAT MOLEX 35237-1510 0 0
CN411	55125070	1 PC	CONN 2.0MM 15 MA R NAT MOLEX 35237-1510 0 0
CP205	55123310	1 PC	CONN 2.0MM 4 MA ST NAT LW2002P04 0 0
CP206	55090050	1 PC	CONN 2.0MM 10 MA ST NAT LW2002P10 0 0
CP403	55090080	1 PC	CONN 2.0MM 3 MA ST NAT LW2002P03 0 0
CP404	55090060	1 PC	CONN 2.0MM 7 MA ST NAT LW2002P07 0 0
CP405	55090100	1 PC	CONN 2.0MM 12 MA ST NAT LW2002P12 0 0
JK701	55176350	1 PC	CON PHONO SCKT RCA 6P JW-4105RSS W/GND CAP
JK702	55176330	1 PC	CON PHONO SCKT RCA 4P JW4104RS GND
JK703	55176330	1 PC	CON PHONO SCKT RCA 4P JW4104RS GND
SW401	55145270KX	1 PC	SWITACT VERTICAL TACTILE F/B 50MI0A 12.0V 500MIOOHM 1T 1P
SW402	55145270KX	1 PC	SWITACT VERTICAL TACTILE F/B 50MI0A 12.0V 500MIOOHM 1T 1P
SW403	55145270KX	1 PC	SWITACT VERTICAL TACTILE F/B 50MI0A 12.0V 500MIOOHM 1T 1P
SW404	55145270KX	1 PC	SWITACT VERTICAL TACTILE F/B 50MI0A 12.0V 500MIOOHM 1T 1P
SW405	55145270KX	1 PC	SWITACT VERTICAL TACTILE F/B 50MI0A 12.0V 500MIOOHM 1T 1P
SW406	55145270KX	1 PC	SWITACT VERTICAL TACTILE F/B 50MI0A 12.0V 500MIOOHM 1T 1P
SW407	55145270KX	1 PC	SWITACT VERTICAL TACTILE F/B 50MI0A 12.0V 500MIOOHM 1T 1P
SW408	55145270KX	1 PC	SWITACT VERTICAL TACTILE F/B 50MI0A 12.0V 500MIOOHM 1T 1P
SW409	55145270KX	1 PC	SWITACT VERTICAL TACTILE F/B 50MI0A 12.0V 500MIOOHM 1T 1P
SW410	55145270KX	1 PC	SWITACT VERTICAL TACTILE F/B 50MI0A 12.0V 500MIOOHM 1T 1P
SW411	55145270KX	1 PC	SWITACT VERTICAL TACTILE F/B 50MI0A 12.0V 500MIOOHM 1T 1P
SW412	55145270KX	1 PC	SWITACT VERTICAL TACTILE F/B 50MI0A 12.0V 500MIOOHM 1T 1P
SW413	55145270KX	1 PC	SWITACT VERTICAL TACTILE F/B 50MI0A 12.0V 500MIOOHM 1T 1P
SW414	55145270KX	1 PC	SWITACT VERTICAL TACTILE F/B 50MI0A 12.0V 500MIOOHM 1T 1P
SW415	55145270KX	1 PC	SWITACT VERTICAL TACTILE F/B 50MI0A 12.0V 500MIOOHM 1T 1P
SW416	55145270KX	1 PC	SWITACT VERTICAL TACTILE F/B 50MI0A 12.0V 500MIOOHM 1T 1P
SW417	55145270KX	1 PC	SWITACT VERTICAL TACTILE F/B 50MI0A 12.0V 500MIOOHM 1T 1P
SW418	55145270KX	1 PC	SWITACT VERTICAL TACTILE F/B 50MI0A 12.0V 500MIOOHM 1T 1P
SW419	55145270KX	1 PC	SWITACT VERTICAL TACTILE F/B 50MI0A 12.0V 500MIOOHM 1T 1P
SW420	55145270KX	1 PC	SWITACT VERTICAL TACTILE F/B 50MI0A 12.0V 500MIOOHM 1T 1P
CN401	55175800	1 PC	WIRECONASY UNIQUE 8P 100MM UL1007 PVC DISCRETE 26 1
CN402	55175820	1 PC	WIRECONASY UNIQUE 5P 100MM UL1007 PVC DISCRETE 26 1
CN403	55175870	1 PC	WIRECONASY UNIQUE 3P 600MM UL2547 28 1
CP403	55090070	1 PC	CONN 2.0MM 2 MA ST NAT LW2002P0200T 0 0
CP404	55123310	1 PC	CONN 2.0MM 4 MA ST NAT LW2002P04 0 0
CP405	55123310	1 PC	CONN 2.0MM 4 MA ST NAT LW2002P04 0 0
FN401	55176420	1 PC	AC PUN BRACKET BKT GROUND ET 0.5T AVR520 --
FN402	55176420	1 PC	AC PUN BRACKET BKT GROUND ET 0.5T AVR520 --
HP401	55088400	1 PC	CONN-PHJAC 6.35 ST HORZ EST-J6313 BK 0 0
JA402	55176390	1 PC	CON PHONO SCKT STEREO JACK JW350S
JA403	55176390	1 PC	CON PHONO SCKT STEREO JACK JW350S
JA404	55176390	1 PC	CON PHONO SCKT STEREO JACK JW350S
L401	55168840	1 PC	LF 47U0H +10% 5.8 OHM 70MI0A
L402	55168840	1 PC	LF 47U0H +10% 5.8 OHM 70MI0A
W401	55180140	1 PC	WIRECONASY UNIQUE 1P 200MM UL1007 PVC DISCRETE 18 1

DSP PCB

Capacitors

C103	20288040	1 PC	CCCFMIC 100N0F +80% -20% 16.0V Y5V
------	----------	------	------------------------------------

Ref. Designator	Part Number	Qty	Description
C104	20288040	1 PC	CCCFMIC 100N0F +80% -20% 16.0V Y5V
C111	20288040	1 PC	CCCFMIC 100N0F +80% -20% 16.0V Y5V
C112	20288040	1 PC	CCCFMIC 100N0F +80% -20% 16.0V Y5V
C117	20288040	1 PC	CCCFMIC 100N0F +80% -20% 16.0V Y5V
C118	20288040	1 PC	CCCFMIC 100N0F +80% -20% 16.0V Y5V
C121	20288040	1 PC	CCCFMIC 100N0F +80% -20% 16.0V Y5V
C122	20288040	1 PC	CCCFMIC 100N0F +80% -20% 16.0V Y5V
C126	20288040	1 PC	CCCFMIC 100N0F +80% -20% 16.0V Y5V
C127	20288040	1 PC	CCCFMIC 100N0F +80% -20% 16.0V Y5V
C128	20288040	1 PC	CCCFMIC 100N0F +80% -20% 16.0V Y5V
C129	20288040	1 PC	CCCFMIC 100N0F +80% -20% 16.0V Y5V
C130	20288040	1 PC	CCCFMIC 100N0F +80% -20% 16.0V Y5V
C131	20288040	1 PC	CCCFMIC 100N0F +80% -20% 16.0V Y5V
C134	20288040	1 PC	CCCFMIC 100N0F +80% -20% 16.0V Y5V
C136	20288040	1 PC	CCCFMIC 100N0F +80% -20% 16.0V Y5V
C139	20288040	1 PC	CCCFMIC 100N0F +80% -20% 16.0V Y5V
C140	20288040	1 PC	CCCFMIC 100N0F +80% -20% 16.0V Y5V
C141	20288040	1 PC	CCCFMIC 100N0F +80% -20% 16.0V Y5V
C142	20288040	1 PC	CCCFMIC 100N0F +80% -20% 16.0V Y5V
C143	20288040	1 PC	CCCFMIC 100N0F +80% -20% 16.0V Y5V
C144	20288040	1 PC	CCCFMIC 100N0F +80% -20% 16.0V Y5V
C153	20288040	1 PC	CCCFMIC 100N0F +80% -20% 16.0V Y5V
C154	20288040	1 PC	CCCFMIC 100N0F +80% -20% 16.0V Y5V
C155	10138670	1 PC	CCCFMIC 3N3F +10% -10% 50.0V X7R
C156	10138670	1 PC	CCCFMIC 3N3F +10% -10% 50.0V X7R
C157	20288040	1 PC	CCCFMIC 100N0F +80% -20% 16.0V Y5V
C158	20288040	1 PC	CCCFMIC 100N0F +80% -20% 16.0V Y5V
C159	20288040	1 PC	CCCFMIC 100N0F +80% -20% 16.0V Y5V
C168	20288040	1 PC	CCCFMIC 100N0F +80% -20% 16.0V Y5V
C169	20288040	1 PC	CCCFMIC 100N0F +80% -20% 16.0V Y5V
C170	20288040	1 PC	CCCFMIC 100N0F +80% -20% 16.0V Y5V
C171	20288040	1 PC	CCCFMIC 100N0F +80% -20% 16.0V Y5V
C172	20288040	1 PC	CCCFMIC 100N0F +80% -20% 16.0V Y5V
C181	20288040	1 PC	CCCFMIC 100N0F +80% -20% 16.0V Y5V
C182	20288040	1 PC	CCCFMIC 100N0F +80% -20% 16.0V Y5V
C183	20288040	1 PC	CCCFMIC 100N0F +80% -20% 16.0V Y5V
C184	20288040	1 PC	CCCFMIC 100N0F +80% -20% 16.0V Y5V
C193	20288040	1 PC	CCCFMIC 100N0F +80% -20% 16.0V Y5V
C194	20288040	1 PC	CCCFMIC 100N0F +80% -20% 16.0V Y5V
C195	20288040	1 PC	CCCFMIC 100N0F +80% -20% 16.0V Y5V
C196	20288040	1 PC	CCCFMIC 100N0F +80% -20% 16.0V Y5V
C197	20288040	1 PC	CCCFMIC 100N0F +80% -20% 16.0V Y5V
C200	20288040	1 PC	CCCFMIC 100N0F +80% -20% 16.0V Y5V
C201	20288040	1 PC	CCCFMIC 100N0F +80% -20% 16.0V Y5V
C206	20288040	1 PC	CCCFMIC 100N0F +80% -20% 16.0V Y5V
C207	20288040	1 PC	CCCFMIC 100N0F +80% -20% 16.0V Y5V
C208	20288040	1 PC	CCCFMIC 100N0F +80% -20% 16.0V Y5V
C210	20288040	1 PC	CCCFMIC 100N0F +80% -20% 16.0V Y5V
C3	20288040	1 PC	CCCFMIC 100N0F +80% -20% 16.0V Y5V
C302	20506680	1 PC	CCCFMIC 470P0F +5% -5% 50.0V NP0
C562	10375090	1 PC	CCCFMIC 20P0F +5% -5% 50.0V NP0
C563	10375090	1 PC	CCCFMIC 20P0F +5% -5% 50.0V NP0
C564	20506520	1 PC	CCCFMIC 22P0F +5% -5% 50.0V NP0
C565	20506520	1 PC	CCCFMIC 22P0F +5% -5% 50.0V NP0
C566	20506520	1 PC	CCCFMIC 22P0F +5% -5% 50.0V NP0
C100	20288040	1 PC	CCCFMIC 100N0F +80% -20% 16.0V Y5V
C101	20506640	1 PC	CCCFMIC 220P0F +5% -5% 50.0V NP0
C102	20678070	1 PC	CCCFMIC 330P0F +5% -5% 50.0V NP0
C105	20678070	1 PC	CCCFMIC 330P0F +5% -5% 50.0V NP0
C107	20288060	1 PC	CCCFMIC 220N0F +80% -20% 16.0V Y5V

Ref. Designator	Part Number	Qty	Description
C107	20506640	1 PC	CCCFMIC 220P0F +5% -5% 50.0V NP0
C110	20288040	1 PC	CCCFMIC 100N0F +80% -20% 16.0V Y5V
C113	20506520	1 PC	CCCFMIC 22P0F +5% -5% 50.0V NP0
C114	10138960	1 PC	CCCFMIC 10N0F +10% -10% 50.0V X7R
C115	20506520	1 PC	CCCFMIC 22P0F +5% -5% 50.0V NP0
C116	10138960	1 PC	CCCFMIC 10N0F +10% -10% 50.0V X7R
C119	20288040	1 PC	CCCFMIC 100N0F +80% -20% 16.0V Y5V
C120	20288040	1 PC	CCCFMIC 100N0F +80% -20% 16.0V Y5V
C123	20288040	1 PC	CCCFMIC 100N0F +80% -20% 16.0V Y5V
C124	20506520	1 PC	CCCFMIC 22P0F +5% -5% 50.0V NP0
C125	10138960	1 PC	CCCFMIC 10N0F +10% -10% 50.0V X7R
C135	20288040	1 PC	CCCFMIC 100N0F +80% -20% 16.0V Y5V
C137	20288040	1 PC	CCCFMIC 100N0F +80% -20% 16.0V Y5V
C138	20288040	1 PC	CCCFMIC 100N0F +80% -20% 16.0V Y5V
C145	10138670	1 PC	CCCFMIC 3N3F +10% -10% 50.0V X7R
C146	10138670	1 PC	CCCFMIC 3N3F +10% -10% 50.0V X7R
C147	10138670	1 PC	CCCFMIC 3N3F +10% -10% 50.0V X7R
C148	10138670	1 PC	CCCFMIC 3N3F +10% -10% 50.0V X7R
C149	10138390	1 PC	CCCFMIC 560P0F +10% -10% 50.0V X7R
C150	10138390	1 PC	CCCFMIC 560P0F +10% -10% 50.0V X7R
C151	20678070	1 PC	CCCFMIC 330P0F +5% -5% 50.0V NP0
C152	20678070	1 PC	CCCFMIC 330P0F +5% -5% 50.0V NP0
C160	10138630	1 PC	CCCFMIC 2N7F +10% -10% 50.0V X7R
C161	10138630	1 PC	CCCFMIC 2N7F +10% -10% 50.0V X7R
C162	10138630	1 PC	CCCFMIC 2N7F +10% -10% 50.0V X7R
C163	10138630	1 PC	CCCFMIC 2N7F +10% -10% 50.0V X7R
C164	10138390	1 PC	CCCFMIC 560P0F +10% -10% 50.0V X7R
C165	10138390	1 PC	CCCFMIC 560P0F +10% -10% 50.0V X7R
C166	10138390	1 PC	CCCFMIC 560P0F +10% -10% 50.0V X7R
C167	10138390	1 PC	CCCFMIC 560P0F +10% -10% 50.0V X7R
C173	10138630	1 PC	CCCFMIC 2N7F +10% -10% 50.0V X7R
C174	10138710	1 PC	CCCFMIC 4N7F +10% -10% 50.0V X7R
C175	10138630	1 PC	CCCFMIC 2N7F +10% -10% 50.0V X7R
C176	10138710	1 PC	CCCFMIC 4N7F +10% -10% 50.0V X7R
C177	10138390	1 PC	CCCFMIC 560P0F +10% -10% 50.0V X7R
C178	10138550	1 PC	CCCFMIC 1N0F +10% -10% 50.0V X7R
C178	11059320	1 PC	CCCFMIN 1N0F +10% -10% 50.0V X7R
C179	10138390	1 PC	CCCFMIC 560P0F +10% -10% 50.0V X7R
C180	10138550	1 PC	CCCFMIC 1N0F +10% -10% 50.0V X7R
C185	10138630	1 PC	CCCFMIC 2N7F +10% -10% 50.0V X7R
C185	30939230	1 PC	CCCFMIN 2N7F +10% -10% 50.0V X7R
C186	10138630	1 PC	CCCFMIC 2N7F +10% -10% 50.0V X7R
C187	10138630	1 PC	CCCFMIC 2N7F +10% -10% 50.0V X7R
C187	30939230	1 PC	CCCFMIN 2N7F +10% -10% 50.0V X7R
C188	10138630	1 PC	CCCFMIC 2N7F +10% -10% 50.0V X7R
C189	10138390	1 PC	CCCFMIC 560P0F +10% -10% 50.0V X7R
C189	11058710	1 PC	CCCFMIN 560P0F +5% -5% 50.0V NP0
C190	10138390	1 PC	CCCFMIC 560P0F +10% -10% 50.0V X7R
C190	10138550	1 PC	CCCFMIC 1N0F +10% -10% 50.0V X7R
C190	11058710	1 PC	CCCFMIN 560P0F +5% -5% 50.0V NP0
C191	10138390	1 PC	CCCFMIC 560P0F +10% -10% 50.0V X7R
C192	10138390	1 PC	CCCFMIC 560P0F +10% -10% 50.0V X7R
C192	11058710	1 PC	CCCFMIN 560P0F +5% -5% 50.0V NP0
C198	10138620	1 PC	CCCFMIC 2N2F +10% -10% 50.0V X7R
C199	10138620	1 PC	CCCFMIC 2N2F +10% -10% 50.0V X7R
C202	20506590	1 PC	CCCFMIC 100P0F +5% -5% 50.0V NP0
C203	20506590	1 PC	CCCFMIC 100P0F +5% -5% 50.0V NP0
C204	20506590	1 PC	CCCFMIC 100P0F +5% -5% 50.0V NP0
C205	20506590	1 PC	CCCFMIC 100P0F +5% -5% 50.0V NP0
C554	20506520	1 PC	CCCFMIC 22P0F +5% -5% 50.0V NP0

Ref. Designator	Part Number	Qty	Description
C555	20506520	1 PC	CCCFMIC 22P0F +5% -5% 50.0V NPO
C556	20288040	1 PC	CCCFMIC 100N0F +80% -20% 16.0V Y5V
C557	20288040	1 PC	CCCFMIC 100N0F +80% -20% 16.0V Y5V
C558	20506520	1 PC	CCCFMIC 22P0F +5% -5% 50.0V NPO
C559	20288040	1 PC	CCCFMIC 100N0F +80% -20% 16.0V Y5V
C560	20288040	1 PC	CCCFMIC 100N0F +80% -20% 16.0V Y5V
C561	20288040	1 PC	CCCFMIC 100N0F +80% -20% 16.0V Y5V
C132	20266570	1 PC	CPF 68N0F +10% 50.0V
C301	10121000	1 PC	CE 10U0F +20% 16.0V 85C
C301	15002130	1 PC	CE 10U0F +20% 16.0V 85C
C501	10121000	1 PC	CE 10U0F +20% 16.0V 85C
C502	20268850	1 PC	CE 2U2F +20% 50.0V 85C
C507	10121000	1 PC	CE 10U0F +20% 16.0V 85C
C508	10121000	1 PC	CE 10U0F +20% 16.0V 85C
C509	10121000	1 PC	CE 10U0F +20% 16.0V 85C
C510	10121000	1 PC	CE 10U0F +20% 16.0V 85C
C511	20267830	1 PC	CE 47U0F +20% 16.0V 85C
C511	20342060	1 PC	CE 47U0F +20% 16.0V 85C
C512	10121000	1 PC	CE 10U0F +20% 16.0V 85C
C513	10121000	1 PC	CE 10U0F +20% 16.0V 85C
C514	20251830	1 PC	CE 1U0F +20% 50.0V 85C
C514	20268840	1 PC	CE 1U0F +20% 50.0V 85C
C515	20251830	1 PC	CE 1U0F +20% 50.0V 85C
C515	20268840	1 PC	CE 1U0F +20% 50.0V 85C
C516	10121000	1 PC	CE 10U0F +20% 16.0V 85C
C517	10121000	1 PC	CE 10U0F +20% 16.0V 85C
C518	10121000	1 PC	CE 10U0F +20% 16.0V 85C
C519	10121000	1 PC	CE 10U0F +20% 16.0V 85C
C520	20251830	1 PC	CE 1U0F +20% 50.0V 85C
C520	20268840	1 PC	CE 1U0F +20% 50.0V 85C
C521	20251830	1 PC	CE 1U0F +20% 50.0V 85C
C521	20268840	1 PC	CE 1U0F +20% 50.0V 85C
C522	20267830	1 PC	CE 47U0F +20% 16.0V 85C
C522	20342060	1 PC	CE 47U0F +20% 16.0V 85C
C523	10121000	1 PC	CE 10U0F +20% 16.0V 85C
C524	10121000	1 PC	CE 10U0F +20% 16.0V 85C
C525	10121000	1 PC	CE 10U0F +20% 16.0V 85C
C526	10121000	1 PC	CE 10U0F +20% 16.0V 85C
C527	10121000	1 PC	CE 10U0F +20% 16.0V 85C
C528	10121000	1 PC	CE 10U0F +20% 16.0V 85C
C529	20251830	1 PC	CE 1U0F +20% 50.0V 85C
C529	20268840	1 PC	CE 1U0F +20% 50.0V 85C
C530	20251830	1 PC	CE 1U0F +20% 50.0V 85C
C530	20268840	1 PC	CE 1U0F +20% 50.0V 85C
C531	20267830	1 PC	CE 47U0F +20% 16.0V 85C
C531	20342060	1 PC	CE 47U0F +20% 16.0V 85C
C532	10121000	1 PC	CE 10U0F +20% 16.0V 85C
C533	10121000	1 PC	CE 10U0F +20% 16.0V 85C
C534	10121000	1 PC	CE 10U0F +20% 16.0V 85C
C535	10121000	1 PC	CE 10U0F +20% 16.0V 85C
C536	10121000	1 PC	CE 10U0F +20% 16.0V 85C
C537	10121000	1 PC	CE 10U0F +20% 16.0V 85C
C538	20251830	1 PC	CE 1U0F +20% 50.0V 85C
C538	20268840	1 PC	CE 1U0F +20% 50.0V 85C
C539	20251830	1 PC	CE 1U0F +20% 50.0V 85C
C539	20268840	1 PC	CE 1U0F +20% 50.0V 85C
C540	20267830	1 PC	CE 47U0F +20% 16.0V 85C
C540	20342060	1 PC	CE 47U0F +20% 16.0V 85C
C541	10121000	1 PC	CE 10U0F +20% 16.0V 85C
C542	10121000	1 PC	CE 10U0F +20% 16.0V 85C

Ref. Designator	Part Number	Qty	Description
C543	20269110	1 PC	CE 330U0F +20% 6.3V 85C
C544	20269110	1 PC	CE 330U0F +20% 6.3V 85C
C545	10121000	1 PC	CE 10U0F +20% 16.0V 85C
C546	20252560	1 PC	CE 220U0F +20% 6.3V 85C
C547	10121000	1 PC	CE 10U0F +20% 16.0V 85C
C548	20269070	1 PC	CE 100U0F +20% 25.0V 85C
C549	20269070	1 PC	CE 100U0F +20% 25.0V 85C
51	20472530	1 PC	RCF 4R7 OHM +5% 250MI0W
61	20472530	1 PC	RCF 4R7 OHM +5% 250MI0W
C504	20269180	1 PC	CE 1MI0F +20% 6.3V 85C
C505	20269180	1 PC	CE 1MI0F +20% 6.3V 85C
C506	20269180	1 PC	CE 1MI0F +20% 6.3V 85C

Semiconductors

D201	20496510NR	1 PC	D-SLP 1SS355 35.0V 225MI0A
D202	20496510	1 PC	D-SLP 1SS355 35.0V 225MI0A
D301	20496510	1 PC	D-SLP 1SS355 35.0V 225MI0A
IC101	55125380KV	1 PC	IC-LOWFREQ CS493263-CL DSP
IC101	5512538A	1 PC	IC-LOWFREQ CS493263-CL G VERSION DSP
IC101	5512538A	1 PC	IC-LOWFREQ CS493263-CL G VERSION DSP
IC102	55172540AVR320	1 PC	IC-EPROM AT27LV020A-90JC
IC105	55125420CP	1 PC	IC-LOGIC 74VHC244MX INVERTER CMOS
IC106	55125420	1 PC	IC-LOGIC 74VHC244MX INVERTER CMOS
IC107	55179590KV	1 PC	IC-LOWFREQ CS8414-CS DSP
IC108	55179270	1 PC	IC-LOGIC QUAD 2-INPUT MP 74VHC157MX SOL16 FLIP/FLOP HCMOS
IC109	55133310	1 PC	IC-LOGIC M74HCU04M1R INVERTER HCT
IC110	55179260	1 PC	IC-LOGIC DUAL 4-INPUT MP 74VHC153MX SOL16 FLIP/FLOP HCMOS
IC111	55133310KV	1 PC	IC-LOGIC M74HCU04M1R INVERTER HCT
IC115	55129680KV	1 PC	IC-CONV CS5330A-KS A/D
IC115	55129680KV	1 PC	IC-CONV CS5360-KS A/D
IC116	55179580KV	1 PC	IC-CONV CS4391-KS D/A
IC117	55179580	1 PC	IC-CONV CS4391-KS D/A
IC118	55179580	1 PC	IC-CONV CS4391-KS D/A
IC119	55179580	1 PC	IC-CONV CS4391-KS D/A
IC127	55180060	1 PC	IC-SPECFUNC NJU6324M SOP8 CMOS-CRYSTAL
IC128	5518247ANR	1 PC	IC-MICROCONT CXP82532-XXXQ SUB AVR520
IC128	5518247B	1 PC	IC-MICROCONT CXP82532-197Q SUB AVR520
IC129	55182540	1 PC	IC-REGPOSFXD 2.7V MM1562H NORMAL
Q101	55133330	1 PC	TR-SSD DTC114TKA N 10K0 OHM
D203	20496510	1 PC	D-SLP 1SS355 35.0V 225MI0A
D204	20496510	1 PC	D-SLP 1SS355 35.0V 225MI0A
IC103	55170220CP	1 PC	IC-LOGIC F/F 74VHC574MX FLIP/FLOP HCMOS
IC104	55170220	1 PC	IC-LOGIC F/F 74VHC574MX FLIP/FLOP HCMOS
IC112	55142610CQ	1 PC	IC-OPERAMP NJM2068M DUAL OP
IC113	2071866065	1 PC	IC-LOGIC BU4094BF SHIFT REGISTER CMOS
IC114	5508717065	1 PC	IC-LOGIC BU4051BCF MULTIPLEXER HCT
IC120	55142610	1 PC	IC-OPERAMP NJM2068M DUAL OP
IC122	55142610	1 PC	IC-OPERAMP NJM2068M DUAL OP
IC123	55142610	1 PC	IC-OPERAMP NJM2068M DUAL OP
IC124	55142610	1 PC	IC-OPERAMP NJM2068M DUAL OP
IC126	55142610	1 PC	IC-OPERAMP NJM2068M DUAL OP
IC127	55180060	1 PC	IC-SPECFUNC NJU6324M SOP8 CMOS-CRYSTAL

Resistors

R102	10135940	1 PC	RMGCFMIC 4K7 OHM +5% 62MI5W
R103	10135940	1 PC	RMGCFMIC 4K7 OHM +5% 62MI5W
R104	10135940	1 PC	RMGCFMIC 4K7 OHM +5% 62MI5W
R105	10135010	1 PC	RMGCFMIC 10K0 OHM +5% 62MI5W

Ref. Designator	Part Number	Qty	Description
R106	10135940	1 PC	RMGCFMIC 4K7 OHM +5% 62MI5W
R107	10135010	1 PC	RMGCFMIC 10K0 OHM +5% 62MI5W
R108	10135010	1 PC	RMGCFMIC 10K0 OHM +5% 62MI5W
R109	10135010	1 PC	RMGCFMIC 10K0 OHM +5% 62MI5W
R110	10135010	1 PC	RMGCFMIC 10K0 OHM +5% 62MI5W
R111	10135010	1 PC	RMGCFMIC 10K0 OHM +5% 62MI5W
R112	10135010	1 PC	RMGCFMIC 10K0 OHM +5% 62MI5W
R113	10135010	1 PC	RMGCFMIC 10K0 OHM +5% 62MI5W
R114	10135010	1 PC	RMGCFMIC 10K0 OHM +5% 62MI5W
R115	10135010	1 PC	RMGCFMIC 10K0 OHM +5% 62MI5W
R116	10135010	1 PC	RMGCFMIC 10K0 OHM +5% 62MI5W
R117	10135010	1 PC	RMGCFMIC 10K0 OHM +5% 62MI5W
R118	10135010	1 PC	RMGCFMIC 10K0 OHM +5% 62MI5W
R119	10135940	1 PC	RMGCFMIC 4K7 OHM +5% 62MI5W
R120	10135010	1 PC	RMGCFMIC 10K0 OHM +5% 62MI5W
R121	10135010	1 PC	RMGCFMIC 10K0 OHM +5% 62MI5W
R122	10134710	1 PC	RMGCFMIC 75R0 OHM +5% 62MI5W
R123	10135220	1 PC	RMGCFMIC 47K0 OHM +5% 62MI5W
R124	10134930	1 PC	RMGCFMIC 560R0 OHM +5% 62MI5W
R125	10134710	1 PC	RMGCFMIC 75R0 OHM +5% 62MI5W
R126	10135220	1 PC	RMGCFMIC 47K0 OHM +5% 62MI5W
R127	10134930	1 PC	RMGCFMIC 560R0 OHM +5% 62MI5W
R128	10135220	1 PC	RMGCFMIC 47K0 OHM +5% 62MI5W
R129	10135860	1 PC	RMGCFMIC 2K2 OHM +5% 62MI5W
R130	10135860	1 PC	RMGCFMIC 2K2 OHM +5% 62MI5W
R131	10135220	1 PC	RMGCFMIC 47K0 OHM +5% 62MI5W
R132	10134410	1 PC	RMGCFMIC 10R0 OHM +5% 62MI5W
R133	10134740	1 PC	RMGCFMIC 100R0 OHM +5% 62MI5W
R134	10134920	1 PC	RMGCFMIC 510R0 OHM +5% 62MI5W
R135	10134910	1 PC	RMGCFMIC 470R0 OHM +5% 62MI5W
R136	10134410	1 PC	RMGCFMIC 10R0 OHM +5% 62MI5W
R137	10135770	1 PC	RMGCFMIC 1K0 OHM +5% 62MI5W
R138	10134410	1 PC	RMGCFMIC 10R0 OHM +5% 62MI5W
R139	10135770	1 PC	RMGCFMIC 1K0 OHM +5% 62MI5W
R140	10134740	1 PC	RMGCFMIC 100R0 OHM +5% 62MI5W
R142	10135860	1 PC	RMGCFMIC 2K2 OHM +5% 62MI5W
R143	10135220	1 PC	RMGCFMIC 47K0 OHM +5% 62MI5W
R144	10134910	1 PC	RMGCFMIC 470R0 OHM +5% 62MI5W
R145	10135220	1 PC	RMGCFMIC 47K0 OHM +5% 62MI5W
R146	10134710	1 PC	RMGCFMIC 75R0 OHM +5% 62MI5W
R147	10134560	1 PC	RMGCFMIC 27R0 OHM +5% 62MI5W
R147	10134650	1 PC	RMGCFMIC 47R0 OHM +5% 62MI5W
R148	10135860	1 PC	RMGCFMIC 2K2 OHM +5% 62MI5W
R149	10135220	1 PC	RMGCFMIC 47K0 OHM +5% 62MI5W
R150	10135860	1 PC	RMGCFMIC 2K2 OHM +5% 62MI5W
R151	10135220	1 PC	RMGCFMIC 47K0 OHM +5% 62MI5W
R152	10134410	1 PC	RMGCFMIC 10R0 OHM +5% 62MI5W
R153	10134910	1 PC	RMGCFMIC 470R0 OHM +5% 62MI5W
R154	10134920	1 PC	RMGCFMIC 510R0 OHM +5% 62MI5W
R155	10134740	1 PC	RMGCFMIC 100R0 OHM +5% 62MI5W
R156	10135770	1 PC	RMGCFMIC 1K0 OHM +5% 62MI5W
R157	10135770	1 PC	RMGCFMIC 1K0 OHM +5% 62MI5W
R158	10135770	1 PC	RMGCFMIC 1K0 OHM +5% 62MI5W
R159	10135770	1 PC	RMGCFMIC 1K0 OHM +5% 62MI5W
R162	10134740	1 PC	RMGCFMIC 100R0 OHM +5% 62MI5W
R163	10134740	1 PC	RMGCFMIC 100R0 OHM +5% 62MI5W
R165	10134740	1 PC	RMGCFMIC 100R0 OHM +5% 62MI5W
R165	10134830	1 PC	RMGCFMIC 220R0 OHM +5% 62MI5W
R166	10134740	1 PC	RMGCFMIC 100R0 OHM +5% 62MI5W
R166	10134830	1 PC	RMGCFMIC 220R0 OHM +5% 62MI5W

Ref. Designator	Part Number	Qty	Description
R167	10135010	1 PC	RMGCFMIC 10K0 OHM +5% 62MI5W
R168	10135010	1 PC	RMGCFMIC 10K0 OHM +5% 62MI5W
R169	10134830	1 PC	RMGCFMIC 220R0 OHM +5% 62MI5W
R169	10134910	1 PC	RMGCFMIC 470R0 OHM +5% 62MI5W
R170	10135010	1 PC	RMGCFMIC 10K0 OHM +5% 62MI5W
R171	10135010	1 PC	RMGCFMIC 10K0 OHM +5% 62MI5W
R172	50886540	1 PC	RMGCFMIN 330R0 OHM +5% 100MI0W
R173	10134740	1 PC	RMGCFMIC 100R0 OHM +5% 62MI5W
R173	10134830	1 PC	RMGCFMIC 220R0 OHM +5% 62MI5W
R173	50886540	1 PC	RMGCFMIN 330R0 OHM +5% 100MI0W
R174	10134740	1 PC	RMGCFMIC 100R0 OHM +5% 62MI5W
R174	10134830	1 PC	RMGCFMIC 220R0 OHM +5% 62MI5W
R174	50886540	1 PC	RMGCFMIN 330R0 OHM +5% 100MI0W
R175	10135950	1 PC	RMGCFMIC 5K1 OHM +5% 62MI5W
R176	10135950	1 PC	RMGCFMIC 5K1 OHM +5% 62MI5W
R177	10135950	1 PC	RMGCFMIC 5K1 OHM +5% 62MI5W
R178	10135950	1 PC	RMGCFMIC 5K1 OHM +5% 62MI5W
R179	10135960	1 PC	RMGCFMIC 5K6 OHM +5% 62MI5W
R180	10135960	1 PC	RMGCFMIC 5K6 OHM +5% 62MI5W
R181	10135960	1 PC	RMGCFMIC 5K6 OHM +5% 62MI5W
R182	10135790	1 PC	RMGCFMIC 1K2 OHM +5% 62MI5W
R183	10135790	1 PC	RMGCFMIC 1K2 OHM +5% 62MI5W
R184	10135790	1 PC	RMGCFMIC 1K2 OHM +5% 62MI5W
R185	10135790	1 PC	RMGCFMIC 1K2 OHM +5% 62MI5W
R186	10135960	1 PC	RMGCFMIC 5K6 OHM +5% 62MI5W
R187	10134930	1 PC	RMGCFMIC 560R0 OHM +5% 62MI5W
R188	10134930	1 PC	RMGCFMIC 560R0 OHM +5% 62MI5W
R189	10135400	1 PC	RMGCFMIC 180K0 OHM +5% 62MI5W
R190	10135400	1 PC	RMGCFMIC 180K0 OHM +5% 62MI5W
R191	10135960	1 PC	RMGCFMIC 5K6 OHM +5% 62MI5W
R192	10135960	1 PC	RMGCFMIC 5K6 OHM +5% 62MI5W
R193	10135960	1 PC	RMGCFMIC 5K6 OHM +5% 62MI5W
R194	10135960	1 PC	RMGCFMIC 5K6 OHM +5% 62MI5W
R195	10135960	1 PC	RMGCFMIC 5K6 OHM +5% 62MI5W
R196	10135960	1 PC	RMGCFMIC 5K6 OHM +5% 62MI5W
R197	10135790	1 PC	RMGCFMIC 1K2 OHM +5% 62MI5W
R198	10135790	1 PC	RMGCFMIC 1K2 OHM +5% 62MI5W
R199	10135960	1 PC	RMGCFMIC 5K6 OHM +5% 62MI5W
R200	10135790	1 PC	RMGCFMIC 1K2 OHM +5% 62MI5W
R201	10135790	1 PC	RMGCFMIC 1K2 OHM +5% 62MI5W
R202	10135960	1 PC	RMGCFMIC 5K6 OHM +5% 62MI5W
R203	10134930	1 PC	RMGCFMIC 560R0 OHM +5% 62MI5W
R204	10134930	1 PC	RMGCFMIC 560R0 OHM +5% 62MI5W
R205	10135340	1 PC	RMGCFMIC 100K0 OHM +5% 62MI5W
R206	10135340	1 PC	RMGCFMIC 100K0 OHM +5% 62MI5W
R207	10135400	1 PC	RMGCFMIC 180K0 OHM +5% 62MI5W
R208	10135400	1 PC	RMGCFMIC 180K0 OHM +5% 62MI5W
R209	10135960	1 PC	RMGCFMIC 5K6 OHM +5% 62MI5W
R210	10135960	1 PC	RMGCFMIC 5K6 OHM +5% 62MI5W
R211	10135950	1 PC	RMGCFMIC 5K1 OHM +5% 62MI5W
R212	10135950	1 PC	RMGCFMIC 5K1 OHM +5% 62MI5W
R213	10135960	1 PC	RMGCFMIC 5K6 OHM +5% 62MI5W
R214	10135960	1 PC	RMGCFMIC 5K6 OHM +5% 62MI5W
R215	10135790	1 PC	RMGCFMIC 1K2 OHM +5% 62MI5W
R216	10135790	1 PC	RMGCFMIC 1K2 OHM +5% 62MI5W
R217	10135790	1 PC	RMGCFMIC 1K2 OHM +5% 62MI5W
R218	10135790	1 PC	RMGCFMIC 1K2 OHM +5% 62MI5W
R219	10135960	1 PC	RMGCFMIC 5K6 OHM +5% 62MI5W
R220	10135960	1 PC	RMGCFMIC 5K6 OHM +5% 62MI5W
R221	10134930	1 PC	RMGCFMIC 560R0 OHM +5% 62MI5W

Ref. Designator	Part Number	Qty	Description
R222	10134930	1 PC	RMGCFMIC 560R0 OHM +5% 62MI5W
R223	10135340	1 PC	RMGCFMIC 100K0 OHM +5% 62MI5W
R224	10135340	1 PC	RMGCFMIC 100K0 OHM +5% 62MI5W
R225	10135820	1 PC	RMGCFMIC 1K5 OHM +5% 62MI5W
R226	10135770	1 PC	RMGCFMIC 1K0 OHM +5% 62MI5W
R227	10135960	1 PC	RMGCFMIC 5K6 OHM +5% 62MI5W
R228	10135960	1 PC	RMGCFMIC 5K6 OHM +5% 62MI5W
R229	10135960	1 PC	RMGCFMIC 5K6 OHM +5% 62MI5W
R230	10135960	1 PC	RMGCFMIC 5K6 OHM +5% 62MI5W
R231	10135960	1 PC	RMGCFMIC 5K6 OHM +5% 62MI5W
R232	10135960	1 PC	RMGCFMIC 5K6 OHM +5% 62MI5W
R233	10135790	1 PC	RMGCFMIC 1K2 OHM +5% 62MI5W
R234	10135790	1 PC	RMGCFMIC 1K2 OHM +5% 62MI5W
R235	10135790	1 PC	RMGCFMIC 1K2 OHM +5% 62MI5W
R236	10135790	1 PC	RMGCFMIC 1K2 OHM +5% 62MI5W
R237	10135960	1 PC	RMGCFMIC 5K6 OHM +5% 62MI5W
R238	10135960	1 PC	RMGCFMIC 5K6 OHM +5% 62MI5W
R239	10134930	1 PC	RMGCFMIC 560R0 OHM +5% 62MI5W
R240	10134930	1 PC	RMGCFMIC 560R0 OHM +5% 62MI5W
R241	10135340	1 PC	RMGCFMIC 100K0 OHM +5% 62MI5W
R242	10135340	1 PC	RMGCFMIC 100K0 OHM +5% 62MI5W
R243	10135010	1 PC	RMGCFMIC 10K0 OHM +5% 62MI5W
R244	10134410	1 PC	RMGCFMIC 10R0 OHM +5% 62MI5W
R244	10135010	1 PC	RMGCFMIC 10K0 OHM +5% 62MI5W
R246	10135220	1 PC	RMGCFMIC 47K0 OHM +5% 62MI5W
R247	10135010	1 PC	RMGCFMIC 10K0 OHM +5% 62MI5W
R248	10135010	1 PC	RMGCFMIC 10K0 OHM +5% 62MI5W
R249	10135010	1 PC	RMGCFMIC 10K0 OHM +5% 62MI5W
R250	10134780	1 PC	RMGCFMIC 150R0 OHM +5% 62MI5W
R251	10134780	1 PC	RMGCFMIC 150R0 OHM +5% 62MI5W
R252	10134780	1 PC	RMGCFMIC 150R0 OHM +5% 62MI5W
R253	10134780	1 PC	RMGCFMIC 150R0 OHM +5% 62MI5W
R254	10135010	1 PC	RMGCFMIC 10K0 OHM +5% 62MI5W
R255	10135010	1 PC	RMGCFMIC 10K0 OHM +5% 62MI5W
R256	10135010	1 PC	RMGCFMIC 10K0 OHM +5% 62MI5W
R257	10135010	1 PC	RMGCFMIC 10K0 OHM +5% 62MI5W
R258	10135010	1 PC	RMGCFMIC 10K0 OHM +5% 62MI5W
R259	10135010	1 PC	RMGCFMIC 10K0 OHM +5% 62MI5W
R260	10135090	1 PC	RMGCFMIC 20K0 OHM +5% 62MI5W
R261	10135090	1 PC	RMGCFMIC 20K0 OHM +5% 62MI5W
R262	10135220	1 PC	RMGCFMIC 47K0 OHM +5% 62MI5W
R263	10135220	1 PC	RMGCFMIC 47K0 OHM +5% 62MI5W
R264	10135770	1 PC	RMGCFMIC 1K0 OHM +5% 62MI5W
R265	10135940	1 PC	RMGCFMIC 4K7 OHM +5% 62MI5W
R301	10134410	1 PC	RMGCFMIC 10R0 OHM +5% 62MI5W
R302	10134410	1 PC	RMGCFMIC 10R0 OHM +5% 62MI5W
R303	10134410	1 PC	RMGCFMIC 10R0 OHM +5% 62MI5W
R304	10134410	1 PC	RMGCFMIC 10R0 OHM +5% 62MI5W
R305	10134410	1 PC	RMGCFMIC 10R0 OHM +5% 62MI5W
R306	10134410	1 PC	RMGCFMIC 10R0 OHM +5% 62MI5W
R307	10134410	1 PC	RMGCFMIC 10R0 OHM +5% 62MI5W
R308	10134410	1 PC	RMGCFMIC 10R0 OHM +5% 62MI5W
R309	10134410	1 PC	RMGCFMIC 10R0 OHM +5% 62MI5W
R310	10134410	1 PC	RMGCFMIC 10R0 OHM +5% 62MI5W
R311	10134410	1 PC	RMGCFMIC 10R0 OHM +5% 62MI5W
R312	10134910	1 PC	RMGCFMIC 470R0 OHM +5% 62MI5W
R313	10135940	1 PC	RMGCFMIC 4K7 OHM +5% 62MI5W
R314	10135770	1 PC	RMGCFMIC 1K0 OHM +5% 62MI5W
R315	10134410	1 PC	RMGCFMIC 10R0 OHM +5% 62MI5W
R316	10134410	1 PC	RMGCFMIC 10R0 OHM +5% 62MI5W

Ref. Designator	Part Number	Qty	Description
R317	10134410	1 PC	RMGCFMIC 10R0 OHM +5% 62MI5W
R318	10134410	1 PC	RMGCFMIC 10R0 OHM +5% 62MI5W
R319	10134410	1 PC	RMGCFMIC 10R0 OHM +5% 62MI5W
R320	10134410	1 PC	RMGCFMIC 10R0 OHM +5% 62MI5W
R321	10135770	1 PC	RMGCFMIC 1K0 OHM +5% 62MI5W
R160	10134740	1 PC	RMGCFMIC 100R0 OHM +5% 62MI5W
R161	10134740	1 PC	RMGCFMIC 100R0 OHM +5% 62MI5W
R164	10134740	1 PC	RMGCFMIC 100R0 OHM +5% 62MI5W
R164	10134950	1 PC	RMGCFMIC 680R0 OHM +5% 62MI5W
R245	10134410	1 PC	RMGCFMIC 10R0 OHM +5% 62MI5W
R322	10134740	1 PC	RMGCFMIC 100R0 OHM +5% 62MI5W
R323	10134740	1 PC	RMGCFMIC 100R0 OHM +5% 62MI5W
<i>Miscellaneous</i>			
BD11	55126690	1 PC	FBEAD SURFACE MT 2500OHM FCM2012H-252T02
BD12	55126690	1 PC	FBEAD SURFACE MT 2500OHM FCM2012H-252T02
BD14	55126690	1 PC	FBEAD SURFACE MT 2500OHM FCM2012H-252T02
BD15	55126690	1 PC	FBEAD SURFACE MT 2500OHM FCM2012H-252T02
BD16	55126690	1 PC	FBEAD SURFACE MT 2500OHM FCM2012H-252T02
BD17	55126690	1 PC	FBEAD SURFACE MT 2500OHM FCM2012H-252T02
BD20	55126530	1 PC	FBEAD SURFACE MT 300OHM CHIP FERRITE BEAD U
BD20	55126650	1 PC	FBEAD SURFACE MT 300OHM FCM2012V-301T07
BD21	55126530	1 PC	FBEAD SURFACE MT 300OHM CHIP FERRITE BEAD U
BD21	55126650	1 PC	FBEAD SURFACE MT 300OHM FCM2012V-301T07
BD10	55126690	1 PC	FBEAD SURFACE MT 2500OHM FCM2012H-252T02
BD13	55126690	1 PC	FBEAD SURFACE MT 2500OHM FCM2012H-252T02
BD18	55126690	1 PC	FBEAD SURFACE MT 2500OHM FCM2012H-252T02
BD19	55126530	1 PC	FBEAD SURFACE MT 300OHM CHIP FERRITE BEAD U
BD19	55126650	1 PC	FBEAD SURFACE MT 300OHM FCM2012V-301T07
BD22	55126530	1 PC	FBEAD SURFACE MT 300OHM CHIP FERRITE BEAD U
BD22	55126650	1 PC	FBEAD SURFACE MT 300OHM FCM2012V-301T07
BD23	55126530	1 PC	FBEAD SURFACE MT 300OHM CHIP FERRITE BEAD U
BD23	55126650	1 PC	FBEAD SURFACE MT 300OHM FCM2012V-301T07
BD24	55126690	1 PC	FBEAD SURFACE MT 2500OHM FCM2012H-252T02
BD25	55126690	1 PC	FBEAD SURFACE MT 2500OHM FCM2012H-252T02
CN102	55174670	1 PC	CONN 2.0MM 19 MA R NAT SOCKET MOLEX 35237-1910 0 0
CN103	55174660	1 PC	CONN 2.0MM 17 MA R NAT SOCKET MOLEX 35237-1710 0 0
CN104	55123390	1 PC	CONN 2.0MM 5 MA R NAT -- 0 0
CN105	55175860	1 PC	WIRECONASY UNIQUE 5P 480MM UL1007 PVC DISCRETE 26 1
CN106	55191240	1 PC	WIRECONASY UNIQUE 3P 500MM UL1007 PVC DISCRETE 26 1
CP101	55123390	1 PC	CONN 2.0MM 5 MA R NAT -- 0 0
CP102	55123390	1 PC	CONN 2.0MM 5 MA R NAT -- 0 0
CP106	55191240	1 PC	WIRECONASY UNIQUE 3P 500MM UL1007 PVC DISCRETE 26 1
JAC1	55175240	1 PC	CON PHONO SCKT RCA 1P W/GND JE010003MG
JAC2	55125430	1 PC	D-LEM TORX178B RD RND CL
JK101	55125430	1 PC	D-LEM TORX178B RD RND CL
JK102	55125430	1 PC	D-LEM TORX178B RD RND CL
JK103	55125440	1 PC	D-LEM TOTX178B RD RND CL
JK105	55191600	1 PC	CON PHONO SCKT RCA 2P W/GNDCAP JW-1502SN OO
JK106	55175950	1 PC	CON PHONO SCKT RCA 1P W/GND JE010003MN
OSC101	55126130	1 PC	VCXO 12M288 HZ +50 PPM -50 PPM 0 OHM
OSC102	55126140	1 PC	CRESONATOR 10M0 HZ 25.0 OHM 0F
RY101	55179930	1 PC	RELAYPWR 5.0V 166.0OHM 1.0A 24.0V
SHILD	55182550	1 PC	AC PUN SHIELD DIGITAL ET
T101	55176540	1 PC	TFPULSE TRANSFORMER 110UH FP-110 FERRIT MAGNET
T102	55176550	1 PC	TFPULSE TRANSFORMER 110UH FP-120 FERRIT MAGNET
W1	55180120	1 PC	WIRECONASY UNIQUE 1P 100MM UL1007 PVC DISCRETE 18 1
J2	10328750	1 PC	RMGCFMIC 0 OHM +0% 62MI5W
J3	10328750	1 PC	RMGCFMIC 0 OHM +0% 62MI5W

Ref. Designator	Part Number	Qty	Description
J999	10328750	1 PC	RMGCFMIC 0 OHM +0% 62MI5W
Video PCB			
<i>Capacitors</i>			
C608	11058670	1 PC	CCCFMIN 100P0F +5% -5% 50.0V NP0
C609	11058670	1 PC	CCCFMIN 100P0F +5% -5% 50.0V NP0
C611	11058670	1 PC	CCCFMIN 100P0F +5% -5% 50.0V NP0
C612	11058670	1 PC	CCCFMIN 100P0F +5% -5% 50.0V NP0
C619	11058670	1 PC	CCCFMIN 100P0F +5% -5% 50.0V NP0
C620	11058670	1 PC	CCCFMIN 100P0F +5% -5% 50.0V NP0
C629	11059340	1 PC	CCCFMIN 10N0F +10% -10% 50.0V X7R
C632	11059340	1 PC	CCCFMIN 10N0F +10% -10% 50.0V X7R
C637	11058670	1 PC	CCCFMIN 100P0F +5% -5% 50.0V NP0
C638	11058670	1 PC	CCCFMIN 100P0F +5% -5% 50.0V NP0
C640	11058670	1 PC	CCCFMIN 100P0F +5% -5% 50.0V NP0
C641	11058670	1 PC	CCCFMIN 100P0F +5% -5% 50.0V NP0
C642	11058670	1 PC	CCCFMIN 100P0F +5% -5% 50.0V NP0
C657	20267290	1 PC	CCCFMIN 100N0F +80% -20% 50.0V Y5V
C658	11058670	1 PC	CCCFMIN 100P0F +5% -5% 50.0V NP0
C659	11058670	1 PC	CCCFMIN 100P0F +5% -5% 50.0V NP0
C670	11058670	1 PC	CCCFMIN 100P0F +5% -5% 50.0V NP0
C673	11059340	1 PC	CCCFMIN 10N0F +10% -10% 50.0V X7R
C674	40435180	1 PC	CCCFMIN 47P0F +5% -5% 50.0V NP0
C674	40435180	1 PC	CCCFMIN 47P0F +5% -5% 50.0V NP0
C676	50882360	1 PC	CCCFMIN 33P0F +5% -5% 50.0V NP0
C681	11058670	1 PC	CCCFMIN 100P0F +5% -5% 50.0V NP0
C686	11059340	1 PC	CCCFMIN 10N0F +10% -10% 50.0V X7R
C688	11059330	1 PC	CCCFMIN 2N2F +10% -10% 50.0V X7R
C690	11059320	1 PC	CCCFMIN 1N0F +10% -10% 50.0V X7R
C696	11058670	1 PC	CCCFMIN 100P0F +5% -5% 50.0V NP0
C697	20267290	1 PC	CCCFMIN 100N0F +80% -20% 50.0V Y5V
CC602	20267290	1 PC	CCCFMIN 100N0F +80% -20% 50.0V Y5V
CC604	20267290	1 PC	CCCFMIN 100N0F +80% -20% 50.0V Y5V
CC607	20267290	1 PC	CCCFMIN 100N0F +80% -20% 50.0V Y5V
CC609	20267290	1 PC	CCCFMIN 100N0F +80% -20% 50.0V Y5V
CF603	20267290	1 PC	CCCFMIN 100N0F +80% -20% 50.0V Y5V
CF606	20267290	1 PC	CCCFMIN 100N0F +80% -20% 50.0V Y5V
CF613	20267290	1 PC	CCCFMIN 100N0F +80% -20% 50.0V Y5V
C601	20268880	1 PC	CE 10U0F +20% 50.0V 85C
C602	20268880	1 PC	CE 10U0F +20% 50.0V 85C
C602	20269080	1 PC	CE 220U0F +20% 10.0V 85C
C603	20268880	1 PC	CE 10U0F +20% 50.0V 85C
C604	20268880	1 PC	CE 10U0F +20% 50.0V 85C
C604	20269080	1 PC	CE 220U0F +20% 10.0V 85C
C605	20268880	1 PC	CE 10U0F +20% 50.0V 85C
C606	20252670	1 PC	CE 470U0F +20% 10.0V 85C
C613	20268880	1 PC	CE 10U0F +20% 50.0V 85C
C613	20269080	1 PC	CE 220U0F +20% 10.0V 85C
C614	20268880	1 PC	CE 10U0F +20% 50.0V 85C
C614	20269080	1 PC	CE 220U0F +20% 10.0V 85C
C615	20252670	1 PC	CE 470U0F +20% 10.0V 85C
C616	20268880	1 PC	CE 10U0F +20% 50.0V 85C
C616	20269080	1 PC	CE 220U0F +20% 10.0V 85C
C617	20268880	1 PC	CE 10U0F +20% 50.0V 85C
C617	20269080	1 PC	CE 220U0F +20% 10.0V 85C
C618	20252670	1 PC	CE 470U0F +20% 10.0V 85C
C621	20268880	1 PC	CE 10U0F +20% 50.0V 85C
C622	20268880	1 PC	CE 10U0F +20% 50.0V 85C
C622	20269080	1 PC	CE 220U0F +20% 10.0V 85C

Ref. Designator	Part Number	Qty	Description
C623	20268880	1 PC	CE 10U0F +20% 50.0V 85C
C624	20268880	1 PC	CE 10U0F +20% 50.0V 85C
C624	20269080	1 PC	CE 220U0F +20% 10.0V 85C
C625	20268880	1 PC	CE 10U0F +20% 50.0V 85C
C626	20252670	1 PC	CE 470U0F +20% 10.0V 85C
C627	20268880	1 PC	CE 10U0F +20% 50.0V 85C
C628	20252670	1 PC	CE 470U0F +20% 10.0V 85C
C628	40433090	1 PC	CE 1M10F +20% 6.3V 85C
C630	20268880	1 PC	CE 2U2F +20% 50.0V 85C
C631	20268880	1 PC	CE 10U0F +20% 50.0V 85C
C633	20268940	1 PC	CE 100U0F +20% 10.0V 85C
C639	20268840	1 PC	CE 1U0F +20% 50.0V 85C
C647	20252670	1 PC	CE 470U0F +20% 10.0V 85C
C647	40433090	1 PC	CE 1M10F +20% 6.3V 85C
C650	20252670	1 PC	CE 470U0F +20% 10.0V 85C
C651	20252670	1 PC	CE 470U0F +20% 10.0V 85C
C652	20252670	1 PC	CE 470U0F +20% 10.0V 85C
C653	20252670	1 PC	CE 470U0F +20% 10.0V 85C
C664	20252670	1 PC	CE 470U0F +20% 10.0V 85C
C665	20252670	1 PC	CE 470U0F +20% 10.0V 85C
C671	20268960	1 PC	CE 330N0F +20% 50.0V 85C
C672	20268940	1 PC	CE 100U0F +20% 10.0V 85C
C675	20268840	1 PC	CE 1U0F +20% 50.0V 85C
C678	40433350	1 PC	CC 18P0F +5% -5% 50.0V NP0
C679	20268880	1 PC	CE 10U0F +20% 50.0V 85C
C679	20269080	1 PC	CE 220U0F +20% 10.0V 85C
C682	20268940	1 PC	CE 100U0F +20% 10.0V 85C
C683	80434590	1 PC	CC 22P0F +5% -5% 50.0V NP0
C684	80434590	1 PC	CC 22P0F +5% -5% 50.0V NP0
C685	20268940	1 PC	CE 100U0F +20% 10.0V 85C
C687	20268940	1 PC	CE 100U0F +20% 10.0V 85C
C691	20268840	1 PC	CE 1U0F +20% 50.0V 85C
C698	20267830	1 PC	CE 47U0F +20% 16.0V 85C
C699	20267830	1 PC	CE 47U0F +20% 16.0V 85C
CC601	20268880	1 PC	CE 10U0F +20% 50.0V 85C
CC603	20268880	1 PC	CE 10U0F +20% 50.0V 85C
CC606	20268880	1 PC	CE 10U0F +20% 50.0V 85C
CF601	20268880	1 PC	CE 10U0F +20% 50.0V 85C
CF602	20268880	1 PC	CE 10U0F +20% 50.0V 85C
CF604	20268880	1 PC	CE 10U0F +20% 50.0V 85C
CF604	20269080	1 PC	CE 220U0F +20% 10.0V 85C
CF605	20268880	1 PC	CE 10U0F +20% 50.0V 85C
CF611	20268880	1 PC	CE 10U0F +20% 50.0V 85C
CF611	20269080	1 PC	CE 220U0F +20% 10.0V 85C
CF612	20268880	1 PC	CE 10U0F +20% 50.0V 85C
CS607	20268880	1 PC	CE 10U0F +20% 50.0V 85C

Semiconductors

D601	20496510	1 PC	D-SLP 1SS355 35.0V 225MI0A
D602	20496510	1 PC	D-SLP 1SS355 35.0V 225MI0A
D603	20496510	1 PC	D-SLP 1SS355 35.0V 225MI0A
D604	20496510	1 PC	D-SLP 1SS355 35.0V 225MI0A
D605	20496510	1 PC	D-SLP 1SS355 35.0V 225MI0A
D606	20496510	1 PC	D-SLP 1SS355 35.0V 225MI0A
D607	20496510	1 PC	D-SLP 1SS355 35.0V 225MI0A
D608	20496510	1 PC	D-SLP 1SS355 35.0V 225MI0A
D609	20496510	1 PC	D-SLP 1SS355 35.0V 225MI0A
D611	20496510	1 PC	D-SLP 1SS355 35.0V 225MI0A
D612	20496510	1 PC	D-SLP 1SS355 35.0V 225MI0A

Ref. Designator	Part Number	Qty	Description
D613	20496510	1 PC	D-SLP 1SS355 35.0V 225M10A
D614	20496510	1 PC	D-SLP 1SS355 35.0V 225M10A
D615	20496510	1 PC	D-SLP 1SS355 35.0V 225M10A
IC601	55125370CP	1 PC	IC-SWITCH NJM2296 SOP16 VIDEO ALSO 55125370NR
IC602	55125370CP	1 PC	IC-SWITCH NJM2296 SOP16 VIDEO
IC603	55125370CP	1 PC	IC-SWITCH NJM2296 SOP16 VIDEO
IC605	2071866065	1 PC	IC-LOGIC BU4094BF SHIFT REGISTER CMOS
IC606	2071866065	1 PC	IC-LOGIC BU4094BF SHIFT REGISTER CMOS
Q601	55133180	1 PC	TR-SSD DTC114YKA N 10K0 OHM 47K0 OHM
Q606	55133190	1 PC	TR-SSD DTA114YKA P 10K0 OHM 47K0 OHM
Q607	55133180	1 PC	TR-SSD DTC114YKA N 10K0 OHM 47K0 OHM
Q608	55133190	1 PC	TR-SSD DTA114YKA P 10K0 OHM 47K0 OHM
Q611	55133180	1 PC	TR-SSD DTC114YKA N 10K0 OHM 47K0 OHM
Q613	55133180	1 PC	TR-SSD DTC114YKA N 10K0 OHM 47K0 OHM
Q602	55157120	1 PC	TR-SLPLF KTC2874 A N 300M10A 20V
Q603	55157120	1 PC	TR-SLPLF KTC2874 A N 300M10A 20V
Q604	55157120	1 PC	TR-SLPLF KTC2874 A N 300M10A 20V
Q605	55101930	1 PC	TR-SLPLF 2SA933ASR P -3.0A -20V
Q605	55180600	1 PC	TR-SLPLF 2SA933S P -150M10A -50V
Q609	55157120	1 PC	TR-SLPLF KTC2874 A N 300M10A 20V
Q610	55133290	1 PC	TR-SLPLF KTD1302 B N 300M10A 20V
Q614	55133250	1 PC	TR-SLPLF 2SC1740S R N 150M10A 50V
Q615	55157120	1 PC	TR-SLPLF KTC2874 A N 300M10A 20V
Q616	55157120	1 PC	TR-SLPLF KTC2874 A N 300M10A 20V
Q619	55133250	1 PC	TR-SLPLF 2SC1740S R N 150M10A 50V
Q620	55101930	1 PC	TR-SLPLF 2SA933ASR P -3.0A -20V
Q620	55180600	1 PC	TR-SLPLF 2SA933S P -150M10A -50V
IC607	55179610	1 PC	IC-SPECFUNC M35013 OSD
IC609	40440440	1 PC	IC-LIN BA7046 2856 A0 00

Resistors

R615	20471990	1 PC	RMGCFMIN 12K0 OHM +5% 100M10W
R618	20471950	1 PC	RMGCFMIN 1K0 OHM +5% 100M10W
R621	50886610	1 PC	RMGCFMIN 10K0 OHM +5% 100M10W
R622	50886610	1 PC	RMGCFMIN 10K0 OHM +5% 100M10W
R623	50886610	1 PC	RMGCFMIN 10K0 OHM +5% 100M10W
R624	50886610	1 PC	RMGCFMIN 10K0 OHM +5% 100M10W
R625	50886610	1 PC	RMGCFMIN 10K0 OHM +5% 100M10W
R626	50886610	1 PC	RMGCFMIN 10K0 OHM +5% 100M10W
R627	50886610	1 PC	RMGCFMIN 10K0 OHM +5% 100M10W
R628	50886610	1 PC	RMGCFMIN 10K0 OHM +5% 100M10W
R629	50886610	1 PC	RMGCFMIN 10K0 OHM +5% 100M10W
R632	90574370	1 PC	RMGCFMIN 82R0 OHM +5% 100M10W
R633	30944270	1 PC	RMGCFMIN 68R0 OHM +5% 100M10W
R634	50886630	1 PC	RMGCFMIN 100K0 OHM +5% 100M10W
R635	20471950	1 PC	RMGCFMIN 1K0 OHM +5% 100M10W
R636	20471950	1 PC	RMGCFMIN 1K0 OHM +5% 100M10W
R637	20471950	1 PC	RMGCFMIN 1K0 OHM +5% 100M10W
R638	80440420	1 PC	RMGCFMIN 33K0 OHM +5% 100M10W
R639	30944270	1 PC	RMGCFMIN 68R0 OHM +5% 100M10W
R641	50886630	1 PC	RMGCFMIN 100K0 OHM +5% 100M10W
R642	20471950	1 PC	RMGCFMIN 1K0 OHM +5% 100M10W
R643	11066480	1 PC	RMGCFMIN 47K0 OHM +5% 100M10W
R644	20471950	1 PC	RMGCFMIN 1K0 OHM +5% 100M10W
R651	20471950	1 PC	RMGCFMIN 1K0 OHM +5% 100M10W
R661	80440510	1 PC	RMGCFMIN 0 OHM +0% 100M10W
R662	80440510	1 PC	RMGCFMIN 0 OHM +0% 100M10W
R665	50886610	1 PC	RMGCFMIN 10K0 OHM +5% 100M10W
R666	80440430	1 PC	RMGCFMIN 43K0 OHM +5% 100M10W

Ref. Designator	Part Number	Qty	Description
R670	80440510	1 PC	RMGCFMIN 0 OHM +0% 100MIOW
R677	20471950	1 PC	RMGCFMIN 1K0 OHM +5% 100MIOW
R678	20471950	1 PC	RMGCFMIN 1K0 OHM +5% 100MIOW
R679	20471950	1 PC	RMGCFMIN 1K0 OHM +5% 100MIOW
R680	40438300	1 PC	RMGCFMIN 6K8 OHM +5% 100MIOW
R681	80440390	1 PC	RMGCFMIN 2K2 OHM +5% 100MIOW
R682	50886610	1 PC	RMGCFMIN 10K0 OHM +5% 100MIOW
R683	11066460	1 PC	RMGCFMIN 8K2 OHM +5% 100MIOW
R684	11066500	1 PC	RMGCFMIN 68K0 OHM +5% 100MIOW
R685	70434200	1 PC	RMGCFMIN 100R0 OHM +5% 100MIOW
R687	60444420	1 PC	RMGCFMIN 150K0 OHM +5% 100MIOW
R688	50886670	1 PC	RMGCFMIN 1M0 OHM +5% 100MIOW
R689	60444370	1 PC	RMGCFMIN 180R0 OHM +5% 100MIOW
R690	30944270	1 PC	RMGCFMIN 68R0 OHM +5% 100MIOW
R691	30944250	1 PC	RMGCFMIN 10R0 OHM +5% 100MIOW
R692	30944250	1 PC	RMGCFMIN 10R0 OHM +5% 100MIOW
R692	80440510	1 PC	RMGCFMIN 0 OHM +0% 100MIOW
R693	60444370	1 PC	RMGCFMIN 180R0 OHM +5% 100MIOW
R694	50886670	1 PC	RMGCFMIN 1M0 OHM +5% 100MIOW
R696	40438350	1 PC	RMGCFMIN 470K0 OHM +5% 100MIOW
R697	40438350	1 PC	RMGCFMIN 470K0 OHM +5% 100MIOW
R698	50886610	1 PC	RMGCFMIN 10K0 OHM +5% 100MIOW
R699	20471990	1 PC	RMGCFMIN 12K0 OHM +5% 100MIOW
RC601	30944250	1 PC	RMGCFMIN 10R0 OHM +5% 100MIOW
RC602	90574370	1 PC	RMGCFMIN 82R0 OHM +5% 100MIOW
RC603	30944250	1 PC	RMGCFMIN 10R0 OHM +5% 100MIOW
RC604	90574370	1 PC	RMGCFMIN 82R0 OHM +5% 100MIOW
RC606	90574370	1 PC	RMGCFMIN 82R0 OHM +5% 100MIOW
RC607	90574370	1 PC	RMGCFMIN 82R0 OHM +5% 100MIOW
RC608	30944250	1 PC	RMGCFMIN 10R0 OHM +5% 100MIOW
RC609	30944250	1 PC	RMGCFMIN 10R0 OHM +5% 100MIOW
RC610	90574370	1 PC	RMGCFMIN 82R0 OHM +5% 100MIOW
RC612	90574370	1 PC	RMGCFMIN 82R0 OHM +5% 100MIOW
RC614	30944270	1 PC	RMGCFMIN 68R0 OHM +5% 100MIOW
RF601	80440370	1 PC	RMGCFMIN 150R0 OHM +5% 100MIOW
RF601	90574370	1 PC	RMGCFMIN 82R0 OHM +5% 100MIOW
RF602	30944250	1 PC	RMGCFMIN 10R0 OHM +5% 100MIOW
RF603	80440370	1 PC	RMGCFMIN 150R0 OHM +5% 100MIOW
RF603	90574370	1 PC	RMGCFMIN 82R0 OHM +5% 100MIOW
RF604	30944250	1 PC	RMGCFMIN 10R0 OHM +5% 100MIOW
RF611	80440370	1 PC	RMGCFMIN 150R0 OHM +5% 100MIOW
RF611	90574370	1 PC	RMGCFMIN 82R0 OHM +5% 100MIOW
RF612	30944250	1 PC	RMGCFMIN 10R0 OHM +5% 100MIOW
RF615	30944260	1 PC	RMGCFMIN 22R0 OHM +5% 100MIOW
RF615	80440510	1 PC	RMGCFMIN 0 OHM +0% 100MIOW
RF616	30944260	1 PC	RMGCFMIN 22R0 OHM +5% 100MIOW
RF616	80440510	1 PC	RMGCFMIN 0 OHM +0% 100MIOW
RF617	30944260	1 PC	RMGCFMIN 22R0 OHM +5% 100MIOW
RF617	80440510	1 PC	RMGCFMIN 0 OHM +0% 100MIOW
RS602	90574370	1 PC	RMGCFMIN 82R0 OHM +5% 100MIOW
RS603	90574370	1 PC	RMGCFMIN 82R0 OHM +5% 100MIOW
RS605	90574370	1 PC	RMGCFMIN 82R0 OHM +5% 100MIOW
RS606	90574370	1 PC	RMGCFMIN 82R0 OHM +5% 100MIOW
RS608	90574370	1 PC	RMGCFMIN 82R0 OHM +5% 100MIOW
RS609	90574370	1 PC	RMGCFMIN 82R0 OHM +5% 100MIOW
RS611	90574370	1 PC	RMGCFMIN 82R0 OHM +5% 100MIOW
RS612	90574370	1 PC	RMGCFMIN 82R0 OHM +5% 100MIOW
RS620	90574370	1 PC	RMGCFMIN 82R0 OHM +5% 100MIOW
RS621	90574370	1 PC	RMGCFMIN 82R0 OHM +5% 100MIOW
RS622	90574370	1 PC	RMGCFMIN 82R0 OHM +5% 100MIOW

Ref. Designator	Part Number	Qty	Description
RS623	90574370	1 PC	RMGCFMIN 82R0 OHM +5% 100MI0W
R617	11059640	1 PC	RCF 1K0 OHM +5% 250MI0W
R619	11059640	1 PC	RCF 1K0 OHM +5% 250MI0W
R640	20469460	1 PC	RCF 2K2 OHM +5% 250MI0W
R674	11059640	1 PC	RCF 1K0 OHM +5% 250MI0W
R686	50883030	1 PC	RCF 150K0 OHM +5% 250MI0W
R695	60441550	1 PC	RCF 330R0 OHM +5% 250MI0W
<i>Miscellaneous</i>			
J025	80440510	1 PC	RMGCFMIN 0 OHM +0% 100MI0W
J031	80440510	1 PC	RMGCFMIN 0 OHM +0% 100MI0W
J032	80440510	1 PC	RMGCFMIN 0 OHM +0% 100MI0W
J033	80440510	1 PC	RMGCFMIN 0 OHM +0% 100MI0W
J040	80440510	1 PC	RMGCFMIN 0 OHM +0% 100MI0W
J045	80440510	1 PC	RMGCFMIN 0 OHM +0% 100MI0W
J058	80440510	1 PC	RMGCFMIN 0 OHM +0% 100MI0W
J063	80440510	1 PC	RMGCFMIN 0 OHM +0% 100MI0W
J065	80440510	1 PC	RMGCFMIN 0 OHM +0% 100MI0W
J066	80440510	1 PC	RMGCFMIN 0 OHM +0% 100MI0W
J067	80440510	1 PC	RMGCFMIN 0 OHM +0% 100MI0W
J072	80440510	1 PC	RMGCFMIN 0 OHM +0% 100MI0W
J073	80440510	1 PC	RMGCFMIN 0 OHM +0% 100MI0W
J074	80440510	1 PC	RMGCFMIN 0 OHM +0% 100MI0W
J076	80440510	1 PC	RMGCFMIN 0 OHM +0% 100MI0W
J077	80440510	1 PC	RMGCFMIN 0 OHM +0% 100MI0W
J079	80440510	1 PC	RMGCFMIN 0 OHM +0% 100MI0W
J081	80440510	1 PC	RMGCFMIN 0 OHM +0% 100MI0W
J083	80440510	1 PC	RMGCFMIN 0 OHM +0% 100MI0W
J086	80440510	1 PC	RMGCFMIN 0 OHM +0% 100MI0W
J089	80440510	1 PC	RMGCFMIN 0 OHM +0% 100MI0W
J090	80440510	1 PC	RMGCFMIN 0 OHM +0% 100MI0W
J091	80440510	1 PC	RMGCFMIN 0 OHM +0% 100MI0W
J099	80440510	1 PC	RMGCFMIN 0 OHM +0% 100MI0W
J101	80440510	1 PC	RMGCFMIN 0 OHM +0% 100MI0W
J116	80440510	1 PC	RMGCFMIN 0 OHM +0% 100MI0W
J121	80440510	1 PC	RMGCFMIN 0 OHM +0% 100MI0W
L601	55179350	1 PC	LF 22U0H +10% 3.4 OHM 130.0A
L602	55179350	1 PC	LF 22U0H +10% 3.4 OHM 130.0A
L603	55179350	1 PC	LF 22U0H +10% 3.4 OHM 130.0A
TBD	55179350	1 PC	LF 22U0H +10% 3.4 OHM 130.0A
TBD1	55168840	1 PC	LF 47U0H +10% 5.8 OHM 70MI0A
B601	55179500	1 PC	LFBEAD 80.582OHM 100M0HZ FB-30 HC-3580
B602	55179500	1 PC	LFBEAD 80.582OHM 100M0HZ FB-30 HC-3580
B603	55179500	1 PC	LFBEAD 80.582OHM 100M0HZ FB-30 HC-3580
CN602	55175900	1 PC	WIRECONASY UNIQUE 4P 380MM UL1007 PVC DISCRETE 26 1
CN603	55175890	1 PC	WIRECONASY UNIQUE 4P 250MM UL1007 PVC DISCRETE 26 1
CP601	55174650	1 PC	CONN 2.0MM 16 MA R NAT SOCKET MOLEX 35237-1610 0 0
CP602	55123340	1 PC	CONN 2.0MM 8 MA ST NAT LW2002P08 0 0
G001	55244390	1 PC	WIRECONASY UNIQUE 1P 100MM UL1007 PVC DISCRETE 18 1
J034	55179510	1 PC	LFBEAD 44.1653OHM 100M0HZ FB-30 HC-3550
J050	55179510	1 PC	LFBEAD 44.1653OHM 100M0HZ FB-30 HC-3550
J051	55179510	1 PC	LFBEAD 44.1653OHM 100M0HZ FB-30 HC-3550
J052	55179510	1 PC	LFBEAD 44.1653OHM 100M0HZ FB-30 HC-3550
JA601	55179510	1 PC	CON DIN SCKT MIX SOCKET RCA-118JP1S
JA602	55179510	1 PC	CON DIN SCKT MIX SOCKET RCA-118JP1S
JA603	55179510	1 PC	CON DIN SCKT MIX SOCKET RCA-118JP1S
JA604	55179510	1 PC	CON DIN SCKT MIX SOCKET RCA-118JP1S
JA605	55179510	1 PC	CON DIN SCKT MIX SOCKET RCA-118JP1S
JA606	55179510	1 PC	CON DIN SCKT MIX SOCKET RCA-118JP1S

Ref. Designator	Part Number	Qty	Description
JA607	55179510	1 PC	CON DIN SCKT MIX SOCKET RCA-118JP1S
X601	55179470	1 PC	FILQZ 14M31818 HZ +30 PPM 30K0 OHM PARALLEL 22P0 F

Processor PCB

Capacitors

C701	11058670	1 PC	CCCFMIN 100P0F +5% -5% 50.0V NP0
C702	11058670	1 PC	CCCFMIN 100P0F +5% -5% 50.0V NP0
C703	11058670	1 PC	CCCFMIN 100P0F +5% -5% 50.0V NP0
C704	11058670	1 PC	CCCFMIN 100P0F +5% -5% 50.0V NP0
C705	11058670	1 PC	CCCFMIN 100P0F +5% -5% 50.0V NP0
C706	11058670	1 PC	CCCFMIN 100P0F +5% -5% 50.0V NP0
C707	11058670	1 PC	CCCFMIN 100P0F +5% -5% 50.0V NP0
C708	11058670	1 PC	CCCFMIN 100P0F +5% -5% 50.0V NP0
C712	11058670	1 PC	CCCFMIN 100P0F +5% -5% 50.0V NP0
C713	11058670	1 PC	CCCFMIN 100P0F +5% -5% 50.0V NP0
C717	11058670	1 PC	CCCFMIN 100P0F +5% -5% 50.0V NP0
C718	11058670	1 PC	CCCFMIN 100P0F +5% -5% 50.0V NP0
C719	11058670	1 PC	CCCFMIN 100P0F +5% -5% 50.0V NP0
C720	11058670	1 PC	CCCFMIN 100P0F +5% -5% 50.0V NP0
C721	11058670	1 PC	CCCFMIN 100P0F +5% -5% 50.0V NP0
C722	11058670	1 PC	CCCFMIN 100P0F +5% -5% 50.0V NP0
C726	11058670	1 PC	CCCFMIN 100P0F +5% -5% 50.0V NP0
C727	11058670	1 PC	CCCFMIN 100P0F +5% -5% 50.0V NP0
C731	11058670	1 PC	CCCFMIN 100P0F +5% -5% 50.0V NP0
C732	11058670	1 PC	CCCFMIN 100P0F +5% -5% 50.0V NP0
C733	11058670	1 PC	CCCFMIN 100P0F +5% -5% 50.0V NP0
C734	11058670	1 PC	CCCFMIN 100P0F +5% -5% 50.0V NP0
C735	11058670	1 PC	CCCFMIN 100P0F +5% -5% 50.0V NP0
C736	11058670	1 PC	CCCFMIN 100P0F +5% -5% 50.0V NP0
C737	11058670	1 PC	CCCFMIN 100P0F +5% -5% 50.0V NP0
C738	11058670	1 PC	CCCFMIN 100P0F +5% -5% 50.0V NP0
C739	11058670	1 PC	CCCFMIN 100P0F +5% -5% 50.0V NP0
C740	11058670	1 PC	CCCFMIN 100P0F +5% -5% 50.0V NP0
C750	50882360	1 PC	CCCFMIN 33P0F +5% -5% 50.0V NP0
C755	50882360	1 PC	CCCFMIN 33P0F +5% -5% 50.0V NP0
C759	11058670	1 PC	CCCFMIN 100P0F +5% -5% 50.0V NP0
C762	11058670	1 PC	CCCFMIN 100P0F +5% -5% 50.0V NP0
C763	11058670	1 PC	CCCFMIN 100P0F +5% -5% 50.0V NP0
C767	11058670	1 PC	CCCFMIN 100P0F +5% -5% 50.0V NP0
C772	11058670	1 PC	CCCFMIN 100P0F +5% -5% 50.0V NP0
C775	11058670	1 PC	CCCFMIN 100P0F +5% -5% 50.0V NP0
C793	11059330	1 PC	CCCFMIN 2N2F +10% -10% 50.0V X7R
C794	11059330	1 PC	CCCFMIN 2N2F +10% -10% 50.0V X7R
C812	50882360	1 PC	CCCFMIN 33P0F +5% -5% 50.0V NP0
C817	50882360	1 PC	CCCFMIN 33P0F +5% -5% 50.0V NP0
C820	11058670	1 PC	CCCFMIN 100P0F +5% -5% 50.0V NP0
C824	11058670	1 PC	CCCFMIN 100P0F +5% -5% 50.0V NP0
C828	11058670	1 PC	CCCFMIN 100P0F +5% -5% 50.0V NP0
C830	50882360	1 PC	CCCFMIN 33P0F +5% -5% 50.0V NP0
C833	11058670	1 PC	CCCFMIN 100P0F +5% -5% 50.0V NP0
C835	50882360	1 PC	CCCFMIN 33P0F +5% -5% 50.0V NP0
C840	50882360	1 PC	CCCFMIN 33P0F +5% -5% 50.0V NP0
C845	50882360	1 PC	CCCFMIN 33P0F +5% -5% 50.0V NP0
C848	11058670	1 PC	CCCFMIN 100P0F +5% -5% 50.0V NP0
C850	11059330	1 PC	CCCFMIN 2N2F +10% -10% 50.0V X7R
C855	50882360	1 PC	CCCFMIN 33P0F +5% -5% 50.0V NP0
C858	80436820	1 PC	CCCFMIN 680P0F +10% -10% 50.0V X7R
C860	80436820	1 PC	CCCFMIN 680P0F +10% -10% 50.0V X7R

Ref. Designator	Part Number	Qty	Description
C863	80436820	1 PC	CCCFMIN 680P0F +10% -10% 50.0V X7R
C865	80436820	1 PC	CCCFMIN 680P0F +10% -10% 50.0V X7R
C870	11058670	1 PC	CCCFMIN 100P0F +5% -5% 50.0V NP0
C871	11058670	1 PC	CCCFMIN 100P0F +5% -5% 50.0V NP0
C709	10121000	1 PC	CE 10U0F +20% 16.0V 85C
C710	20267830	1 PC	CE 47U0F +20% 16.0V 85C
C711	10121000	1 PC	CE 10U0F +20% 16.0V 85C
C714	10121000	1 PC	CE 10U0F +20% 16.0V 85C
C715	20267830	1 PC	CE 47U0F +20% 16.0V 85C
C716	10121000	1 PC	CE 10U0F +20% 16.0V 85C
C723	10121000	1 PC	CE 10U0F +20% 16.0V 85C
C724	20267830	1 PC	CE 47U0F +20% 16.0V 85C
C725	10121000	1 PC	CE 10U0F +20% 16.0V 85C
C728	10121000	1 PC	CE 10U0F +20% 16.0V 85C
C729	20267830	1 PC	CE 47U0F +20% 16.0V 85C
C730	10121000	1 PC	CE 10U0F +20% 16.0V 85C
C741	10121000	1 PC	CE 10U0F +20% 16.0V 85C
C742	20267830	1 PC	CE 47U0F +20% 16.0V 85C
C743	10121000	1 PC	CE 10U0F +20% 16.0V 85C
C744	10121000	1 PC	CE 10U0F +20% 16.0V 85C
C745	20267830	1 PC	CE 47U0F +20% 16.0V 85C
C746	10121000	1 PC	CE 10U0F +20% 16.0V 85C
C747	10121000	1 PC	CE 10U0F +20% 16.0V 85C
C749	20267830	1 PC	CE 47U0F +20% 16.0V 85C
C751	10121000	1 PC	CE 10U0F +20% 16.0V 85C
C752	10121000	1 PC	CE 10U0F +20% 16.0V 85C
C754	20267830	1 PC	CE 47U0F +20% 16.0V 85C
C756	10121000	1 PC	CE 10U0F +20% 16.0V 85C
C757	20267830	1 PC	CE 47U0F +20% 16.0V 85C
C758	20267830	1 PC	CE 47U0F +20% 16.0V 85C
C760	20267830	1 PC	CE 47U0F +20% 16.0V 85C
C761	20267830	1 PC	CE 47U0F +20% 16.0V 85C
C764	20267830	1 PC	CE 47U0F +20% 16.0V 85C
C765	20267830	1 PC	CE 47U0F +20% 16.0V 85C
C768	20267830	1 PC	CE 47U0F +20% 16.0V 85C
C769	20267830	1 PC	CE 47U0F +20% 16.0V 85C
C770	20267830	1 PC	CE 47U0F +20% 16.0V 85C
C771	20267830	1 PC	CE 47U0F +20% 16.0V 85C
C773	20267830	1 PC	CE 47U0F +20% 16.0V 85C
C774	20267830	1 PC	CE 47U0F +20% 16.0V 85C
C782	10121000	1 PC	CE 10U0F +20% 16.0V 85C
C783	20267830	1 PC	CE 47U0F +20% 16.0V 85C
C784	10121000	1 PC	CE 10U0F +20% 16.0V 85C
C787	10121000	1 PC	CE 10U0F +20% 16.0V 85C
C788	20267830	1 PC	CE 47U0F +20% 16.0V 85C
C789	10121000	1 PC	CE 10U0F +20% 16.0V 85C
C792	10121000	1 PC	CE 10U0F +20% 16.0V 85C
C795	20267830	1 PC	CE 47U0F +20% 16.0V 85C
C796	10121000	1 PC	CE 10U0F +20% 16.0V 85C
C797	20267830	1 PC	CE 47U0F +20% 16.0V 85C
C798	20267830	1 PC	CE 47U0F +20% 16.0V 85C
C799	20267830	1 PC	CE 47U0F +20% 16.0V 85C
C800	10121000	1 PC	CE 10U0F +20% 16.0V 85C
C801	10121000	1 PC	CE 10U0F +20% 16.0V 85C
C802	10121000	1 PC	CE 10U0F +20% 16.0V 85C
C804	10121000	1 PC	CE 10U0F +20% 16.0V 85C
C805	10121000	1 PC	CE 10U0F +20% 16.0V 85C
C807	20267830	1 PC	CE 47U0F +20% 16.0V 85C
C808	10121000	1 PC	CE 10U0F +20% 16.0V 85C
C809	10121000	1 PC	CE 10U0F +20% 16.0V 85C

Ref. Designator	Part Number	Qty	Description
C811	20267830	1 PC	CE 47U0F +20% 16.0V 85C
C813	10121000	1 PC	CE 10U0F +20% 16.0V 85C
C814	10121000	1 PC	CE 10U0F +20% 16.0V 85C
C816	20267830	1 PC	CE 47U0F +20% 16.0V 85C
C818	10121000	1 PC	CE 10U0F +20% 16.0V 85C
C819	10121000	1 PC	CE 10U0F +20% 16.0V 85C
C821	20267830	1 PC	CE 47U0F +20% 16.0V 85C
C822	10121000	1 PC	CE 10U0F +20% 16.0V 85C
C823	10121000	1 PC	CE 10U0F +20% 16.0V 85C
C825	20267830	1 PC	CE 47U0F +20% 16.0V 85C
C826	10121000	1 PC	CE 10U0F +20% 16.0V 85C
C827	10121000	1 PC	CE 10U0F +20% 16.0V 85C
C829	20267830	1 PC	CE 47U0F +20% 16.0V 85C
C831	10121000	1 PC	CE 10U0F +20% 16.0V 85C
C832	10121000	1 PC	CE 10U0F +20% 16.0V 85C
C834	20267830	1 PC	CE 47U0F +20% 16.0V 85C
C836	10121000	1 PC	CE 10U0F +20% 16.0V 85C
C837	10121000	1 PC	CE 10U0F +20% 16.0V 85C
C839	20267830	1 PC	CE 47U0F +20% 16.0V 85C
C841	10121000	1 PC	CE 10U0F +20% 16.0V 85C
C842	10121000	1 PC	CE 10U0F +20% 16.0V 85C
C844	20267830	1 PC	CE 47U0F +20% 16.0V 85C
C846	10121000	1 PC	CE 10U0F +20% 16.0V 85C
C847	10121000	1 PC	CE 10U0F +20% 16.0V 85C
C849	20267830	1 PC	CE 47U0F +20% 16.0V 85C
C851	10121000	1 PC	CE 10U0F +20% 16.0V 85C
C852	10121000	1 PC	CE 10U0F +20% 16.0V 85C
C854	20267830	1 PC	CE 47U0F +20% 16.0V 85C
C856	10121000	1 PC	CE 10U0F +20% 16.0V 85C
C857	10121000	1 PC	CE 10U0F +20% 16.0V 85C
C859	20267830	1 PC	CE 47U0F +20% 16.0V 85C
C861	20269110	1 PC	CE 330U0F +20% 6.3V 85C
C862	10121000	1 PC	CE 10U0F +20% 16.0V 85C
C864	20267830	1 PC	CE 47U0F +20% 16.0V 85C
C866	20269110	1 PC	CE 330U0F +20% 6.3V 85C
C867	20267830	1 PC	CE 47U0F +20% 16.0V 85C

Semiconductors

Q732	55112030	1 PC	TR-M FET RA/TAD 2SK117Y N 300MI0W 14MIOA
IC703	55142720KV	1 PC	IC-LOWFREQ KIC9459F SOP24 TONE/VOL/BAL/MUTE
IC704	M55142710GR	1 PC	IC-SWITCH KIC9162AF ANALOG SWITCH
IC705	55142680GR	1 PC	IC-SWITCH KIC9163AF ANALOG SWITCH
IC706	55179480KV	1 PC	IC-LOWFREQ TC9482F SOP28 TONE/VOL/BAL/MUTE
IC707	55142610CG	1 PC	IC-OPERAMP NJM2068M DUAL OP
IC708	55142610CG	1 PC	IC-OPERAMP NJM2068M DUAL OP
IC709	55142610CG	1 PC	IC-OPERAMP NJM2068M DUAL OP
IC710	55142610CG	1 PC	IC-OPERAMP NJM2068M DUAL OP
IC711	55142610CG	1 PC	IC-OPERAMP NJM2068M DUAL OP
IC713	55142610CG	1 PC	IC-OPERAMP NJM2068M DUAL OP
IC714	55142610CG	1 PC	IC-OPERAMP NJM2068M DUAL OP
IC715	55142610CG	1 PC	IC-OPERAMP NJM2068M DUAL OP
IC716	55142610CG	1 PC	IC-OPERAMP NJM2068M DUAL OP
IC717	55142610CG	1 PC	IC-OPERAMP NJM2068M DUAL OP
IC718	55142610CG	1 PC	IC-OPERAMP NJM2068M DUAL OP
IC719	55164460	1 PC	IC-OPERAMP NJM4556AM DUAL OP
IC719	55164460	1 PC	IC-OPERAMP NJM4556AM DUAL OP
IC720	55142610	1 PC	IC-OPERAMP NJM2068M DUAL OP
IC721	55142610	1 PC	IC-OPERAMP NJM2068M DUAL OP
IC722	55142610	1 PC	IC-OPERAMP NJM2068M DUAL OP

Ref. Designator	Part Number	Qty	Description
Q703	55133190	1 PC	TR-SSD DTA114YKA P 10K0 OHM 47K0 OHM
Q704	55138710	1 PC	TR-SLPSWA KTD1304 N 20V 300MI0A
Q705	55138710	1 PC	TR-SLPSWA KTD1304 N 20V 300MI0A
Q706	55133190	1 PC	TR-SSD DTA114YKA P 10K0 OHM 47K0 OHM
Q707	55133190	1 PC	TR-SSD DTA114YKA P 10K0 OHM 47K0 OHM
Q708	55138710	1 PC	TR-SLPSWA KTD1304 N 20V 300MI0A
Q709	55138710	1 PC	TR-SLPSWA KTD1304 N 20V 300MI0A
Q710	55138710	1 PC	TR-SLPSWA KTD1304 N 20V 300MI0A
Q711	55138710	1 PC	TR-SLPSWA KTD1304 N 20V 300MI0A
Q712	55133190	1 PC	TR-SSD DTA114YKA P 10K0 OHM 47K0 OHM
Q713	55138710	1 PC	TR-SLPSWA KTD1304 N 20V 300MI0A
Q714	55138710	1 PC	TR-SLPSWA KTD1304 N 20V 300MI0A
Q715	55133190	1 PC	TR-SSD DTA114YKA P 10K0 OHM 47K0 OHM
Q716	55138710	1 PC	TR-SLPSWA KTD1304 N 20V 300MI0A
Q717	55138710	1 PC	TR-SLPSWA KTD1304 N 20V 300MI0A
Q718	55133190	1 PC	TR-SSD DTA114YKA P 10K0 OHM 47K0 OHM
Q719	55138710	1 PC	TR-SLPSWA KTD1304 N 20V 300MI0A
Q720	55138710	1 PC	TR-SLPSWA KTD1304 N 20V 300MI0A
Q721	55133190	1 PC	TR-SSD DTA114YKA P 10K0 OHM 47K0 OHM
Q722	55138710	1 PC	TR-SLPSWA KTD1304 N 20V 300MI0A
Q723	55138710	1 PC	TR-SLPSWA KTD1304 N 20V 300MI0A
Q724	55133190	1 PC	TR-SSD DTA114YKA P 10K0 OHM 47K0 OHM
Q725	55133190	1 PC	TR-SSD DTA114YKA P 10K0 OHM 47K0 OHM
Q727	55138710	1 PC	TR-SLPSWA KTD1304 N 20V 300MI0A
Q729	55138710	1 PC	TR-SLPSWA KTD1304 N 20V 300MI0A
Q730	55133190	1 PC	TR-SSD DTA114YKA P 10K0 OHM 47K0 OHM
Q731	55133180	1 PC	TR-SSD DTC114YKA N 10K0 OHM 47K0 OHM
Q733	55133190	1 PC	TR-SSD DTA114YKA P 10K0 OHM 47K0 OHM
Q734	55133180	1 PC	TR-SSD DTC114YKA N 10K0 OHM 47K0 OHM
Q735	55133190	1 PC	TR-SSD DTA114YKA P 10K0 OHM 47K0 OHM
Q736	55133190	1 PC	TR-SSD DTA114YKA P 10K0 OHM 47K0 OHM
IC701	55142750	1 PC	IC-SWITCH TC9273N-007 DIP28 ANALOG SWITCH
IC702	55142750	1 PC	IC-SWITCH TC9273N-007 DIP28 ANALOG SWITCH

Resistors

R701	90574400	1 PC	RMGCFMIN 470R0 OHM +5% 100MI0W
R702	40438350	1 PC	RMGCFMIN 470K0 OHM +5% 100MI0W
R703	90574400	1 PC	RMGCFMIN 470R0 OHM +5% 100MI0W
R704	40438350	1 PC	RMGCFMIN 470K0 OHM +5% 100MI0W
R705	90574400	1 PC	RMGCFMIN 470R0 OHM +5% 100MI0W
R706	40438350	1 PC	RMGCFMIN 470K0 OHM +5% 100MI0W
R707	90574400	1 PC	RMGCFMIN 470R0 OHM +5% 100MI0W
R708	40438350	1 PC	RMGCFMIN 470K0 OHM +5% 100MI0W
R709	70434200	1 PC	RMGCFMIN 100R0 OHM +5% 100MI0W
R710	90574400	1 PC	RMGCFMIN 470R0 OHM +5% 100MI0W
R711	20472020	1 PC	RMGCFMIN 180K0 OHM +5% 100MI0W
R712	50886630	1 PC	RMGCFMIN 100K0 OHM +5% 100MI0W
R713	20471950	1 PC	RMGCFMIN 1K0 OHM +5% 100MI0W
R714	90574400	1 PC	RMGCFMIN 470R0 OHM +5% 100MI0W
R715	20472020	1 PC	RMGCFMIN 180K0 OHM +5% 100MI0W
R716	50886630	1 PC	RMGCFMIN 100K0 OHM +5% 100MI0W
R717	20471950	1 PC	RMGCFMIN 1K0 OHM +5% 100MI0W
R718	70434200	1 PC	RMGCFMIN 100R0 OHM +5% 100MI0W
R719	80440390	1 PC	RMGCFMIN 2K2 OHM +5% 100MI0W
R720	80440390	1 PC	RMGCFMIN 2K2 OHM +5% 100MI0W
R721	90574400	1 PC	RMGCFMIN 470R0 OHM +5% 100MI0W
R722	40438350	1 PC	RMGCFMIN 470K0 OHM +5% 100MI0W
R723	90574400	1 PC	RMGCFMIN 470R0 OHM +5% 100MI0W
R724	40438350	1 PC	RMGCFMIN 470K0 OHM +5% 100MI0W

Ref. Designator	Part Number	Qty	Description
R725	80440390	1 PC	RMGCFMIN 2K2 OHM +5% 100MIOW
R726	80440390	1 PC	RMGCFMIN 2K2 OHM +5% 100MIOW
R727	70434200	1 PC	RMGCFMIN 100R0 OHM +5% 100MIOW
R728	90574400	1 PC	RMGCFMIN 470R0 OHM +5% 100MIOW
R729	20472020	1 PC	RMGCFMIN 180K0 OHM +5% 100MIOW
R730	50886630	1 PC	RMGCFMIN 100K0 OHM +5% 100MIOW
R731	20471950	1 PC	RMGCFMIN 1K0 OHM +5% 100MIOW
R732	90574400	1 PC	RMGCFMIN 470R0 OHM +5% 100MIOW
R733	20472020	1 PC	RMGCFMIN 180K0 OHM +5% 100MIOW
R734	50886630	1 PC	RMGCFMIN 100K0 OHM +5% 100MIOW
R735	20471950	1 PC	RMGCFMIN 1K0 OHM +5% 100MIOW
R736	70434200	1 PC	RMGCFMIN 100R0 OHM +5% 100MIOW
R737	90574400	1 PC	RMGCFMIN 470R0 OHM +5% 100MIOW
R738	40438350	1 PC	RMGCFMIN 470K0 OHM +5% 100MIOW
R739	90574400	1 PC	RMGCFMIN 470R0 OHM +5% 100MIOW
R740	40438350	1 PC	RMGCFMIN 470K0 OHM +5% 100MIOW
R741	90574400	1 PC	RMGCFMIN 470R0 OHM +5% 100MIOW
R742	40438350	1 PC	RMGCFMIN 470K0 OHM +5% 100MIOW
R743	90574400	1 PC	RMGCFMIN 470R0 OHM +5% 100MIOW
R744	40438350	1 PC	RMGCFMIN 470K0 OHM +5% 100MIOW
R745	70434200	1 PC	RMGCFMIN 100R0 OHM +5% 100MIOW
R746	90574400	1 PC	RMGCFMIN 470R0 OHM +5% 100MIOW
R747	11066480	1 PC	RMGCFMIN 47K0 OHM +5% 100MIOW
R748	50886630	1 PC	RMGCFMIN 100K0 OHM +5% 100MIOW
R749	90574400	1 PC	RMGCFMIN 470R0 OHM +5% 100MIOW
R750	11066480	1 PC	RMGCFMIN 47K0 OHM +5% 100MIOW
R751	50886630	1 PC	RMGCFMIN 100K0 OHM +5% 100MIOW
R752	70434200	1 PC	RMGCFMIN 100R0 OHM +5% 100MIOW
R753	70434200	1 PC	RMGCFMIN 100R0 OHM +5% 100MIOW
R754	90574400	1 PC	RMGCFMIN 470R0 OHM +5% 100MIOW
R756	50886630	1 PC	RMGCFMIN 100K0 OHM +5% 100MIOW
R757	20471950	1 PC	RMGCFMIN 1K0 OHM +5% 100MIOW
R758	50886600	1 PC	RMGCFMIN 5K1 OHM +5% 100MIOW
R759	50886630	1 PC	RMGCFMIN 100K0 OHM +5% 100MIOW
R760	90574400	1 PC	RMGCFMIN 470R0 OHM +5% 100MIOW
R761	50886630	1 PC	RMGCFMIN 100K0 OHM +5% 100MIOW
R762	20471950	1 PC	RMGCFMIN 1K0 OHM +5% 100MIOW
R763	50886600	1 PC	RMGCFMIN 5K1 OHM +5% 100MIOW
R764	50886630	1 PC	RMGCFMIN 100K0 OHM +5% 100MIOW
R765	70434200	1 PC	RMGCFMIN 100R0 OHM +5% 100MIOW
R766	80440390	1 PC	RMGCFMIN 2K2 OHM +5% 100MIOW
R767	80440390	1 PC	RMGCFMIN 2K2 OHM +5% 100MIOW
R768	20471950	1 PC	RMGCFMIN 1K0 OHM +5% 100MIOW
R769	20471950	1 PC	RMGCFMIN 1K0 OHM +5% 100MIOW
R781	70434200	1 PC	RMGCFMIN 100R0 OHM +5% 100MIOW
R782	70434200	1 PC	RMGCFMIN 100R0 OHM +5% 100MIOW
R783	20471950	1 PC	RMGCFMIN 1K0 OHM +5% 100MIOW
R784	20471950	1 PC	RMGCFMIN 1K0 OHM +5% 100MIOW
R785	20471950	1 PC	RMGCFMIN 1K0 OHM +5% 100MIOW
R786	20471950	1 PC	RMGCFMIN 1K0 OHM +5% 100MIOW
R787	20471950	1 PC	RMGCFMIN 1K0 OHM +5% 100MIOW
R788	20471950	1 PC	RMGCFMIN 1K0 OHM +5% 100MIOW
R789	70434200	1 PC	RMGCFMIN 100R0 OHM +5% 100MIOW
R790	70434200	1 PC	RMGCFMIN 100R0 OHM +5% 100MIOW
R791	70434200	1 PC	RMGCFMIN 100R0 OHM +5% 100MIOW
R792	70434200	1 PC	RMGCFMIN 100R0 OHM +5% 100MIOW
R793	20471950	1 PC	RMGCFMIN 1K0 OHM +5% 100MIOW
R794	20471950	1 PC	RMGCFMIN 1K0 OHM +5% 100MIOW
R795	20471950	1 PC	RMGCFMIN 1K0 OHM +5% 100MIOW
R796	20471950	1 PC	RMGCFMIN 1K0 OHM +5% 100MIOW

Ref. Designator	Part Number	Qty	Description
R797	20471950	1 PC	RMGCFMIN 1K0 OHM +5% 100MIOW
R798	20471950	1 PC	RMGCFMIN 1K0 OHM +5% 100MIOW
R799	70434200	1 PC	RMGCFMIN 100R0 OHM +5% 100MIOW
R800	70434200	1 PC	RMGCFMIN 100R0 OHM +5% 100MIOW
R801	70434200	1 PC	RMGCFMIN 100R0 OHM +5% 100MIOW
R802	70434200	1 PC	RMGCFMIN 100R0 OHM +5% 100MIOW
R803	20471950	1 PC	RMGCFMIN 1K0 OHM +5% 100MIOW
R804	20471950	1 PC	RMGCFMIN 1K0 OHM +5% 100MIOW
R805	20471950	1 PC	RMGCFMIN 1K0 OHM +5% 100MIOW
R806	70434200	1 PC	RMGCFMIN 100R0 OHM +5% 100MIOW
R807	70434200	1 PC	RMGCFMIN 100R0 OHM +5% 100MIOW
R808	20471950	1 PC	RMGCFMIN 1K0 OHM +5% 100MIOW
R809	20471950	1 PC	RMGCFMIN 1K0 OHM +5% 100MIOW
R810	20471950	1 PC	RMGCFMIN 1K0 OHM +5% 100MIOW
R811	70434200	1 PC	RMGCFMIN 100R0 OHM +5% 100MIOW
R812	90574400	1 PC	RMGCFMIN 470R0 OHM +5% 100MIOW
R813	20472020	1 PC	RMGCFMIN 180K0 OHM +5% 100MIOW
R814	50886630	1 PC	RMGCFMIN 100K0 OHM +5% 100MIOW
R815	20471950	1 PC	RMGCFMIN 1K0 OHM +5% 100MIOW
R816	90574400	1 PC	RMGCFMIN 470R0 OHM +5% 100MIOW
R817	20472020	1 PC	RMGCFMIN 180K0 OHM +5% 100MIOW
R818	50886630	1 PC	RMGCFMIN 100K0 OHM +5% 100MIOW
R819	20471950	1 PC	RMGCFMIN 1K0 OHM +5% 100MIOW
R820	70434200	1 PC	RMGCFMIN 100R0 OHM +5% 100MIOW
R821	80440390	1 PC	RMGCFMIN 2K2 OHM +5% 100MIOW
R822	80440390	1 PC	RMGCFMIN 2K2 OHM +5% 100MIOW
R823	30944340	1 PC	RMGCFMIN 27K0 OHM +5% 100MIOW
R830	11066480	1 PC	RMGCFMIN 47K0 OHM +5% 100MIOW
R831	90574400	1 PC	RMGCFMIN 470R0 OHM +5% 100MIOW
R832	50886630	1 PC	RMGCFMIN 100K0 OHM +5% 100MIOW
R833	80440390	1 PC	RMGCFMIN 2K2 OHM +5% 100MIOW
R834	80440400	1 PC	RMGCFMIN 5K6 OHM +5% 100MIOW
R835	50886630	1 PC	RMGCFMIN 100K0 OHM +5% 100MIOW
R836	70434200	1 PC	RMGCFMIN 100R0 OHM +5% 100MIOW
R837	70434200	1 PC	RMGCFMIN 100R0 OHM +5% 100MIOW
R838	80440480	1 PC	RMGCFMIN 3M3 OHM +5% 100MIOW
R839	70434200	1 PC	RMGCFMIN 100R0 OHM +5% 100MIOW
R840	70434200	1 PC	RMGCFMIN 100R0 OHM +5% 100MIOW
R841	50886630	1 PC	RMGCFMIN 100K0 OHM +5% 100MIOW
R842	20471990	1 PC	RMGCFMIN 12K0 OHM +5% 100MIOW
R843	20471990	1 PC	RMGCFMIN 12K0 OHM +5% 100MIOW
R844	20471990	1 PC	RMGCFMIN 12K0 OHM +5% 100MIOW
R845	11066440	1 PC	RMGCFMIN 3K3 OHM +5% 100MIOW
R846	11066440	1 PC	RMGCFMIN 3K3 OHM +5% 100MIOW
R847	50886630	1 PC	RMGCFMIN 100K0 OHM +5% 100MIOW
R848	20471990	1 PC	RMGCFMIN 12K0 OHM +5% 100MIOW
R849	20471990	1 PC	RMGCFMIN 12K0 OHM +5% 100MIOW
R850	20471990	1 PC	RMGCFMIN 12K0 OHM +5% 100MIOW
R851	11066440	1 PC	RMGCFMIN 3K3 OHM +5% 100MIOW
R852	11066440	1 PC	RMGCFMIN 3K3 OHM +5% 100MIOW
R853	50886630	1 PC	RMGCFMIN 100K0 OHM +5% 100MIOW
R854	80440390	1 PC	RMGCFMIN 2K2 OHM +5% 100MIOW
R855	80440390	1 PC	RMGCFMIN 2K2 OHM +5% 100MIOW
R856	80440390	1 PC	RMGCFMIN 2K2 OHM +5% 100MIOW
R857	80440390	1 PC	RMGCFMIN 2K2 OHM +5% 100MIOW
R858	80440390	1 PC	RMGCFMIN 2K2 OHM +5% 100MIOW
R859	80440390	1 PC	RMGCFMIN 2K2 OHM +5% 100MIOW
R860	30944320	1 PC	RMGCFMIN 9K1 OHM +5% 100MIOW
R861	90574430	1 PC	RMGCFMIN 18K0 OHM +5% 100MIOW
R862	90574430	1 PC	RMGCFMIN 18K0 OHM +5% 100MIOW

Ref. Designator	Part Number	Qty	Description
R863	90574430	1 PC	RMGCFMIN 18K0 OHM +5% 100MIOW
R864	20471920	1 PC	RMGCFMIN 220R0 OHM +5% 100MIOW
R865	80440390	1 PC	RMGCFMIN 2K2 OHM +5% 100MIOW
R866	80440390	1 PC	RMGCFMIN 2K2 OHM +5% 100MIOW
R867	70434200	1 PC	RMGCFMIN 100R0 OHM +5% 100MIOW
R868	70434200	1 PC	RMGCFMIN 100R0 OHM +5% 100MIOW
R869	70434200	1 PC	RMGCFMIN 100R0 OHM +5% 100MIOW
R870	70434200	1 PC	RMGCFMIN 100R0 OHM +5% 100MIOW
R871	70434200	1 PC	RMGCFMIN 100R0 OHM +5% 100MIOW
R872	70434200	1 PC	RMGCFMIN 100R0 OHM +5% 100MIOW
R873	70434200	1 PC	RMGCFMIN 100R0 OHM +5% 100MIOW
R874	70434200	1 PC	RMGCFMIN 100R0 OHM +5% 100MIOW
R875	70434200	1 PC	RMGCFMIN 100R0 OHM +5% 100MIOW
R876	70434200	1 PC	RMGCFMIN 100R0 OHM +5% 100MIOW
R878	70434200	1 PC	RMGCFMIN 100R0 OHM +5% 100MIOW
R879	70434200	1 PC	RMGCFMIN 100R0 OHM +5% 100MIOW
R880	70434200	1 PC	RMGCFMIN 100R0 OHM +5% 100MIOW
R881	70434200	1 PC	RMGCFMIN 100R0 OHM +5% 100MIOW
R882	90574400	1 PC	RMGCFMIN 470R0 OHM +5% 100MIOW
R883	20472020	1 PC	RMGCFMIN 180K0 OHM +5% 100MIOW
R884	50886630	1 PC	RMGCFMIN 100K0 OHM +5% 100MIOW
R885	90574400	1 PC	RMGCFMIN 470R0 OHM +5% 100MIOW
R886	20472020	1 PC	RMGCFMIN 180K0 OHM +5% 100MIOW
R887	50886630	1 PC	RMGCFMIN 100K0 OHM +5% 100MIOW
R888	90574400	1 PC	RMGCFMIN 470R0 OHM +5% 100MIOW
R889	20472020	1 PC	RMGCFMIN 180K0 OHM +5% 100MIOW
R890	20471950	1 PC	RMGCFMIN 1K0 OHM +5% 100MIOW
R891	80440400	1 PC	RMGCFMIN 5K6 OHM +5% 100MIOW
R892	50886630	1 PC	RMGCFMIN 100K0 OHM +5% 100MIOW
R893	90574400	1 PC	RMGCFMIN 470R0 OHM +5% 100MIOW
R894	20472020	1 PC	RMGCFMIN 180K0 OHM +5% 100MIOW
R895	20471950	1 PC	RMGCFMIN 1K0 OHM +5% 100MIOW
R896	80440400	1 PC	RMGCFMIN 5K6 OHM +5% 100MIOW
R897	50886630	1 PC	RMGCFMIN 100K0 OHM +5% 100MIOW
R898	90574400	1 PC	RMGCFMIN 470R0 OHM +5% 100MIOW
R899	50886630	1 PC	RMGCFMIN 100K0 OHM +5% 100MIOW
R901	80440400	1 PC	RMGCFMIN 5K6 OHM +5% 100MIOW
R902	50886630	1 PC	RMGCFMIN 100K0 OHM +5% 100MIOW
R903	20471950	1 PC	RMGCFMIN 1K0 OHM +5% 100MIOW
R904	90574400	1 PC	RMGCFMIN 470R0 OHM +5% 100MIOW
R905	50886630	1 PC	RMGCFMIN 100K0 OHM +5% 100MIOW
R907	80440400	1 PC	RMGCFMIN 5K6 OHM +5% 100MIOW
R908	50886630	1 PC	RMGCFMIN 100K0 OHM +5% 100MIOW
R909	20471950	1 PC	RMGCFMIN 1K0 OHM +5% 100MIOW
R910	90574400	1 PC	RMGCFMIN 470R0 OHM +5% 100MIOW
R911	50886630	1 PC	RMGCFMIN 100K0 OHM +5% 100MIOW
R912	20471950	1 PC	RMGCFMIN 1K0 OHM +5% 100MIOW
R913	80440400	1 PC	RMGCFMIN 5K6 OHM +5% 100MIOW
R914	50886630	1 PC	RMGCFMIN 100K0 OHM +5% 100MIOW
R915	20471950	1 PC	RMGCFMIN 1K0 OHM +5% 100MIOW
R916	90574400	1 PC	RMGCFMIN 470R0 OHM +5% 100MIOW
R917	50886630	1 PC	RMGCFMIN 100K0 OHM +5% 100MIOW
R918	20471950	1 PC	RMGCFMIN 1K0 OHM +5% 100MIOW
R919	50886610	1 PC	RMGCFMIN 10K0 OHM +5% 100MIOW
R920	50886630	1 PC	RMGCFMIN 100K0 OHM +5% 100MIOW
R921	20471950	1 PC	RMGCFMIN 1K0 OHM +5% 100MIOW
R922	90574400	1 PC	RMGCFMIN 470R0 OHM +5% 100MIOW
R923	50886630	1 PC	RMGCFMIN 100K0 OHM +5% 100MIOW
R924	20471950	1 PC	RMGCFMIN 1K0 OHM +5% 100MIOW
R925	80440400	1 PC	RMGCFMIN 5K6 OHM +5% 100MIOW

Ref. Designator	Part Number	Qty	Description
R926	50886630	1 PC	RMGCFMIN 100K0 OHM +5% 100MIOW
R927	20471950	1 PC	RMGCFMIN 1K0 OHM +5% 100MIOW
R928	90574400	1 PC	RMGCFMIN 470R0 OHM +5% 100MIOW
R929	50886630	1 PC	RMGCFMIN 100K0 OHM +5% 100MIOW
R930	20471950	1 PC	RMGCFMIN 1K0 OHM +5% 100MIOW
R931	20471960	1 PC	RMGCFMIN 1K8 OHM +5% 100MIOW
R932	50886630	1 PC	RMGCFMIN 100K0 OHM +5% 100MIOW
R933	20471920	1 PC	RMGCFMIN 220R0 OHM +5% 100MIOW
R934	90574400	1 PC	RMGCFMIN 470R0 OHM +5% 100MIOW
R935	30944340	1 PC	RMGCFMIN 27K0 OHM +5% 100MIOW
R936	50886630	1 PC	RMGCFMIN 100K0 OHM +5% 100MIOW
R937	20471950	1 PC	RMGCFMIN 1K0 OHM +5% 100MIOW
R938	20471960	1 PC	RMGCFMIN 1K8 OHM +5% 100MIOW
R939	50886630	1 PC	RMGCFMIN 100K0 OHM +5% 100MIOW
R940	20471920	1 PC	RMGCFMIN 220R0 OHM +5% 100MIOW
R941	30944320	1 PC	RMGCFMIN 9K1 OHM +5% 100MIOW
R942	90574400	1 PC	RMGCFMIN 470R0 OHM +5% 100MIOW
R943	20472020	1 PC	RMGCFMIN 180K0 OHM +5% 100MIOW
R944	50886630	1 PC	RMGCFMIN 100K0 OHM +5% 100MIOW
R945	90574400	1 PC	RMGCFMIN 470R0 OHM +5% 100MIOW
R946	20472020	1 PC	RMGCFMIN 180K0 OHM +5% 100MIOW
R947	50886630	1 PC	RMGCFMIN 100K0 OHM +5% 100MIOW
R948	30944340	1 PC	RMGCFMIN 27K0 OHM +5% 100MIOW
R949	20471920	1 PC	RMGCFMIN 220R0 OHM +5% 100MIOW
R950	90574400	1 PC	RMGCFMIN 470R0 OHM +5% 100MIOW
R951	20471950	1 PC	RMGCFMIN 1K0 OHM +5% 100MIOW
R952	20471950	1 PC	RMGCFMIN 1K0 OHM +5% 100MIOW
R953	50886630	1 PC	RMGCFMIN 100K0 OHM +5% 100MIOW
R954	80440400	1 PC	RMGCFMIN 5K6 OHM +5% 100MIOW
R955	50886630	1 PC	RMGCFMIN 100K0 OHM +5% 100MIOW
R956	90574430	1 PC	RMGCFMIN 18K0 OHM +5% 100MIOW
R957	20471950	1 PC	RMGCFMIN 1K0 OHM +5% 100MIOW
R958	20471950	1 PC	RMGCFMIN 1K0 OHM +5% 100MIOW
R959	20471950	1 PC	RMGCFMIN 1K0 OHM +5% 100MIOW
R960	20471950	1 PC	RMGCFMIN 1K0 OHM +5% 100MIOW
R961	20471950	1 PC	RMGCFMIN 1K0 OHM +5% 100MIOW
R962	20471950	1 PC	RMGCFMIN 1K0 OHM +5% 100MIOW
R963	50886550	1 PC	RMGCFMIN 560R0 OHM +5% 100MIOW
R964	50886550	1 PC	RMGCFMIN 560R0 OHM +5% 100MIOW
R965	90574400	1 PC	RMGCFMIN 470R0 OHM +5% 100MIOW
R966	90574400	1 PC	RMGCFMIN 470R0 OHM +5% 100MIOW
R967	30944340	1 PC	RMGCFMIN 27K0 OHM +5% 100MIOW
R968	30944340	1 PC	RMGCFMIN 27K0 OHM +5% 100MIOW
R969	90574430	1 PC	RMGCFMIN 18K0 OHM +5% 100MIOW
R970	90574430	1 PC	RMGCFMIN 18K0 OHM +5% 100MIOW

Miscellaneous

CN408	55125070	1 PC	CONN 2.0MM 15 MA R NAT MOLEX 35237-1510 0 0
CN409	55125070	1 PC	CONN 2.0MM 15 MA R NAT MOLEX 35237-1510 0 0
CN410	55125070	1 PC	CONN 2.0MM 15 MA R NAT MOLEX 35237-1510 0 0
CN411	55125070	1 PC	CONN 2.0MM 15 MA R NAT MOLEX 35237-1510 0 0
CP205	55123310	1 PC	CONN 2.0MM 4 MA ST NAT LW2002P04 0 0
CP206	55090050	1 PC	CONN 2.0MM 10 MA ST NAT LW2002P10 0 0
CP403	55090080	1 PC	CONN 2.0MM 3 MA ST NAT LW2002P03 0 0
CP404	55090060	1 PC	CONN 2.0MM 7 MA ST NAT LW2002P07 0 0
CP405	55090100	1 PC	CONN 2.0MM 12 MA ST NAT LW2002P12 0 0
JK701	55088230	1 PC	CON PHONO SCKT RCA-606P 6 PINS
JK702	55176330	1 PC	CON PHONO SCKT RCA 4P JW4104RS GND

Ref. Designator	Part Number	Qty	Description
JK703	55176330	1 PC	CON PHONO SCKT RCA 4P JW4104RS GND

THE AVR320 TUNER IS A NON-SERVICEABLE MODULE - PART#55177300XX

SONY**CXP82832/82840/82852/82860****CMOS 8-bit Single Chip Microcomputer****Description**

The CXP82832/82840/82852/82860 is a CMOS 8-bit single chip microcomputer integrating on a single chip an A/D converter, serial interface, timer/counter, time base timer, capture timer/counter, fluorescent display panel controller/driver, remote control reception circuit, and PWM output besides the basic configurations of 8-bit CPU, ROM, RAM, and I/O port.

The CXP82832/82840/82852/82860 also provides sleep/stop function that enables lower power consumption.

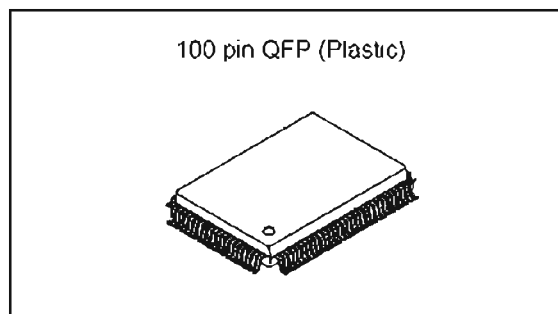
**Structure**

Silicon gate CMOS IC

Features

- Wide-range instruction system (213 instructions) to cover various types of data
 - 16-bit arithmetic/multiplication and division/boolean bit operation instructions
- Minimum instruction cycle
 - 400ns at 10MHz operation
 - (122μs at 32kHz operation)
- Incorporated ROM capacity
 - 32K bytes (CXP82832)
 - 40K bytes (CXP82840)
 - 52K bytes (CXP82852)
 - 60K bytes (CXP82860)
- Incorporated RAM capacity
 - 1536 bytes (including fluorescent display area)
- Peripheral functions
 - A/D converter
 - 8 bits, 8 channels, successive approximation method
 - (Conversion time of 32μs/10MHz)
 - Serial interface
 - 8-bit, 8-stage FIFO incorporated
 - (Auto transfer for 1 to 8 bytes), 1 channel
 - 8-bit clock synchronized type, 1 channel
 - Timers
 - 8-bit timer, 8-bit timer/counter, 19-bit time base timer
 - 16-bit capture timer/counter, 32kHz timer/counter
 - Fluorescent display panel controller/driver
 - Supports the universal grid fluorescent display panel.
 - High voltage drive output port of 56 pins (40V)
 - Maximum of 640 segments display possible
 - Display timing number of 1 to 20
 - Dimmer function
 - Incorporated pull-down resistor (Mask option)
 - Hardware key scan function (Maximum of 16 × 8 key matrix supportable)
 - Remote control reception circuit
 - 8-bit pulse measurement counter, 6-stage FIFO
 - PWM output
 - 14 bits, 1 channel
- Interruption
 - 16 factors, 15 vectors, multi-interruption possible
- Standby mode
 - SLEEP/STOP
- Package
 - 100-pin plastic QFP
- Piggyback/evaluation chip
 - CXP82800 100-pin ceramic QFP

Sony reserves the right to change products and specifications without prior notice. This information does not convey any license by any implication or otherwise under any patents or other right. Application circuits shown, if any, are typical examples illustrating the operation of the devices. Sony cannot assume responsibility for any problems arising out of the use of these circuits.

Block Diagram



CXP82832/82840/82852/82860

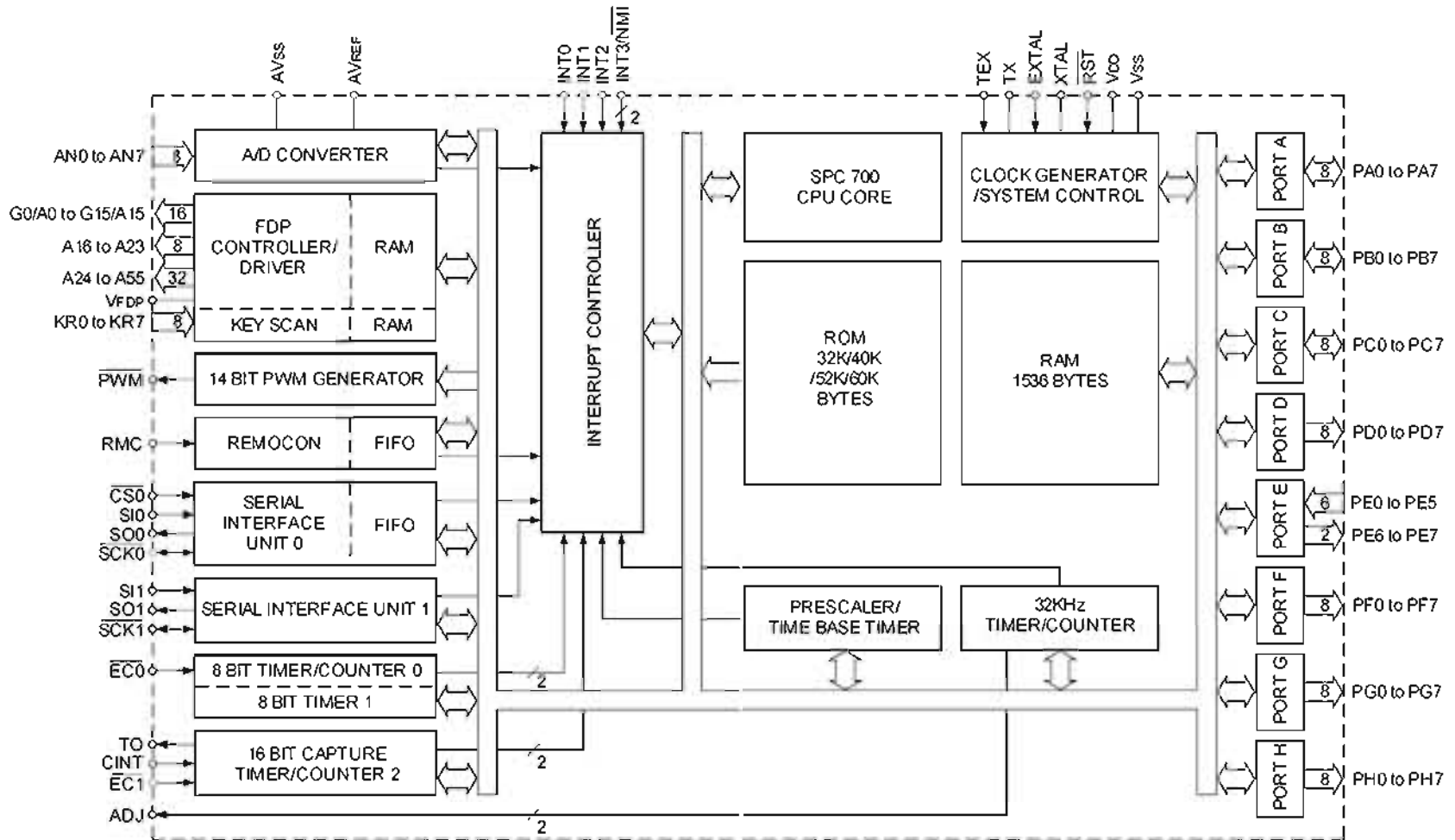

CMOS 8-Bit Single Chip Microcomputer IC

CXP82860

SONY

CXP82832/82840/82852/82860

Pin Assignment (Top View)

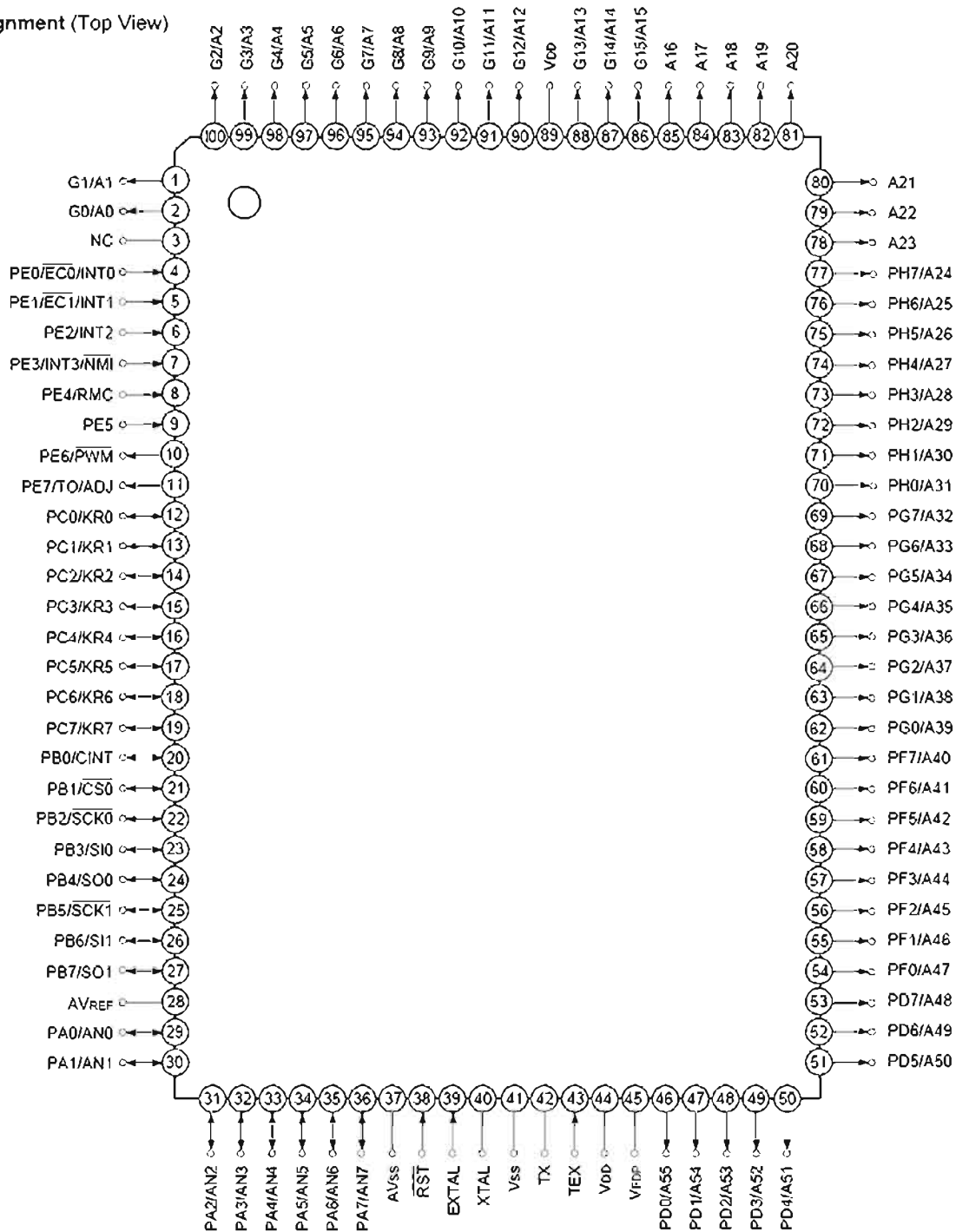

Note) 1. NC (Pin 3) must be connected to V_{DD}.

2. V_{DD} (Pins 44 and 89) must be connected to V_{DD}.

Pin code	I/O	Functions		
PA0/AN0 to PA7/AN7	I/O/ Analog input	(Port A) 8-bit I/O port. I/O can be set in a unit of single bits. Incorporation of the pull-up resistor can be set through the software in a unit of 4 bits. (8pins)	Analog inputs to A/D converter. (8 pins)	
PB0/CINT	I/O/Input	(Port B) 8-bit I/O port. I/O can be set in a unit of single bits. Incorporation of the pull-up resistor can be set through the software in a unit of 4 bits. (8 pins)	Capture input to 16-bit timer/counter.	
PB1/ $\overline{CS0}$	I/O/Input		Chip select input for serial interface (CH0).	
PB2/ $\overline{SCK0}$	I/O/I/O		Serial clock I/O (CH0).	
PB3/SI0	I/O/Input		Serial data input (CH0).	
PB4/SO0	I/O/Output		Serial data output (CH0).	
PB5/ $\overline{SCK1}$	I/O/I/O		Serial clock I/O (CH1).	
PB6/SI1	I/O/Input		Serial data input (CH1).	
PB7/SO1	I/O/Output		Serial data output (CH1).	
PC0/KR0 to PC7/KR7	I/O/Input	(Port C) 8-bit I/O port. I/O can be set in a unit of single bits. Can drive 12mA sync current. Incorporation of the pull-up resistor can be set through the software in a unit of 4 bits. (8 pins)	Serves as key return inputs when operating key scan with fluorescent display panel (FDP) segment signal. (8 pins)	
PD0/A55 to PD7/A48	Output/Output	(Port D) 8-bit output port. (8 pins)	FDP segment signal (anode connection) outputs.	
PE0/INT0/ $\overline{EC0}$	Input/Input/Input	(Port E) 8-bit port. Lower 6 bits are for inputs; upper 2 bits are for outputs. (8 pins)	Inputs for external interruption request. (4 pins)	External event inputs for timer/counter. (2 pins)
PE1/INT1/ $\overline{EC1}$	Input/Input/Input			
PE2/INT2	Input/Input		Non-maskable interruption request input.	
PE3/INT3/ NMI	Input/Input/Input			
PE4/RMC	Input/Input		Remote control reception circuit input.	
PE5	Input			
PE6/ \overline{PWM}	Output/Output		14-bit PWM output.	
PE7/TO/ADJ	Output/Output/ Output		Output for the 16-bit timer/counter rectangular waves, and 32kHz oscillation frequency division.	
PF0/A47 to PF7/A40	Output/Output	(Port F) 8-bit output port. (8pins)	FDP segment signal (anode connection) outputs.	

Pin code	I/O	Functions	
PG0/A39 to PG7/A32	Output/Output	(Port G) 8-bit output port. (8 pins)	FDP segment signal (anode connection) outputs. (8 pins)
PH0/A31 to PH7/A24	Output/Output	(Port H) 8-bit output port. (8 pins)	FDP segment signal (anode connection) outputs. (8 pins)
A16 to A23	Output	FDP segment signal (anode connection) outputs. (8 pins)	
G0/A0 to G15/A15	Output/Output	Outputs for FDP timing signals (grid connection)/segment signals (anode connection). (16 pins)	
V _{FDP}		FDP voltage supply when incorporated pull-down (PD) resistor is set by mask option.	
EXTAL	Input	Crystal connectors for system clock oscillation. When the clock is supplied externally, input to EXTAL; opposite phase clock should be input to XTAL.	
XTAL	Output		
TEX	Input	Crystal connectors for 32kHz timer/counter clock oscillation. For usage as event input, input to TEX, and open TX.	
TX	Output		
$\overline{\text{RST}}$	Input	Low-level active, system reset	
NC		NC. Under normal operation, connect to V _{DD} .	
AV _{REF}	Input	Reference voltage input for A/D converter.	
AV _{SS}		A/D converter GND.	
V _{DD}		V _{CC} supply.	
V _{SS}		GND.	

SONY**CXP82532/82540****CMOS 8-bit Single Chip Microcomputer****Description**

The CXP82532/82540 microcomputer is composed of a CPU, ROM RAM, and I/O ports. These chips feature many other high-performance circuits in a single-chip CMOS design, including an A/D converter, serial interface, timer/counter, time-base timer, capture timer/counter, fluorescent display controller/driver, remote control receiver.

This device also includes a power-on reset function and sleep/stop functions which can be used to achieve low power consumption.

80 pin QFP (Plastic)

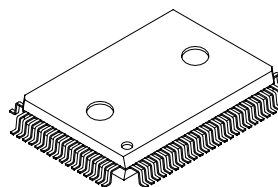
**Features**

- Instruction set which supports a wide array of data types
 - 213 types of instructions which include 16-bit calculations, multiplication and division arithmetic, and boolean bit operations.
- Minimum instruction cycle 400ns for 10MHz operation
- On-chip ROM 32K bytes (CXP82532)
 40K bytes (CXP82540)
- On-chip RAM 1120 bytes (Including fluorescent display data area)
- Peripheral functions:
 - A/D converter 8-bit, 8-channel, successive approximation system
(conversion time 32 μ s/10MHz)
 - Serial interface On-chip 8-bit, 8-stage FIFO (1 to 8 bytes auto transfer) 1 channel
8-bit clock synchronized 1 channel
 - Timers 8-bit timer
8-bit timer/counter
19-bit time-base timer
16-bit capture timer/counter
 - Fluorescent display controller/driver Maximum of 336 segment display available
1 to 16 digits dynamic display
Dimmer function
High voltage tolerance output (40V)
On-chip pull-down resistor (Mask option)
 - Remote control receiver circuit
 - On-chip noise elimination circuit
 - On-chip 6 stage FIFO 8-bit pulse measurement counter
- Interrupts 14 factors, 15 vectors multi-interruption possible
- Standby mode Sleep/stop
- Package 80-pin plastic QFP
- Piggyback/evaluator CXP82500 80-pin ceramic QFP

Structure

Silicon gate CMOS IC

Sony reserves the right to change products and specifications without prior notice. This information does not convey any license by any implication or otherwise under any patents or other right. Application circuits shown, if any, are typical examples illustrating the operation of the devices. Sony cannot assume responsibility for any problems arising out of the use of these circuits.

Block Diagram

SONY

CXP82532/82540

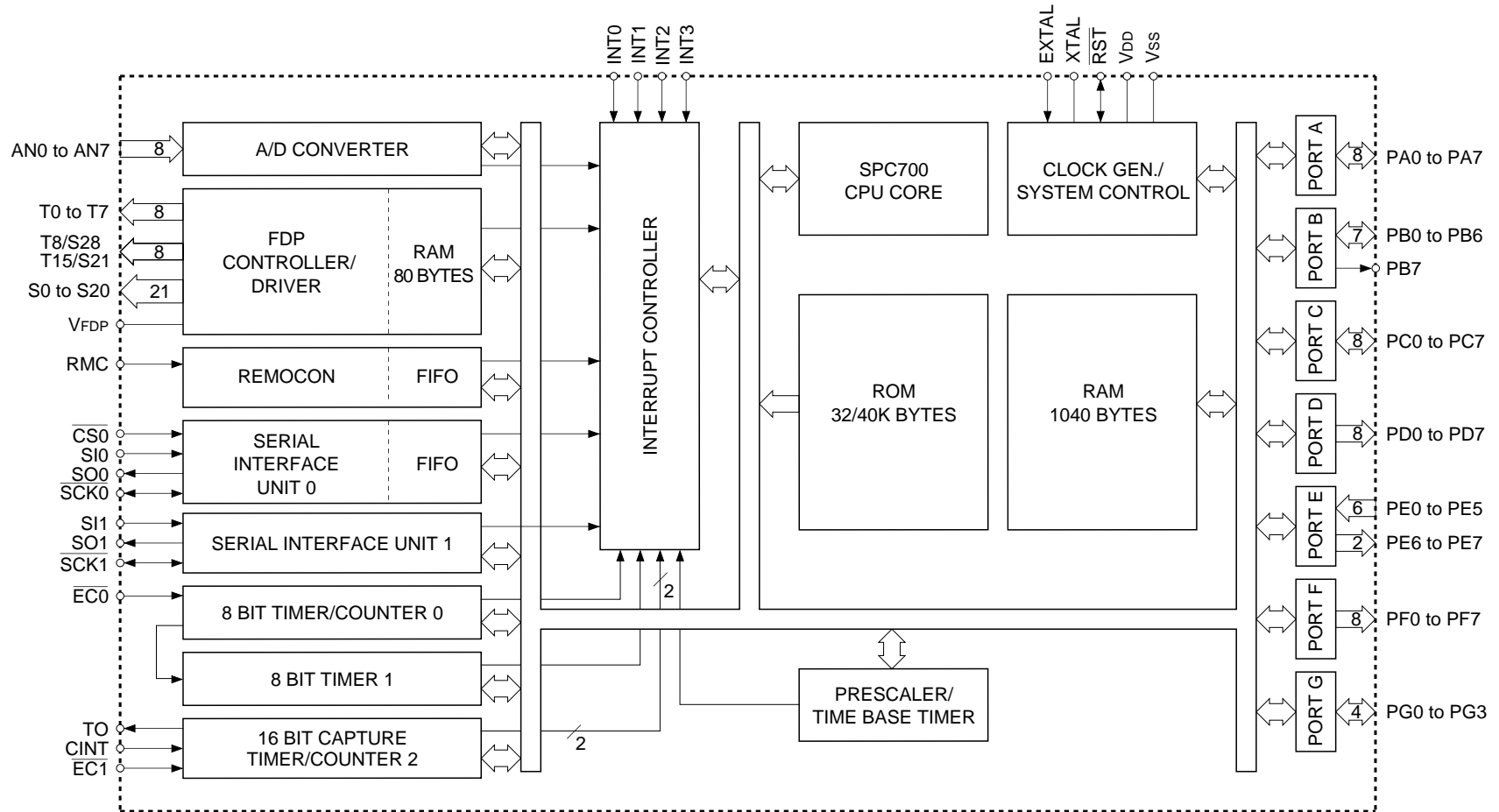

Pin Assignment (Top View)

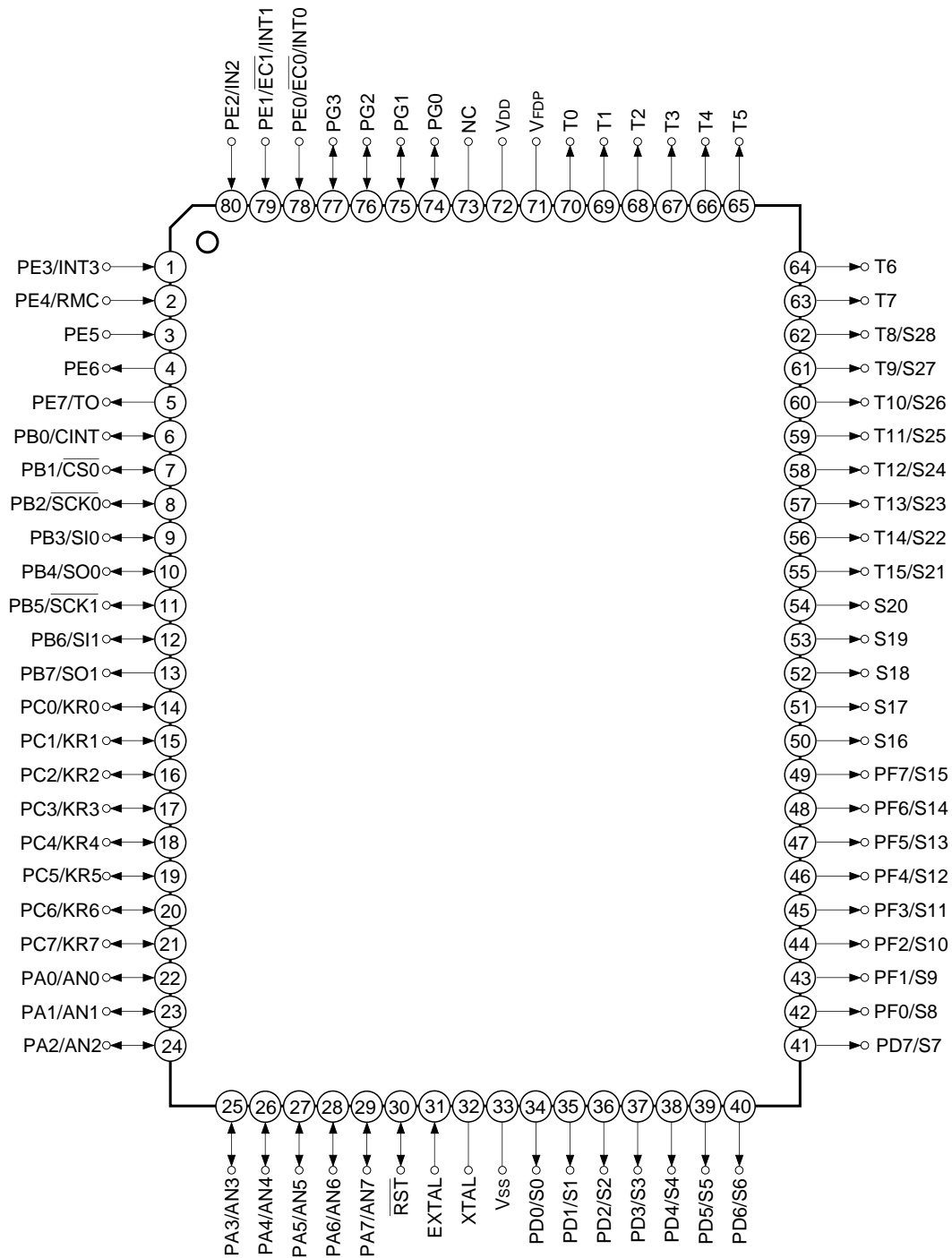

Note) NC (Pin 73) is always connected to VDD.

Pin Description

Symbol	I/O	Description	
PA0/AN0 to PA7/AN7	I/O/Analog input	(Port A) 8-bit port; single bit addressable. (8 pins)	Analog input to A/D converter. (8 pins)
PB0/CINT	I/O/Input	(Port B) Single bit addressable from amongst lower 7 bits; highest bit (PB7) dedicated to output. (8 pins)	External capture input for 16-bit timer/counter.
PB1/ $\overline{\text{CS}}_0$	I/O/Input		Chip select input for serial interface (CH0).
PB2/ $\overline{\text{SCK}}_0$	I/O/I/O		Serial clock (CH0) input/output.
PB3/SI0	I/O/Input		Serial data (CH0) input.
PB4/SO0	I/O/Output		Serial data (CH0) output.
PB5/ $\overline{\text{SCK}}_1$	I/O/I/O		Serial clock (CH1) input/output.
PB6/SI1	I/O/Input		Serial data (CH1) input.
PB7/SO1	Output/Output		Serial data (CH1) output.
PC0/KR0 to PC7/KR7	I/O/Input		(Port C) 8-bit port; single bit addressable. Can provide 12mA sink current. (8 pins)
PE0/INT0/ $\overline{\text{EC}}_0$	Input/Input/Input	(Port E) 8-bit port with lower 6 bits dedicated to input and upper 2 bits dedicated to output. (8 pins)	Input for external interrupt requests. (4 pins)
PE1/INT1/ $\overline{\text{EC}}_1$	Input/Input/Input		
PE2/INT2	Input/Input		Input for remote control receiver circuit.
PE3/INT3	Input/Input		
PE4/RMC	Input/Input		Output pin for 16-bit timer/counter rectangular waveform.
PE5	Input		
PE6	Output		
PE7/TO	Output/Output		
PG0 to PG3	I/O	(Port G) 4-bit input/output port; single bit addressable. (4 pins)	
PF0/S8 to PF7/S15	Output/Output	(Port F) 8-bit dedicated output port. (8 pins)	Segment signal output for FDP.
S16 to S20	Output	Segment signal output for FDP.	
T8/S28 to T15/S21	Output/Output	Dual purpose output for FDP timing and segment signals.	
T0 to T7	Output	Timing signal output for FDP.	
PD0/S0 to PD7/S7	Output/Output	(Port D) 8-bit dedicated output port. (8 pins)	Segment signal output for FDP.

Symbol	I/O	Description
V _{FDP}		Provides voltage for FDP when on-chip resistor is selected under mask option.
EXTAL	Input	Connection for system clock oscillation crystal. When using an external clock, input normal signal to EXTAL and reverse phase signal to the XTAL pin.
XTAL	Output	
$\overline{\text{RST}}$	I/O	System reset, active "L". The $\overline{\text{RST}}$ pin is an input/output pin which outputs a "L" level from the on-chip power-on reset circuit when the power is turned on. (Mask option)
NC		NC pin is always connected to V _{DD} .
V _{DD}		Positive power supply pin.
V _{SS}		GND

74VHC153MX

Dual 4-Input Multiplexer

Pin Descriptions

Pin Names	Description
I _{0a} -I _{3a}	Side A Data Inputs
I _{0b} -I _{3b}	Side B Data Inputs
S ₀ , S ₁	Common Select Inputs
\bar{E}_a	Side A Enable Input
\bar{E}_b	Side B Enable Input
Z _a	Side A Output
Z _b	Side B Output

Connection Diagram

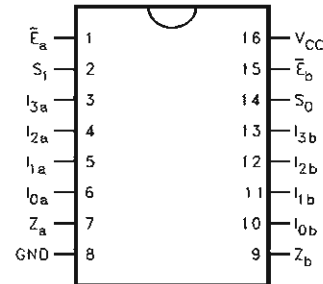

Functional Description

The VHC153 is a dual 4-input multiplexer. It can select two bits of data from up to four sources under the control of the common Select inputs (S₀, S₁). The two 4-input multiplexer circuits have individual active-LOW Enables (\bar{E}_a , \bar{E}_b) which can be used to strobe the outputs independently. When the Enables (\bar{E}_a , \bar{E}_b) are HIGH, the corresponding outputs (Z_a, Z_b) are forced LOW. The VHC153 is the logic implementation of a 2-pole, 4-position switch, where the position of the switch is determined by the logic levels supplied to the Select inputs. The logic equations for the outputs are shown below.

$$Z_a = \bar{E}_a \cdot (I_{0a} \cdot \bar{S}_1 \cdot \bar{S}_0 + I_{1a} \cdot \bar{S}_1 \cdot S_0 + I_{2a} \cdot S_1 \cdot \bar{S}_0 + I_{3a} \cdot S_1 \cdot S_0)$$

$$Z_b = \bar{E}_b \cdot (I_{0b} \cdot \bar{S}_1 \cdot \bar{S}_0 + I_{1b} \cdot \bar{S}_1 \cdot S_0 + I_{2b} \cdot S_1 \cdot \bar{S}_0 + I_{3b} \cdot S_1 \cdot S_0)$$

Truth Table

Select Inputs		Inputs (a or b)					Output
S ₀	S ₁	\bar{E}	I ₀	I ₁	I ₂	I ₃	Z
X	X	H	X	X	X	X	L
L	L	L	L	X	X	X	L
L	L	L	H	X	X	X	H
H	L	L	X	L	X	X	L
H	L	L	X	H	X	X	H
L	H	L	X	X	L	X	L
L	H	L	X	X	H	X	H
H	H	L	X	X	X	L	L
H	H	L	X	X	X	H	H

H = HIGH Voltage Level
 L = LOW Voltage Level
 X = Immaterial

Logic Diagram

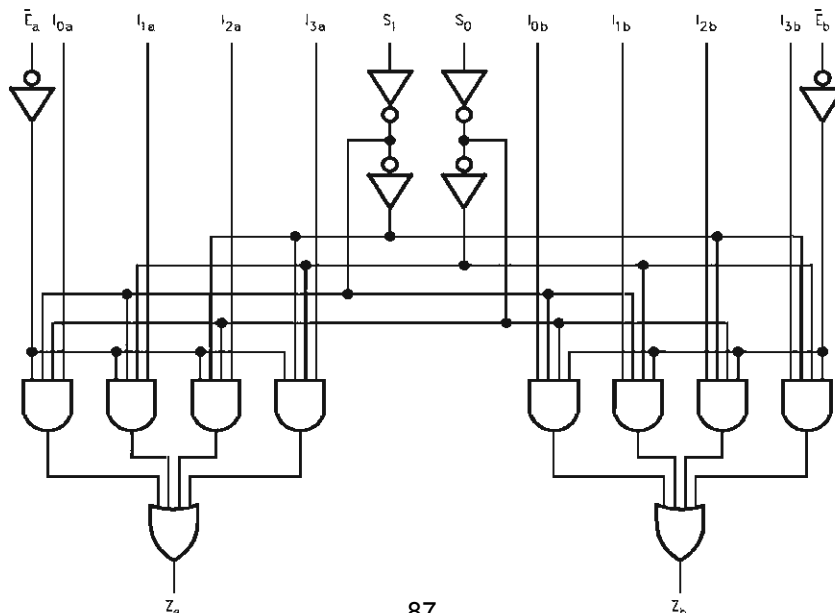

74VHC157MX

Quad 2-Input Multiplexer

Pin Configuration

Pin Names	Description
I _{0a} -I _{0d}	Source 0 Data Inputs
I _{1a} -I _{1d}	Source 1 Data Inputs
\bar{E}	Enable Input
S	Select Input
Z _a -Z _d	Outputs

Connection Diagram

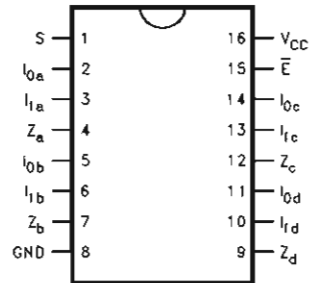

Truth Table

Inputs				Outputs
\bar{E}	S	I ₀	I ₁	Z
H	X	X	X	L
L	H	X	L	L
L	H	X	H	H
L	L	L	X	L
L	L	H	X	H

H = HIGH Voltage Level
 L = LOW Voltage Level
 X = Immaterial

Functional Description

The VHC157 is a quad 2-input multiplexer. It selects four bits of data from two sources under the control of a common Select input (S). The Enable input (\bar{E}) is active-LOW. When \bar{E} is HIGH, all of the outputs (Z) are forced LOW regardless of all other inputs. The VHC157 is the logic implementation of a 4-pole, 2-position switch where the position of the switch is determined by the logic levels supplied to the Select input. The logic equations for the outputs are shown below:

$$Z_a = \bar{E} \cdot (I_{1a} \cdot S + I_{0a} \cdot \bar{S})$$

$$Z_b = \bar{E} \cdot (I_{1b} \cdot S + I_{0b} \cdot \bar{S})$$

$$Z_c = \bar{E} \cdot (I_{1c} \cdot S + I_{0c} \cdot \bar{S})$$

$$Z_d = \bar{E} \cdot (I_{1d} \cdot S + I_{0d} \cdot \bar{S})$$

A common use of the VHC157 is the moving of data from two groups of registers to four common output busses. The particular register from which the data comes is determined by the state of the Select input. A less obvious use is as a function generator. The VHC157 can generate any four of the sixteen different functions of two variables with one variable common. This is useful for implementing gating functions.

Logic Diagram

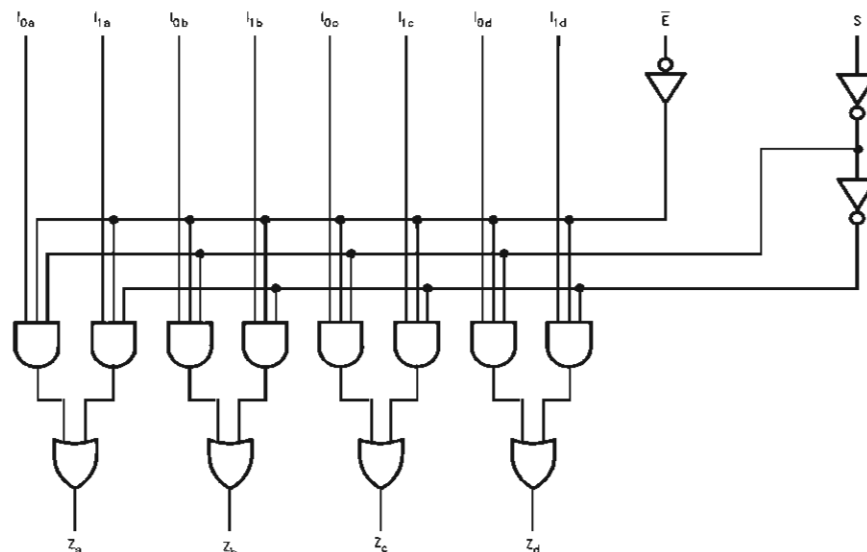

Please note that this diagram is provided only for the understanding of logic operations and should not be used to estimate propagation delays.

74VHC574

OCTAL D-TYPE FLIP FLOP WITH 3 STATE OUTPUTS NON INVERTING

- HIGH SPEED:
- $f_{MAX} = 180$ MHz (TYP.) at $V_{CC} = 5$ V
- LOW POWER DISSIPATION:
 $I_{CC} = 4$ μ A (MAX.) at $T_A = 25^\circ$ C
- HIGH NOISE IMMUNITY:
 $V_{NIH} = V_{NIL} = 28\%$ V_{CC} (MIN.)
- POWER DOWN PROTECTION ON INPUTS
- SYMMETRICAL OUTPUT IMPEDANCE:
 $|I_{OH}| = |I_{OL}| = 8$ mA (MIN)
- BALANCED PROPAGATION DELAYS:
 $t_{PLH} \approx t_{PHL}$
- OPERATING VOLTAGE RANGE:
 $V_{CC(OPR)} = 2$ V to 5.5 V
- PIN AND FUNCTION COMPATIBLE WITH 74 SERIES 574
- IMPROVED LATCH-UP IMMUNITY
- LOW NOISE: $V_{OLP} = 0.9$ V (MAX.)

DESCRIPTION

The 74VHC574 is an advanced high-speed CMOS OCTAL D-TYPE FLIP FLOP with 3 STATE OUTPUTS NON INVERTING fabricated with sub-micron silicon gate and double-layer metal wiring C²MOS technology.

These 8 bit D-Type flip-flop is controlled by a clock input (CK) and an output enable input (\overline{OE}).

On the positive transition of the clock, the Q outputs will be set to the logic states that were setup at the D inputs.

While the (\overline{OE}) input is low, the 8 outputs will be in a normal logic state (high or low logic level) and

PIN CONNECTION AND IEC LOGIC SYMBOLS

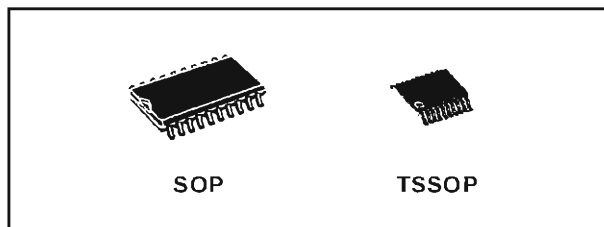
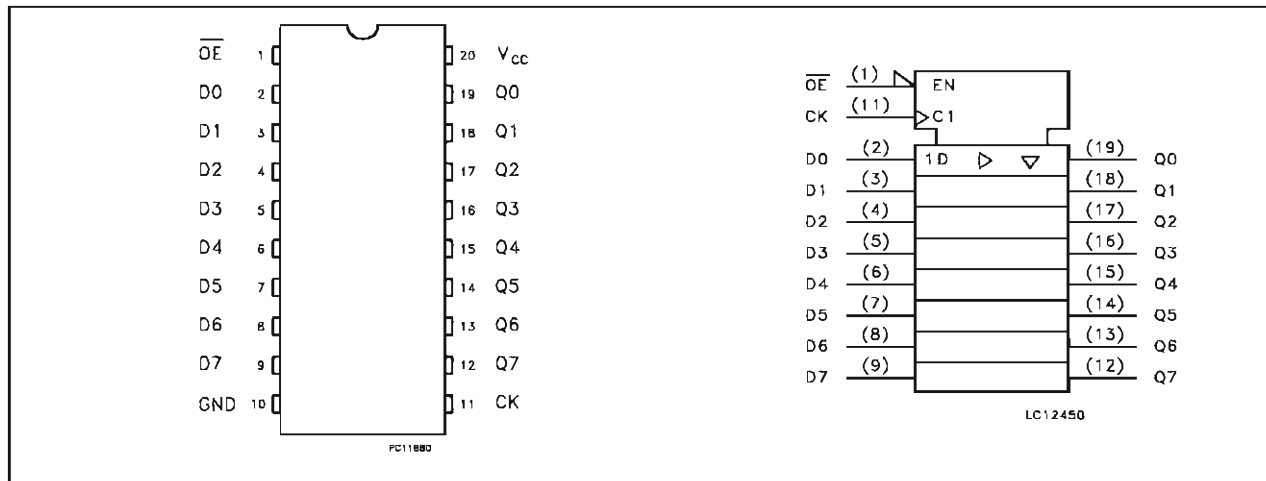

ORDER CODES

PACKAGE	TUBE	T & R
SOP	74VHC574M	74VHC574MTR
TSSOP		74VHC574TTR

while high level the outputs will be in a high impedance state.

The Output control does not affect the internal operation of flip flop; that is, the old data can be retained or the new data can be entered even while the outputs are off.

Power down protection is provided on all inputs and 0 to 7V can be accepted on inputs with no regard to the supply voltage. This device can be used to interface 5V to 3V.

All inputs and outputs are equipped with protection circuits against static discharge, giving them 2KV ESD immunity and transient excess voltage.

74VHC574

INPUT EQUIVALENT CIRCUIT

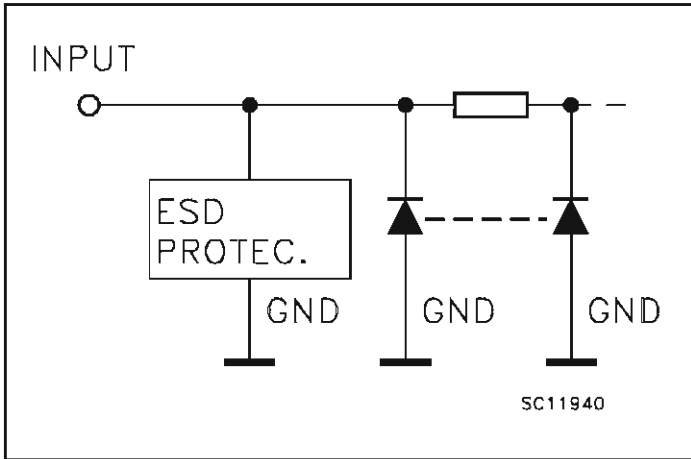

PIN DESCRIPTION

PIN No	SYMBOL	NAME AND FUNCTION
1	\overline{OE}	3-State Output Enable Input (Active LOW)
2, 3, 4, 5, 6, 7, 8, 9	D0 to D7	Data Inputs
12, 13, 14, 15, 16, 17, 18, 19	Q0 to Q7	3-State Outputs
11	CK	Clock Input (LOW-to-HIGH Edge Triggered)
10	GND	Ground (0V)
20	V _{CC}	Positive Supply Voltage

TRUTH TABLE

INPUTS			OUTPUT
\overline{OE}	CK	D	Q
H	X	X	Z
L		X	NO CHANGE
L		L	L
L		H	H

X : Don't Care
Z : High Impedance

LOGIC DIAGRAM

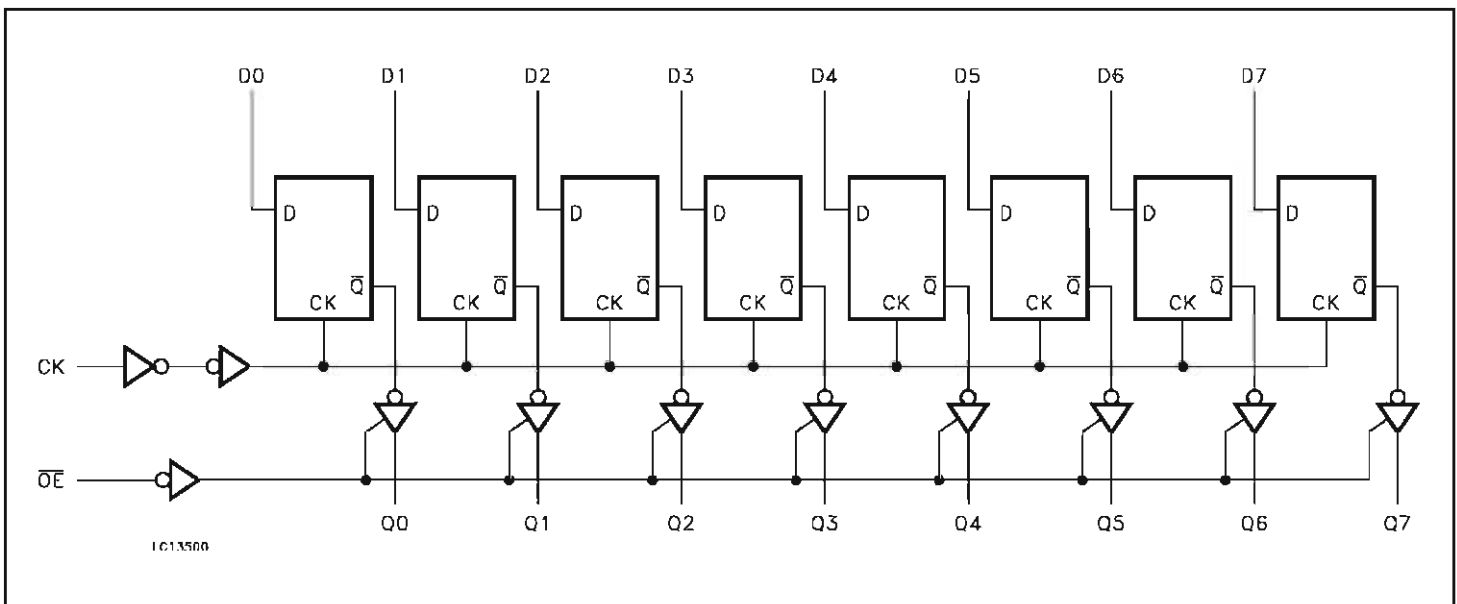

This logic diagram has not be used to estimate propagation delays

Features

- Fast Read Access Time – 120 ns, see AT27BV020 for Faster Speeds
- Dual Voltage Range Operation
 - Low Voltage Power Supply Range, 3.0V to 3.6V
 - or Standard 5V \pm 10% Supply Range
- Compatible with JEDEC Standard AT27C020
- Low Power CMOS Operation
 - 20 μ A Max (Less than 1 μ A Typical) Standby for $V_{CC} = 3.6V$
 - 29 mW Max Active at 5 MHz for $V_{CC} = 3.6V$
- JEDEC Standard Packages
 - 32-lead PLCC
 - 32-lead TSOP
 - 32-lead VSOP
- High Reliability CMOS Technology
 - 2,000V ESD Protection
 - 200 mA Latchup Immunity
- Rapid Programming Algorithm – 100 μ s/Byte (Typical)
- Two-line Control
- CMOS and TTL Compatible Inputs and Outputs
 - JEDEC Standard for LVTTTL
- Integrated Product Identification Code
- Industrial Temperature Range
- Green (Pb/Halide-free) Packaging Option

1. Description

The AT27LV020A is a high-performance, low-power, low-voltage 2,097,152 bit one-time programmable read-only memory (OTP EPROM) organized as 256K by 8 bits. It requires only one supply in the range of 3.0 to 3.6V in normal read mode operation, making it ideal for fast, portable systems using battery power.

Atmel's innovative design techniques provide fast speeds that rival 5V parts while keeping the low power consumption of a 3V supply. At $V_{CC} = 3.0V$, any byte can be accessed in less than 120 ns. With a typical power dissipation of only 18 mW at 5 MHz and $V_{CC} = 3.3V$, the AT27LV020A consumes less than one fifth the power of a standard 5V EPROM. Standby mode supply current is typically less than 1 μ A at 3.3V.

The AT27LV020A is available in industry-standard JEDEC approved one-time programmable (OTP) plastic PLCC, TSOP, and VSOP. All devices feature two-line control (\overline{CE} , \overline{OE}) to give designers the flexibility to prevent bus contention.

The AT27LV020A operating with V_{CC} at 3.0V produces TTL level outputs that are compatible with standard TTL logic devices operating at $V_{CC} = 5.0V$. The device is also capable of standard 5-volt operation making it ideally suited for dual supply range systems or card products that are pluggable in both 3-volt and 5-volt hosts.

Atmel's AT27LV020A has additional features to ensure high quality and efficient production use. The Rapid Programming Algorithm reduces the time required to program the part and guarantees reliable programming. Programming time is typically only 100 μ s/byte. The Integrated Product Identification Code electronically identifies the device and manufacturer. This feature is used by industry standard programming equipment to select the proper programming algorithms and voltages. The AT27LV020A programs exactly the same way as a standard 5V AT27C020 and uses the same programming equipment.



**2-Megabit
(256K x 8)
Low Voltage
OTP EPROM**

AT27LV020A

0549F-EPROM-05/05





2. Pin Configurations

Pin Name	Function
A0 - A17	Addresses
O0 - O7	Outputs
\overline{CE}	Chip Enable
\overline{OE}	Output Enable
\overline{PGM}	Program Strobe
NC	No Connect

2.1 32-lead TSOP/VSOP (Type 1) Top View

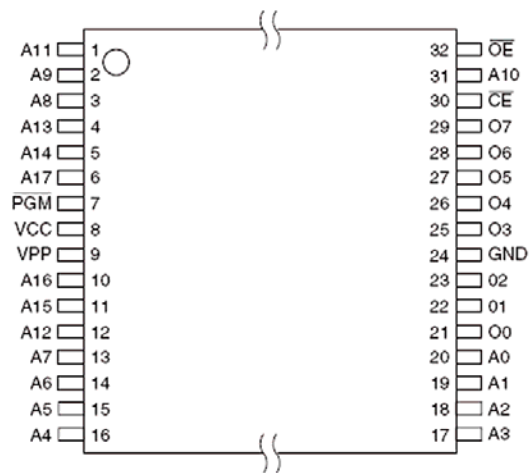

2.2 32-lead PLCC – Top View

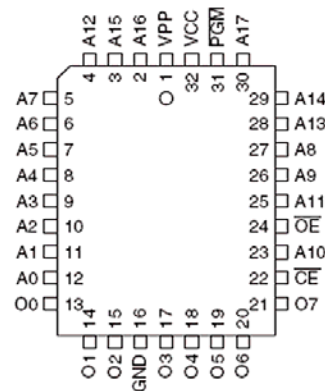

AT27LV020A

AT27LV020A

3. System Considerations

Switching between active and standby conditions via the Chip Enable pin may produce transient voltage excursions. Unless accommodated by the system design, these transients may exceed datasheet limits, resulting in device non-conformance. At a minimum, a 0.1 μF high frequency, low inherent inductance, ceramic capacitor should be utilized for each device. This capacitor should be connected between the V_{CC} and Ground terminals of the device, as close to the device as possible. Additionally, to stabilize the supply voltage level on printed circuit boards with large EPROM arrays, a 4.7 μF bulk electrolytic capacitor should be utilized, again connected between the V_{CC} and Ground terminals. This capacitor should be positioned as close as possible to the point where the power supply is connected to the array.

4. Block Diagram

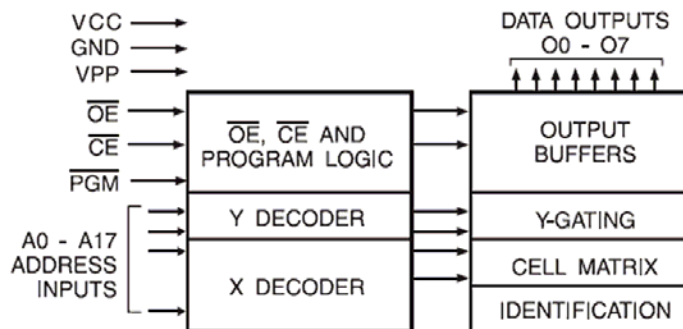

5. Absolute Maximum Ratings*

Temperature Under Bias.....	-40°C to +85°C
Storage Temperature	-65°C to +125°C
Voltage on any Pin with with Respect to Ground.....	-2.0V to +7.0V ⁽¹⁾
Voltage on A9 with Respect to Ground	-2.0V to +14.0V ⁽¹⁾
V_{PP} Supply Voltage with Respect to Ground	-2.0V to +14.0V ⁽¹⁾

*NOTICE: Stresses beyond those listed under "Absolute Maximum Ratings" may cause permanent damage to the device. This is a stress rating only and functional operation of the device at these or any other conditions beyond those indicated in the operational sections of this specification is not implied. Exposure to absolute maximum rating conditions for extended periods may affect device reliability.

Notes: 1. Minimum voltage is -0.6V DC which may undershoot to -2.0V for pulses of less than 20 ns. Maximum output pin voltage is $V_{CC} + 0.75\text{V}$ DC which may be exceeded if certain precautions are observed (consult application notes) and which may overshoot to +7.0V for pulses of less than 20 ns.

BA7046/BA7046F

SYNC Separator IC with AFC

● Block diagrams

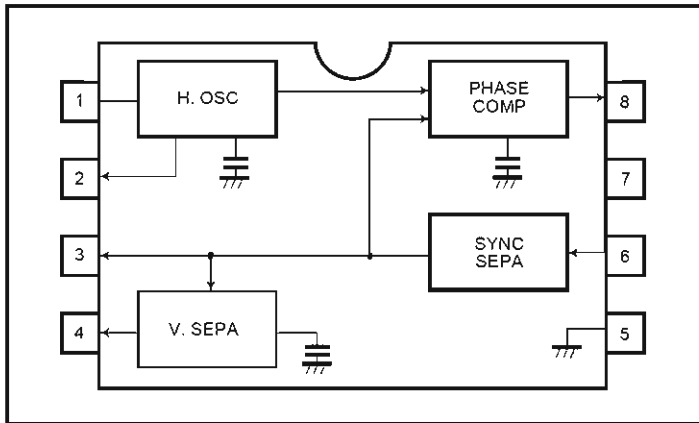

● Pin descriptions

Pin No.	Function
1	Horizontal oscillator resistor
2	H _b output
3	SYNC output (open collector)
4	V _D output
5	GND
6	Video input
7	Power supply
8	Phase comparator output

BA7046

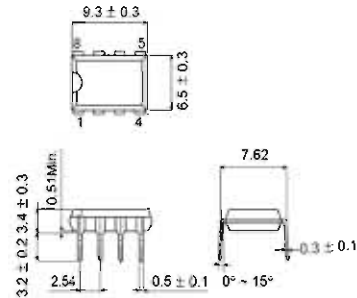

BA7046F

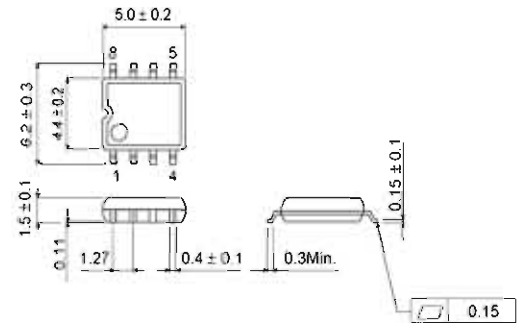

● Input / output circuits

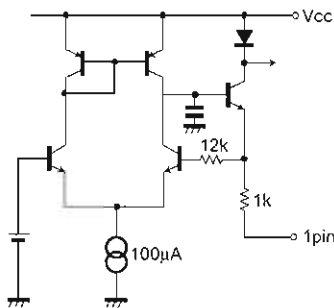

Fig. 1

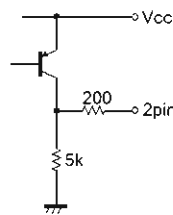

Fig. 2

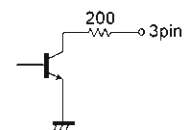

Fig. 3

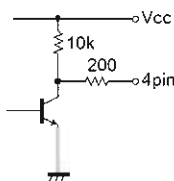

Fig. 4

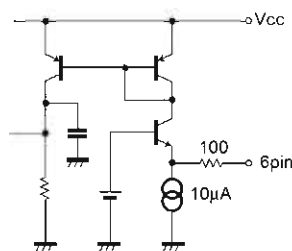

Fig. 5

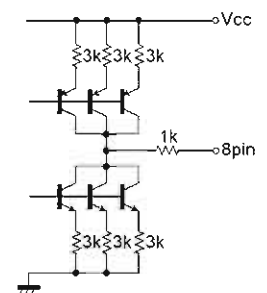
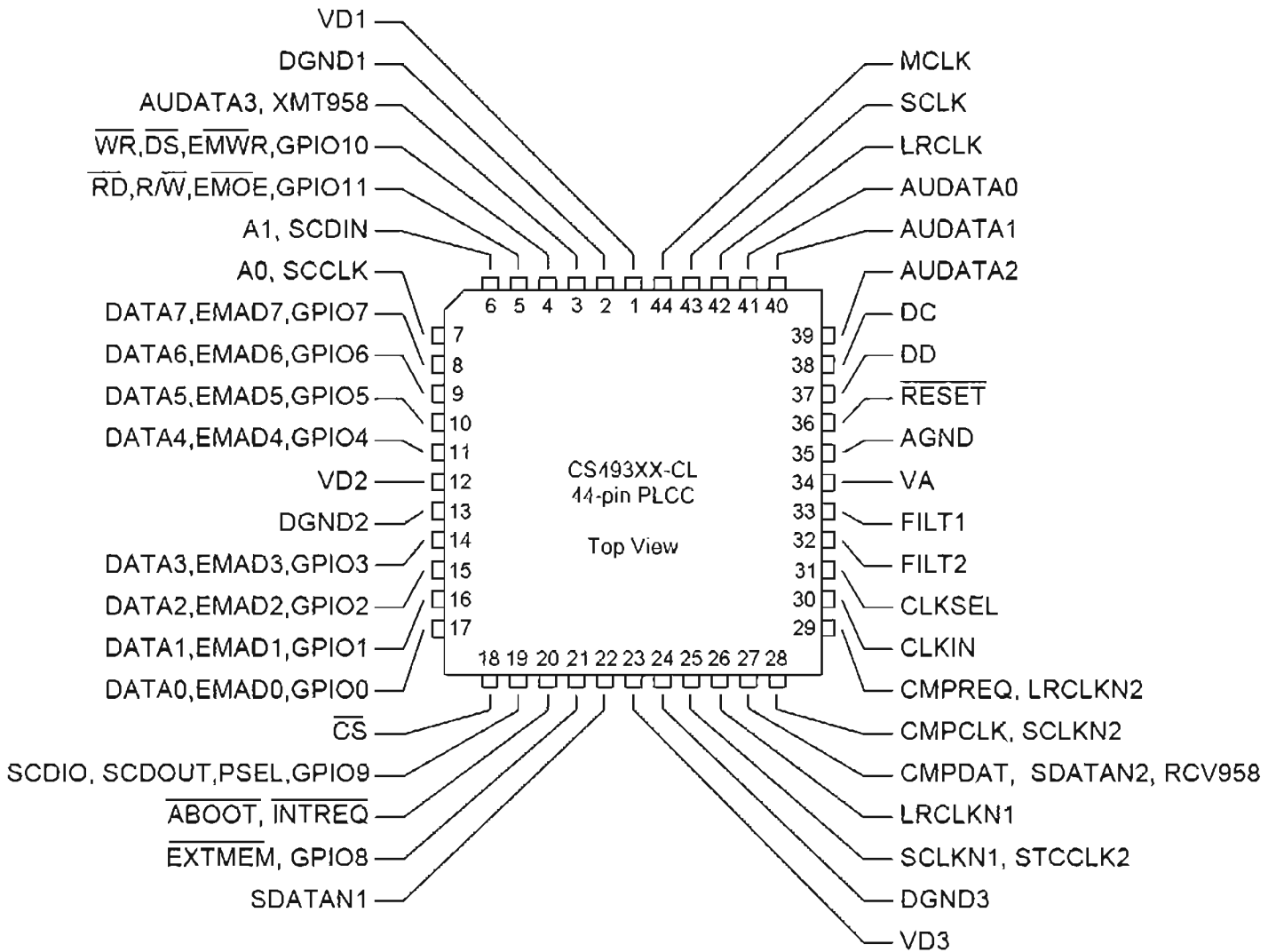

Fig. 6

24-Bit Multi Standard
Audio DSP Decoder

CS493263



8-channel analog multiplexer / demultiplexer

BU4051BC / BU4051BCF / BU4051BCFV

The BU4051BC, BU4051BCF and BU4051BCFV are analog multiplexers / demultiplexers which use three-input digital signals for control via an 8-channel analog switch.

These products feature high on / off output voltage ratio and low crosstalk between analog switches.

●Block diagram

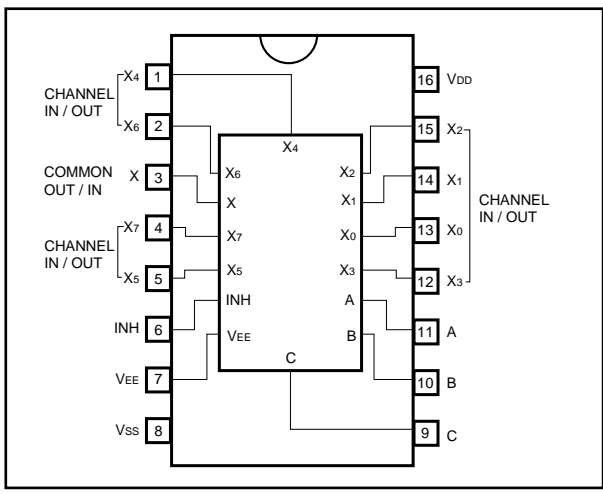

●Logic circuit diagram

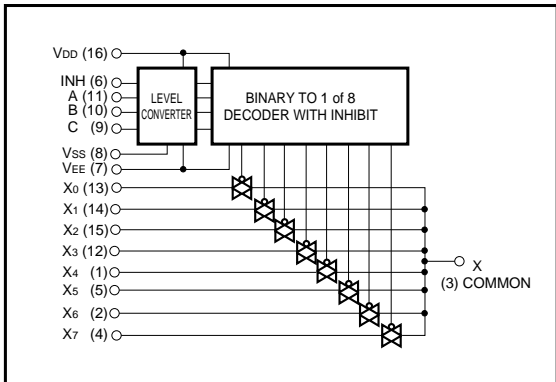

●Truth table

INH	A	B	C	ON SWITCH
L	L	L	L	X ₀
L	H	L	L	X ₁
L	L	H	L	X ₂
L	H	H	L	X ₃
L	L	L	H	X ₄
L	H	L	H	X ₅
L	L	H	H	X ₆
L	H	H	H	X ₇
H	X	X	X	NONE

X: Irrelevant

8-bit compatible shift / store register

BU4094BC / BU4094BCF / BU4094BCFV

The BU4094BC, BU4094BCF, and BU4094BCFV are shift / store registers, each consisting of an 8-bit register and an 8-bit latch.

As the data in the shift register can be latched by an asynchronous strobe input, it is possible to hold the output in the data transfer mode.

The tri-state parallel output can be connected directly with an 8-bit bus line.

These registers are suitable for in-line / parallel data conversion, data receivers and other similar applications.

●Logic circuit diagram

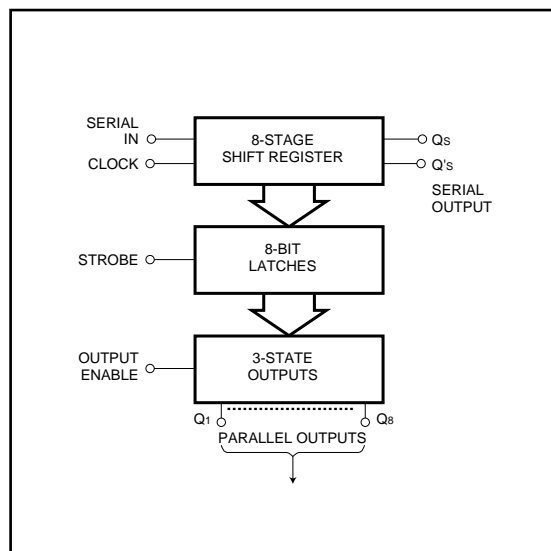

●Block diagram

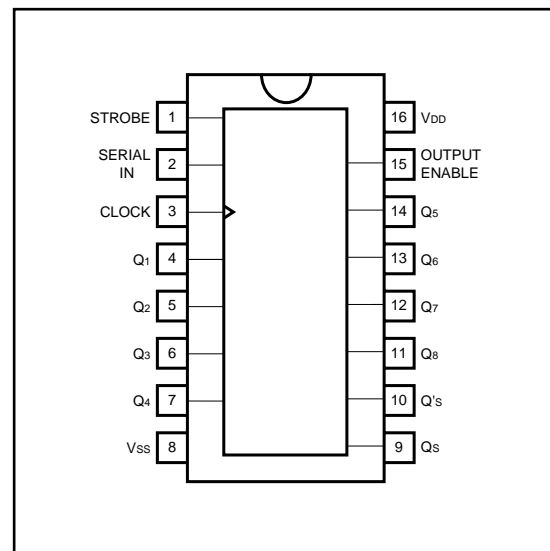

●Truth table

CLOCK	OUTPUT ENABLE	STROBE	SERIAL IN	Parallel output		Serial output	
				Q ₁	Q _n	Q _s	Q' _s
┌	H	H	L	L	Q _{n-1}	Q ₇	NC
┌	H	H	H	H	Q _{n-1}	Q ₇	NC
┌	H	L	X	NC	NC	Q ₇	NC
┌	L	X	X	Z	Z	Q ₇	NC
└	H	X	X	NC	NC	NC	Q _s
└	L	X	X	Z	Z	NC	Q _s

NC: No Change Z: High Impedance X: Irrelevant

CS4391

24-Bit, 192 kHz Stereo DAC with Volume Control

Features

- Complete Stereo DAC System: Interpolation, D/A, Output Analog Filtering
- 108 dB Dynamic Range
- 94 dB THD+N
- Direct Stream Digital Mode
- Low Clock Jitter Sensitivity
- +5 V to +3 V Power Supply
- ATAPI Mixing
- On-Chip Digital De-emphasis for 32, 44.1, and 48 kHz
- Volume Control with Soft Ramp
 - 119 dB Attenuation
 - 1 dB Step Size
 - Zero Crossing Click-Free Transitions
- 36 mW with 3 V supply
- Direct Interface with 5 V to 1.8 V Logic

Description

The CS4391 is a complete stereo digital-to-analog system including digital interpolation, fourth-order delta-sigma digital-to-analog conversion, digital de-emphasis, volume control, channel mixing and analog filtering. The advantages of this architecture include: ideal differential linearity, no distortion mechanisms due to resistor matching errors, no linearity drift over time and temperature and a high tolerance to clock jitter.

The CS4391 accepts PCM data at sample rates from 2 kHz to 192 kHz, DSD audio data, consumes very little power and operates over a wide power supply range. These features are ideal for DVD, A/V receivers, CD and set-top box systems.

ORDERING INFORMATION

CS4391-KZ	20-pin TSSOP	-10 to 70 °C
CDB4391	Evaluation Board	

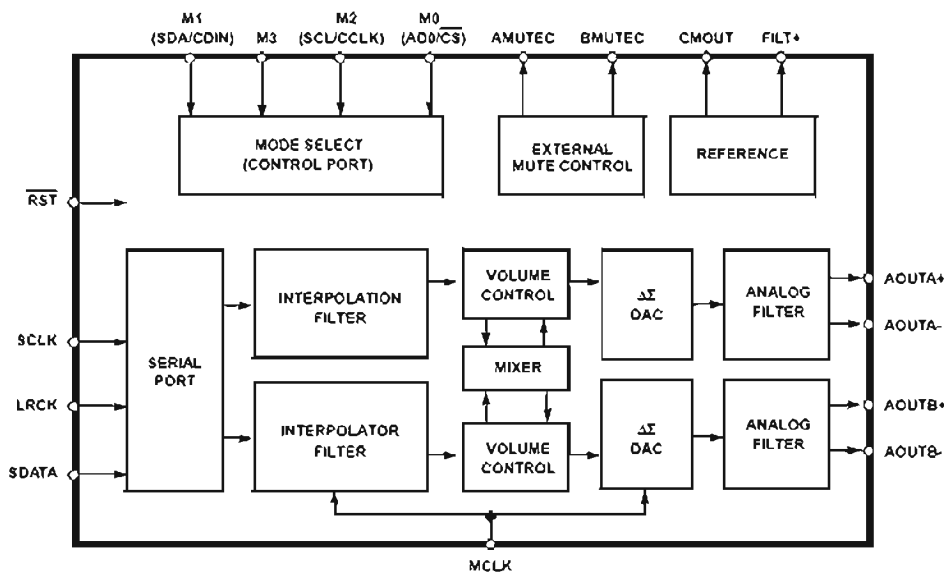



CS4391

PIN DESCRIPTION - PCM DATA MODE

Reset	$\overline{\text{RST}}$	1	20	AMUTEC	Channel A Mute Control
Logic Voltage	VL	2	19	AOUTA-	Differential Output
Serial Data	SDATA	3	18	AOUTA+	Differential Output
Serial Clock	SCLK	4	17	VA	Analog Power
Left/Right Clock	LRCK	5	16	AGND	Analog Ground
Master Clock	MCLK	6	15	AOUTB+	Differential Output
	M3	7	14	AOUTB-	Differential Output
	(SCL/CCLK) M2	8	13	BMUTEC	Channel B Mute Control
	(SDA/CDIN) M1	9	12	CMOUT	Common Mode Voltage
	(AD0/CS) M0	10	11	FILT+	Positive Voltage Reference

PIN DESCRIPTION - DSD MODE

Reset	$\overline{\text{RST}}$	1	20	AMUTEC	Refer to PCM Mode
Logic Voltage	VL	2	19	AOUTA-	Refer to PCM Mode
Channel A Data	DSD_A	3	18	AOUTA+	Refer to PCM Mode
Channel B Data	DSD_B	4	17	VA	Refer to PCM Mode
DSD Mode Select	DSD_MODE	5	16	AGND	Refer to PCM Mode
Master Clock	MCLK	6	15	AOUTB+	Refer to PCM Mode
DSD Serial Clock	DSD_SCLK	7	14	AOUTB-	Refer to PCM Mode
Refer to PCM Mode	(SCL/CCLK) M2	8	13	BMUTEC	Refer to PCM Mode
Refer to PCM Mode	(SDA/CDIN) M1	9	12	CMOUT	Refer to PCM Mode
Refer to PCM Mode	(AD0/CS) M0	10	11	FILT+	Refer to PCM Mode

M74HCU04

HEX INVERTER (SINGLE STAGE)

DESCRIPTION

The M54/74HCU04 is a high speed CMOS HEX INVERTER (SINGLE STAGE) fabricated in silicon gate C²MOS technology. It has the same high speed performance of LSTTL combined with true CMOS low power consumption.

As the intrnal circuit is composed of a single stage inverter, it can be used in crystal oscillator.

All inputs are equipped with circuits against static discharge and transient excess voltage.

INPUT AND OUTPUT EQUIVALENT CIRCUIT

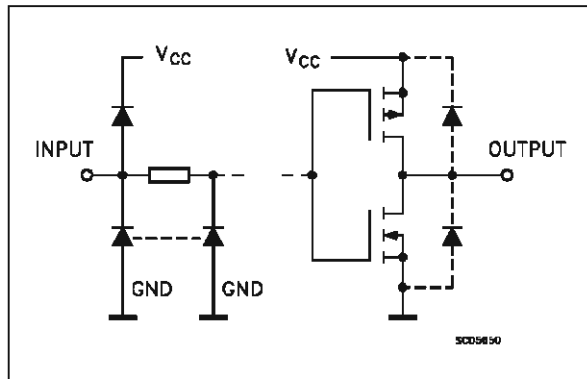

PIN DESCRIPTION

PIN No	SYMBOL	NAME AND FUNCTION
1, 3, 5, 9, 11, 13	1A to 6A	Data Inputs
2, 4, 6, 8, 10, 12	1Y to 6Y	Data Outputs
7	GND	Ground (0V)
14	Vcc	Positive Supply Voltage

B1R
(Plastic Package)

F1R
(Ceramic Package)

M1R
(Micro Package)

C1R
(Chip Carrier)

ORDER CODES :
 M54HCU04F1R M74HCU04M1R
 M74HCU04B1R M74HCU04C1R

PIN CONNECTIONS (top view)

NC = No Internal Connection



CS5360

24-Bit Stereo A/D Converter for Digital Audio

Features

- 24 Bit Conversion
- 105 dB Dynamic Range
- -95 dB THD+N
- 128X Oversampling
- Fully Differential Inputs
- Linear Phase Digital Anti-Alias Filtering
 - 21.7 kHz passband (Fs = 48kHz)
 - 85 dB stop band attenuation
 - 0.0025 dB pass band ripple
- High Pass Filter - DC Offset Removal
- Peak Signal Level Detector
 - High Resolution and Bar Graph Modes
- Pin Compatible with CS5334 and CS5335

Description

The CS5360 is a 2-channel, single +5 V supply, 24-bit analog-to-digital converter for digital audio systems. The CS5360 performs sampling, analog-to-digital conversion and anti-alias filtering, generating 24-bit values for both left and right inputs in serial form. The output word rate can be up to 50 kHz per channel.

The CS5360 uses 4th-order, delta-sigma modulation with 128X oversampling followed by digital filtering and decimation, which removes the need for an external anti-alias filter. This ADC uses a differential architecture which provides excellent noise rejection.

The CS5360 has a filter passband to 21.7 kHz. The filter has linear phase, 0.0025 dB passband ripple, and >85 dB stopband rejection. An on-chip high pass filter is also included to remove DC offsets.

ORDERING INFORMATION

CS5360-KS	-10° to 70°C	20-pin Plastic SSOP
CS5360-BS	-40° to 85°C	20-pin Plastic SSOP

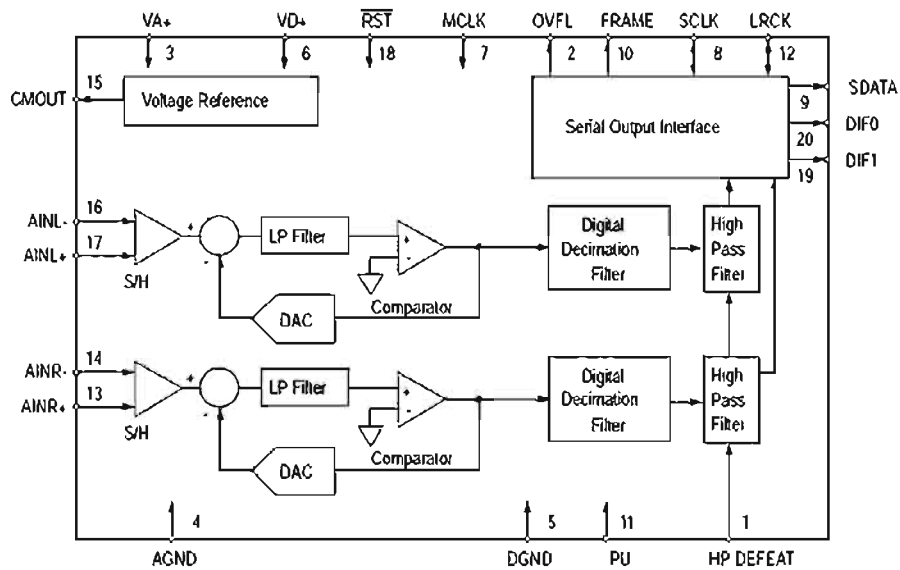



CS5360

5. PIN DESCRIPTIONS

High Pass Filter Defeat	HPDEFEAT	1	20	DIF0	Digital Interface Format 0
Overflow	OVFL	2	19	DIF1	Digital Interface Format 1
Analog Power	VA+	3	18	$\overline{\text{RST}}$	Reset
Analog Ground	AGND	4	17	AINL+	Non-Inverting Left Channel Input
Digital Ground	DGND	5	16	AINL-	Inverting Left Channel Input
Digital Power	VD+	6	15	CMOUT	Common Mode Output
Master Clock	MCLK	7	14	AINR-	Inverting Right Channel Input
Serial Data Clock	SCLK	8	13	AINR+	Non-Inverting Right Channel Input
Serial Data Output	SDATA	9	12	LRCK	Left / Right Clock
Frame Signal	FRAME	10	11	PU	Peak Update

High Pass Filter Defeat - HP DEFEAT

Pin 1, Input

Function

A high logic level on this pin disables the digital high pass filter. A low logic level on this pin enables the high pass filter.

Overflow - $\overline{\text{OVFL}}$

Pin 2, Input

Function

Overflow indicates analog input overrange, for both the Left and Right channels, since the last update request on the PEAK UPDATE (PU) pin. A value of 1 in the register indicates an overrange condition. The left channel information is output on $\overline{\text{OVFL}}$ during the left channel portion of LRCK. The right channel information is available on $\overline{\text{OVFL}}$ during the right channel portion of LRCK. The registers are updated with a high to low transition on the PEAK UPDATE pin. A 47 k Ω pull-down resistor on this pin will set the CS5360 in Master Mode.

Positive Analog Power - VA+

Pin 3, Input

Function:

Positive analog supply. Nominally +5 volts.

Analog Ground - AGND

Pin 4, Input

Function:

Analog ground reference.

DGND - Digital Ground

Pin 5, Input

Function:

Digital ground reference.



CS5360

Positive Digital Power - VD+*Pin 6, Input**Function:*

Positive digital supply. Nominally +5 volts.

Master Clock - MCLK*Pin 7, Input**Function:*

Clock source for the delta-sigma modulator sampling and digital filters. In Master Mode, the frequency of this clock must be 256x the output sample rate, F_s . In Slave Mode, the frequency of this clock must be either 256x, 384x or 512x F_s .

Serial Data Clock - SCLK*Pin 8, Input/Output**Function:*

Clocks the individual bits of the serial data out from the SDATA pin. The relationship between LRCK, SCLK and SDATA is controlled by DIF0 and DIF1. In Master Mode, SCLK is an output clock with a frequency of 64x the output sample rate, F_s . In Slave Mode, SCLK is an input.

Serial Data Output - SDATA*Pin 9, Output**Function:*

Two's complement MSB-first serial data of 24 bits is output on this pin. Included in the serial data output is the 8-bit Input Signal Level Bits. The data is clocked out via the SCLK clock and the channel is determined by LRCK. The relationship between LRCK, SCLK and SDATA is controlled by DIF0 and DIF1.

Peak Update - PU*Pin 11, Input**Function:*

Transfers the Peak Signal Level contents of the Active Registers to the Output Registers on a high to low transition on this pin. This transition will also reset the Active register.

Frame Signal - FRAME*Pin 10, Output**Function:*

Frames the Peak Signal Level (PSL) Bits. FRAME goes high coincident with the leading edge of the first PSL bit and falls coincident with the trailing edge of the last PSL bit as shown in Figures 8-10. A 47 k Ω pull-down resistor on this pin will set the Peak Signal Level Monitoring format to "Bar Graph" mode.

Left/Right Clock - LRCK*Pin 12, Input/Output**Function:*

LRCK determines which channel, left or right, is to be output on SDATA. The relationship between LRCK, SCLK and SDATA is controlled by DIF0 and DIF1. Although the outputs for each channel are transmitted at different times, Left/Right pairs represent simultaneously sampled analog inputs. In Master Mode, LRCK is an output clock whose frequency is equal to the output sample rate, F_s . In Slave Mode, LRCK is an input clock whose frequency must be equal to F_s .



CS5360

Differential Right Channel Analog Input - AINR+, AINR-*Pin 13 and Pin 14, Input**Function:*

Analog input connections of the right channel differential inputs. Typically 2 Vrms differential (1Vrms for each input pin) for a full-scale analog input signal.

Common Mode Output - CMOUT*Pin 15, Output**Function:*

This output, nominally 2.2 V, can be used to bias the analog input circuitry to the common mode voltage of the CS5360. CMOUT is not buffered and the maximum current is 10 μ A.

Differential Left Channel Analog Input - AINL+, AINL-*Pin 16 and Pin 17, Input**Function:*

Analog input connections of the left channel differential inputs. Typically 2 Vrms differential (1Vrms for each input pin) for a full-scale analog input signal.

Reset - $\overline{\text{RST}}$ *Pin 18, Input**Function:*

A low logic level on this pin activates Reset.

Digital Interface Format - DIF0, DIF1*Pins 19 and 20, Input**Function:*

These two pins select one of 3 digital interface formats or power-down. The format determines the relationship between SCLK, LRCK and SDATA. The formats are detailed in Figures 8-10.

TSH95

HIGH SPEED LOW POWER QUAD OPERATIONAL AMPLIFIER WITH DUAL **STANDBY** POSITION

- **2 SEPARATE STANDBY** : REDUCED CONSUMPTION AND HIGH IMPEDANCE OUTPUTS
- LOW SUPPLY CURRENT : 4.5mA
- HIGH SPEED : 150MHz - 110V/ μ s
- UNITY GAIN STABILITY
- LOW OFFSET VOLTAGE : 4mV
- LOW NOISE 4.2 nV/ \sqrt Hz
- LOW COST
- SPECIFIED FOR **600 Ω** AND **150 Ω** LOADS
- HIGH VIDEO PERFORMANCES :
Differential Gain : 0.03%
Differential Phase : 0.07°
Gain Flatness : 6MHz, 0.1dB max. @ 10dB gain
- HIGH AUDIO PERFORMANCES
- ESD TOLERANCE : 2kV

DESCRIPTION

The TSH95 is a quad low power high frequency op-amp, designated for high quality video processing. The device offers an excellent speed consumption ratio with 4.5mA per amplifier for 150MHz bandwidth.

High slew rate and low noise make it also suitable for high quality audio applications.

The TSH95 offers 2 separate complementary **STANDBY** pins :

- STANDBY 1 acting on both n° 1 & 2 operators
- STANDBY 2 acting on both n° 3 & 4 operators

They reduce the consumption of the corresponding operatorS and put the output in a high impedance state.

ORDER CODE

Part Number	Temperature Range	Package
		D
TSH95I	-40°C, +125°C	•

D = Small Outline Package (SO) - also available in Tape & Reel (DT)

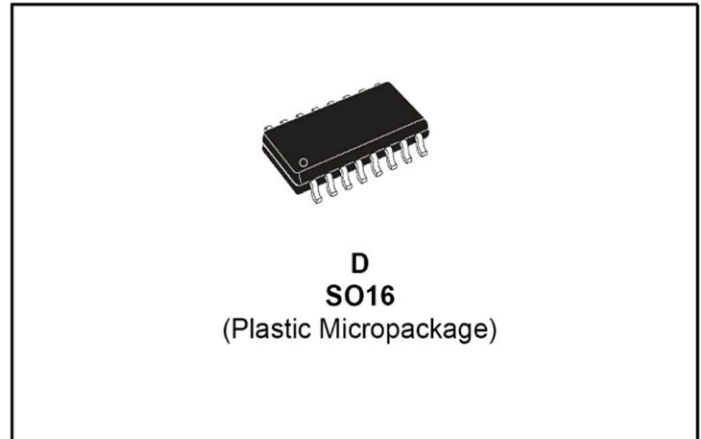

PIN CONNECTIONS (top view)

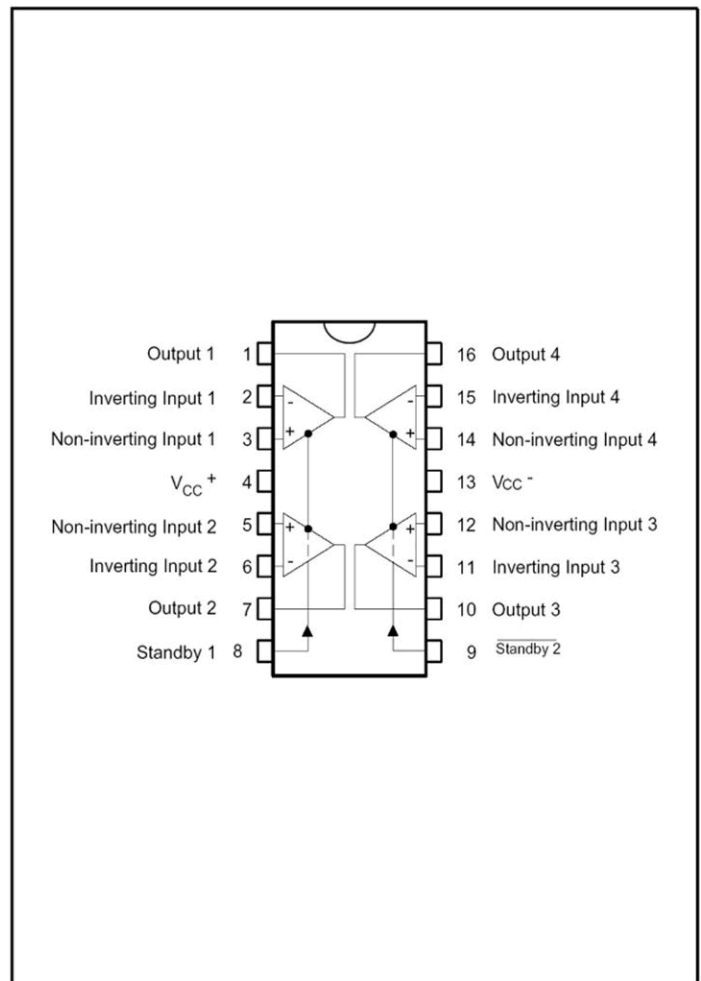

500mA Regulator

Monolithic IC MM156□□F

Outline

This IC is a small, stable power supply with output voltage precision of $\pm 2\%$ (when $I_o = 250\text{mA}$), maximum output current of 500mA, and I/O voltage difference of 0.3V typ. at 250mA. Output noise reduction and output ON/OFF control pins are provided, making it ideal for portable equipment.

Features

- | | |
|--------------------------------|--|
| 1. No-load current consumption | 1.9mA typ. |
| 2. I/O voltage difference | 0.3V typ. ($I_o=250\text{mA}$) |
| 3. Ripple rejection rate | 64dB typ. ($f=120\text{Hz}$, $V_{\text{RIPPLE}}=1\text{VP-P}$, $I_o=250\text{mA}$) |
| 4. Output current | 500mA max. |
| 5. Output noise voltage | 75 μVrms typ. |
| 6. Output voltage rank | 1.5 ~ 5.0V (0.1V steps) |
| 7. Output ON/OFF control | High→ON, Low→OFF |

Package

SOP-7B

Applications

1. Cordless telephone
2. Portable equipment, etc.

Pin Assignment

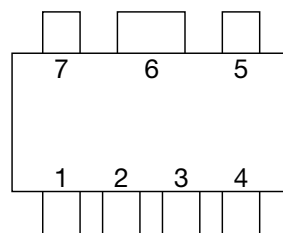

SOP-7B
(TOP VIEW)

1	V_o
2	NC
3	GND
4	C_n
5	CONT
6	Sub
7	V_{IN}



CS5330A
CS5331A

8-Pin, Stereo A/D Converter for Digital Audio

Features

- Single +5 V Power Supply
- 18-Bit Resolution
- 94 dB Dynamic Range
- Linear Phase Digital Anti-Alias Filtering
0.05dB Passband Ripple
80dB Stopband Rejection
- Low Power Dissipation: 150 mW
Power-Down Mode for Portable Applications
- Complete CMOS Stereo A/D System
Delta-Sigma A/D Converters
Digital Anti-Alias Filtering
S/H Circuitry and Voltage Reference
- Adjustable System Sampling Rates
including 32kHz, 44.1 kHz & 48kHz

General Description

The CS5330A / 31A is a complete stereo analog-to-digital converter which performs anti-alias filtering, sampling and analog-to-digital conversion generating 18-bit values for both left and right inputs in serial form. The output sample rate can be infinitely adjusted between 2 and 50 kHz.

The CS5330A / 31A operates from a single +5V supply and requires only 150 mW for normal operation, making it ideal for battery-powered applications.

The ADC uses delta-sigma modulation with 128X oversampling, followed by digital filtering and decimation, which removes the need for an external anti-alias filter. The linear-phase digital filter has a passband to 21.7 kHz, 0.05 dB passband ripple and >80 dB stopband rejection. The device also contains a high pass filter to remove DC offsets.

The device is available in a 0.208" wide, 8-pin surface mount package.

ORDERING INFORMATION:

Model	Temp. Range	Package Type
CS5330A-KS	-10° to 70°C	8-pin plastic SOIC
CS5331A-KS	-10° to 70°C	8-pin plastic SOIC
CS5330A-BS	-40° to +85°C	8-pin plastic SOIC
CS5331A-BS	-40° to +85°C	8-pin plastic SOIC

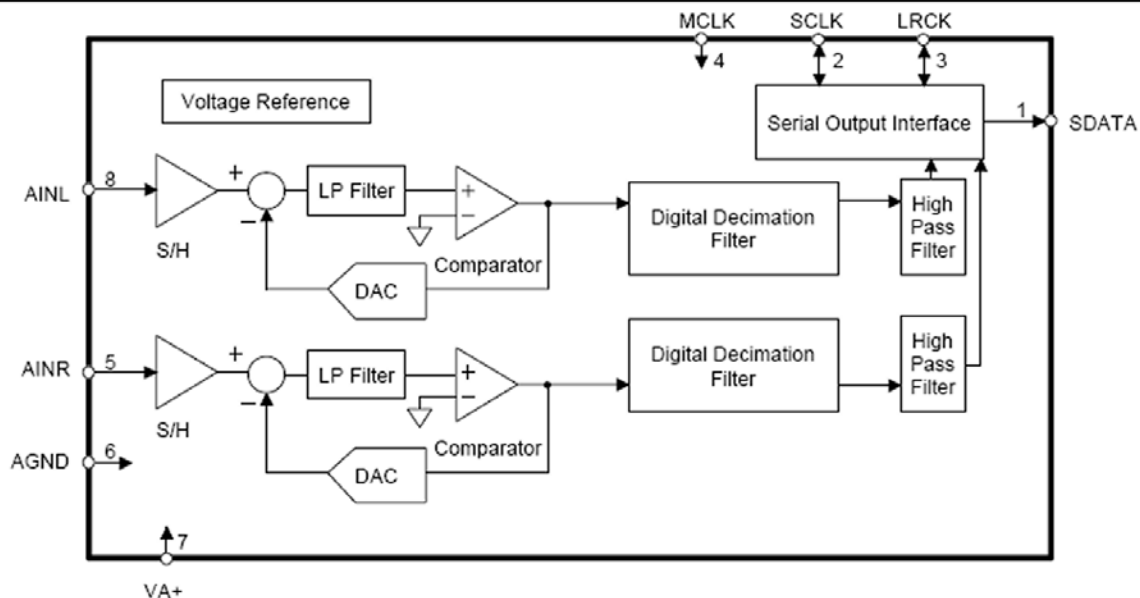



CS5330A/CS5331A

PIN DESCRIPTIONS

SERIAL DATA OUTPUT	SDATA		AINL	LEFT ANALOG INPUT
SERIAL DATA CLOCK	SCLK		VA+	ANALOG POWER
LEFT/RIGHT CLOCK	LRCK		AGND	ANALOG GROUND
MASTER CLOCK	MCLK		AINR	RIGHT ANALOG INPUT

Power Supply Connections

VA+ - Positive Analog Power, PIN 7.

Positive analog supply (Nominally +5V).

AGND - Analog Ground, PIN 6.

Analog ground reference.

Analog Inputs

AINL - Analog Left Channel Input, PIN 8.

Analog input for the left channel. Typically 4Vpp for a full-scale input signal.

AINR - Analog Right Channel Input, PIN 5.

Analog input for the right channel. Typically 4Vpp for a full-scale input signal.

Digital Inputs

MCLK - Master Clock Input, PIN 4.

Source for the delta-sigma modulator sampling and digital filter clock. Sample rates and digital filter characteristics scale to the MCLK frequency.

Digital Inputs or Outputs

SCLK - Serial Data Clock, PIN 2.

SCLK is an input clock at any frequency from 32× to 64× the output word rate. SCLK can also be an output clock at 64× if in the Master Mode. Data is clocked out on the falling edge of SCLK.

LRCK - Left/Right Clock, PIN 3.

LRCK selects the left or right channel for output on SDATA. The LRCK frequency must be at the output sample rate. LRCK is an output clock if in Master Mode. Although the outputs of each channel are transmitted at different times, the two words in an LRCK cycle represent simultaneously sampled analog inputs.

Digital Outputs

SDATA - Audio Serial Data Output, PIN 1.

Two's complement MSB-first serial data is output on this pin. A 47 kohm resistor on this pin will place the CS5330A/31A into Master Mode.

TOSHIBA**TC9459N/F**

TOSHIBA CMOS DIGITAL INTEGRATED CIRCUIT SILICON MONOLITHIC

TC9459N, TC9459F

ELECTRONIC VOLUME CONTROL

The TC9459N, TC9459F are electronic volume control ICs developed for use in home stereos and other audio equipment.

Using serial data input from external sources, it controls the sound volume, balance and loudness circuits.

FEATURES

- Sound volume can be controlled in 91 steps from 0 to -89dB or up to an infinite level in 1dB increments.
- Incorporating two channels of volume control circuits, the device allows independent volume control : therefore, it also provides the balancing function.
- A loudness circuit (20dB tap) is built in.
- Can operate with a single or dual power supplies.
- Can control up to 4 chips on the same bus by using chip select input.
- Thanks to its polysilicon resistor, the device allows you to configure a low-distortion, high-performance volume control system.

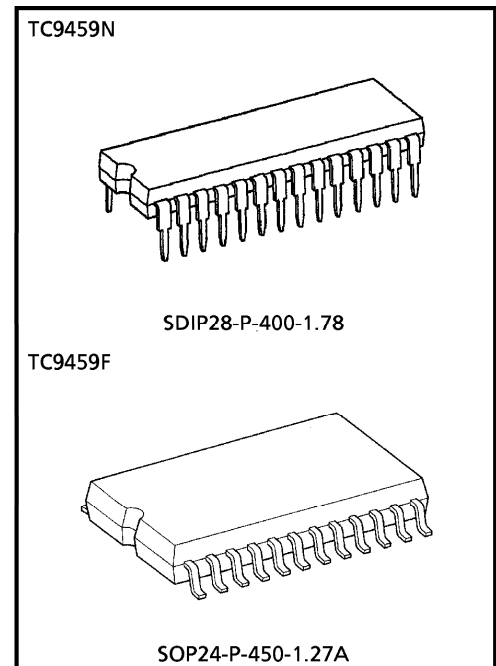

Weight

SDIP28-P-400-1.78 : 2.2g (Typ.)
 SOP24-P-450-1.27A : 0.44g (Typ.)

PIN CONNECTIONS

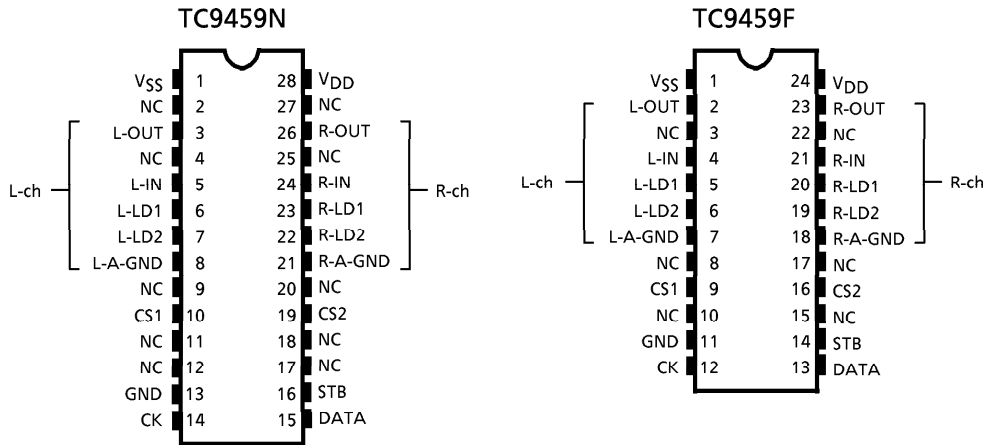

BLOCK DIAGRAM (TC9459N)

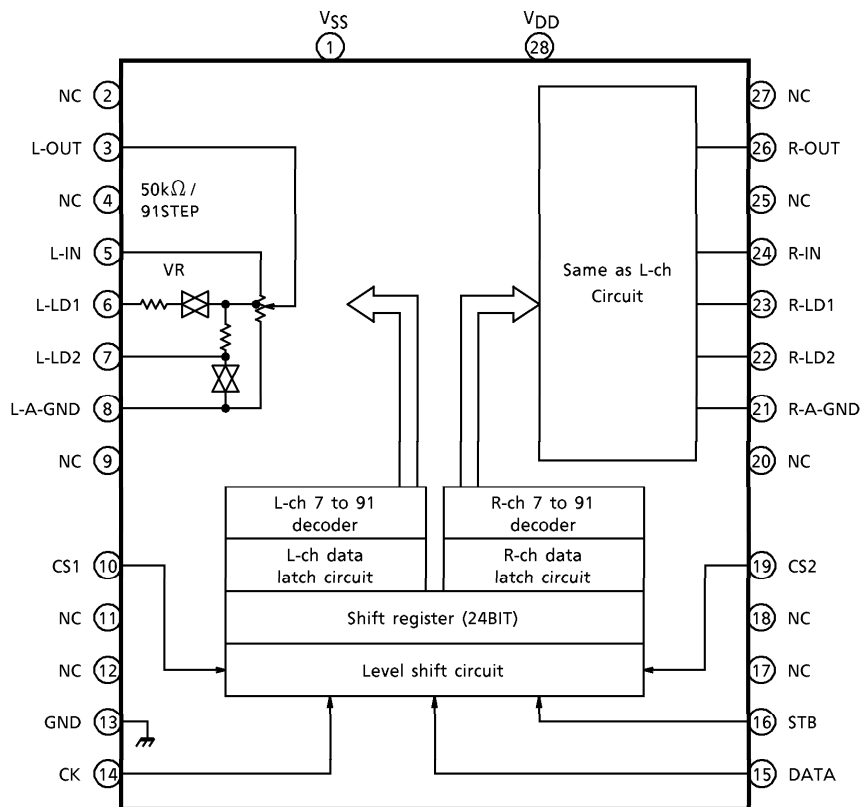

BLOCK DIAGRAM (TC9459F)

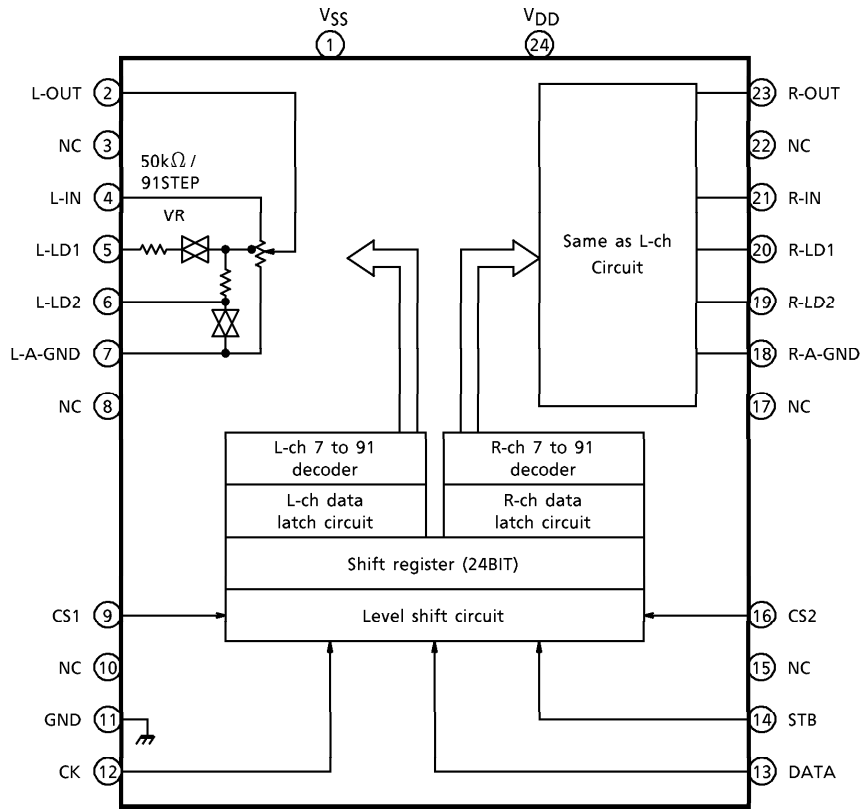

TOSHIBA**TC9459N/F****PIN DESCRIPTION**

Numeral in () means the pin No. of TC9459F.

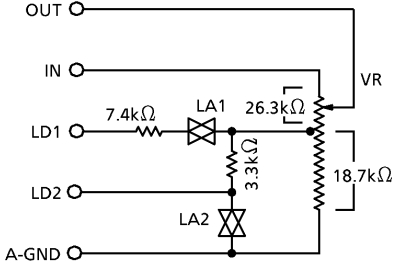
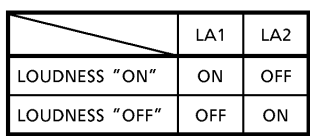
PIN No.	SYMBOL	PIN NAME	FUNCTION	REMARK	
1 (1)	V _{SS}	Negative power supply pin	When using dual power supplies $V_{DD} = 6.0 \sim 17V$ $GND = 0V$ $V_{SS} = -6.0 \sim -17V$ When using a single power supply $V_{DD} = 6.0 \sim 18V$ $GND = V_{SS} = 0V$	—	
28 (24)	V _{DD}	Positive power supply pin			
13 (11)	GND	Digital GND pin			
3 (2)	L-OUT	Volume output pin	• Volume circuit 	—	
26 (23)	R-OUT				
5 (4)	L-IN	Volume input pin			
24 (21)	R-IN				
6 (5)	L-LD1	Loudness tap output pin			
23 (20)	R-LD1				
7 (6)	L-LD2				
22 (19)	R-LD2				
8 (7)	L-A-GND	Analog GND pin			
21 (18)	R-A-GND				
10 (9)	CS1	Chip select input pin	Up to 4 chips on the same bus can be used by switching over chip select code.	—	
19 (16)	CS2				
14 (12)	CK	Clock input pin	Data transfer clock input	Low threshold value input pin	
15 (13)	DATA	Data input pin	Volume setup serial data input		
16 (14)	STB	Strobe input pin	Data write strobe input		
2 (3)	NC	No connection	—	—	
27 (22)					
4					
25					
9 (8)					
20 (17)					
11					
18					
12 (10)					
17 (15)					

CS8414

96 kHz Digital Audio Receiver

CHANNEL STATUS OUTPUT	C	1	28	VERF	VALIDITY + ERROR FLAG
CS d/FREQ REPORT 1	Cd/F1	2	27	Ce/F2	CS e/FREQ REPORT 2
CS c/FREQ REPORT 0	Cc/F0	3	26	SDATA	SERIAL OUTPUT DATA
CS b/ERROR CONDITION 2	Cb/E2	4	25	ERF	ERROR FLAG
CS a/ERROR CONDITION 1	Ca/E1	5	24	M1	SERIAL PORT MODE SELECT 1
CS 0/ERROR CONDITION 0	C0/E0	6	23	M0	SERIAL PORT MODE SELECT 0
DIGITAL POWER	VD+	7	22	VA+	ANALOG POWER
DIGITAL GROUND	DGND	8	21	AGND	ANALOG GROUND
RECEIVE POSITIVE	RXP	9	20	FILT	FILTER
RECEIVE NEGATIVE	RXN	10	19	MCK	MASTER CLOCK
FRAME SYNC	FSYNC	11	18	M2	SERIAL PORT MODE SELECT 2
SERIAL DATA CLOCK	SCK	12	17	M3	SERIAL PORT MODE SELECT 3
CHANNEL SELECT/FCLOCK	CS12/FCK	13	16	SEL	FREQ/CS SELECT
USER DATA OUTPUT	U	14	15	CBL	CS BLOCK START

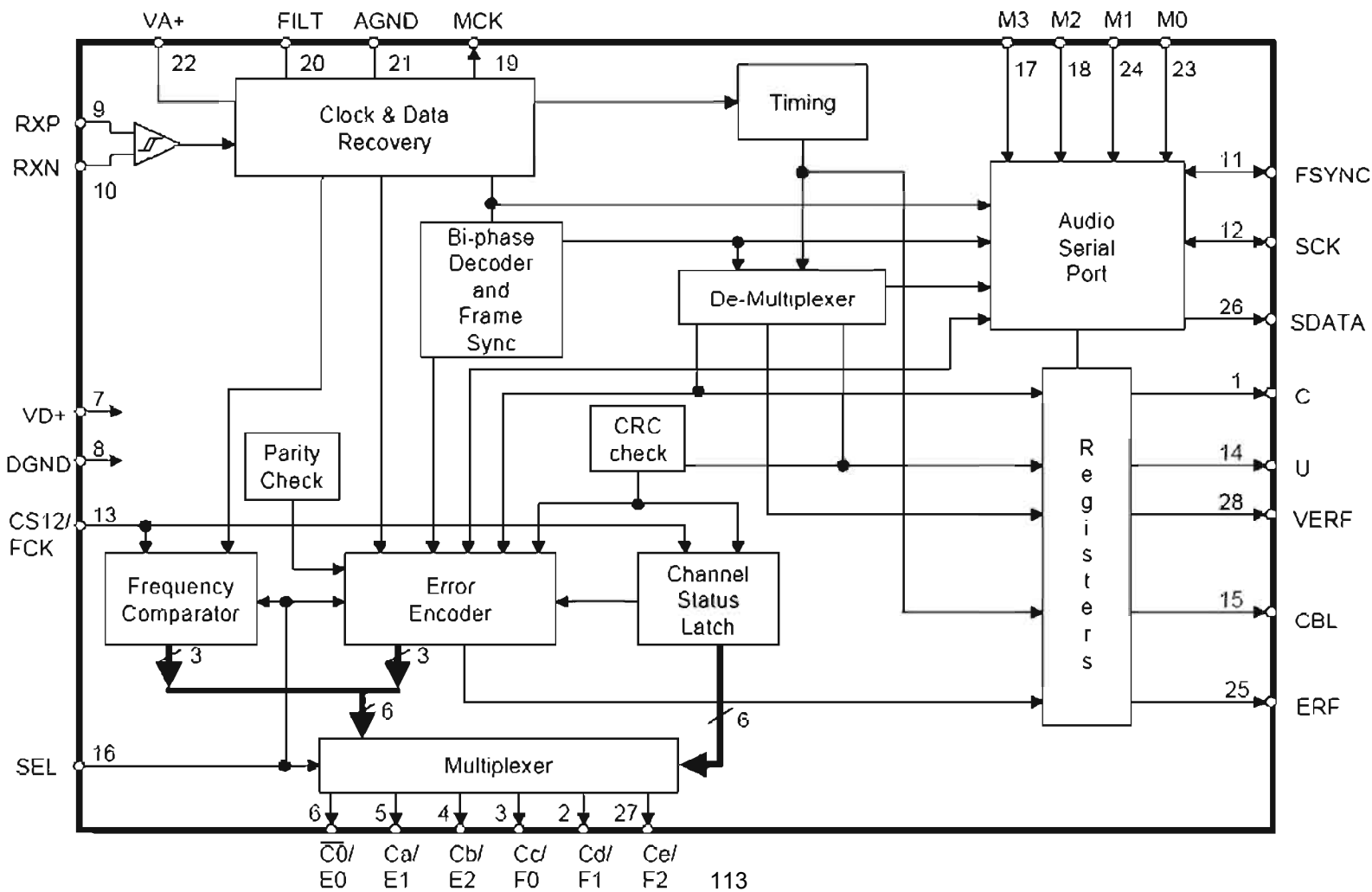

TOSHIBA

TC4051BP/BF/BFN/BFT, TC4052BP/BF/BFN/BFT, TC4053BP/BF/BFN/BFT

TOSHIBA CMOS DIGITAL INTEGRATED CIRCUIT SILICON MONOLITHIC

TC4051BP, TC4051BF, TC4051BFN, TC4051BFT
 TC4052BP, TC4052BF, TC4052BFN, TC4052BFT
 TC4053BP, TC4053BF, TC4053BFN, TC4053BFT

TC4051B SINGLE 8-CHANNEL MULTIPLEXER / DEMULTIPLEXER
 TC4052B DIFFERENTIAL 4-CHANNEL MULTIPLEXER / DEMULTIPLEXER
 TC4053B TRIPLE 2-CHANNEL MULTIPLEXER / DEMULTIPLEXER

(Note) The JEDEC SOP (FN) is not available in Japan.

TC4051B, TC4052B and TC4053B are multiplexers with capabilities of selection and mixture of analog signal and digital signal. TC4051B has 8 channels configuration. TC4052B has 4 channel×2 configuration and TC4053B has 2 channel×3 configuration. The digital signal to the control terminal turns "ON" the corresponding switch of each channel, with large amplitude ($V_{DD}-V_{EE}$) can be switched by the control signal with small logical amplitude ($V_{DD}-V_{SS}$). For example, in the case of $V_{DD}=5V$ $V_{SS}=0V$ and $V_{EE}=-5V$, signals between $-5V$ and $+5V$ can be switched from the logical circuit with single power supply of 5 volts. As the ON-resistance of each switch is low, these can be connected to the circuits with low input impedance.

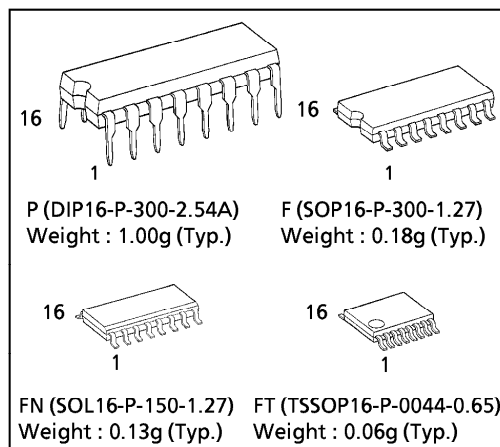
**MAXIMUM RATINGS**

CHARACTERISTIC	SYMBOL	RATING	UNIT
DC Supply Voltage	$V_{DD}-V_{SS}$	-0.5~20	V
DC Supply Voltage	$V_{DD}-V_{EE}$	-0.5~20	V
Control Input Voltage	V_{CIN}	$V_{SS}-0.5\sim V_{DD}+0.5$	V
Switch I/O Voltage	V_I/V_O	$V_{EE}-0.5\sim V_{DD}+0.5$	V
Control Input Current	I_{CIN}	±10	mA
Potential difference across I/O during ON	V_I-V_O	-0.5~0.5	V
Power Dissipation	P_D	300 (DIP) / 180 (SOIC)	mW
Operating Temperature Range	T_{opr}	-40~85	°C
Storage Temperature Range	T_{stg}	-65~150	°C

TRUTH TABLE

CONTROL INPUTS				"ON" CHANNEL		
INHIBIT	C△	B	A	TC4051B	TC4052B	TC4053B
L	L	L	L	0	0X, 0Y	0X, 0Y, 0Z
L	L	L	H	1	1X, 1Y	1X, 0Y, 0Z
L	L	H	L	2	2X, 2Y	0X, 1Y, 0Z
L	L	H	H	3	3X, 3Y	1X, 1Y, 0Z
L	H	L	L	4	—	0X, 0Y, 1Z
L	H	L	H	5	—	1X, 0Y, 1Z
L	H	H	L	6	—	0X, 1Y, 1Z
L	H	H	H	7	—	1X, 1Y, 1Z
H	*	*	*	NONE	NONE	NONE

* : Don't Care △ Except TC4052B

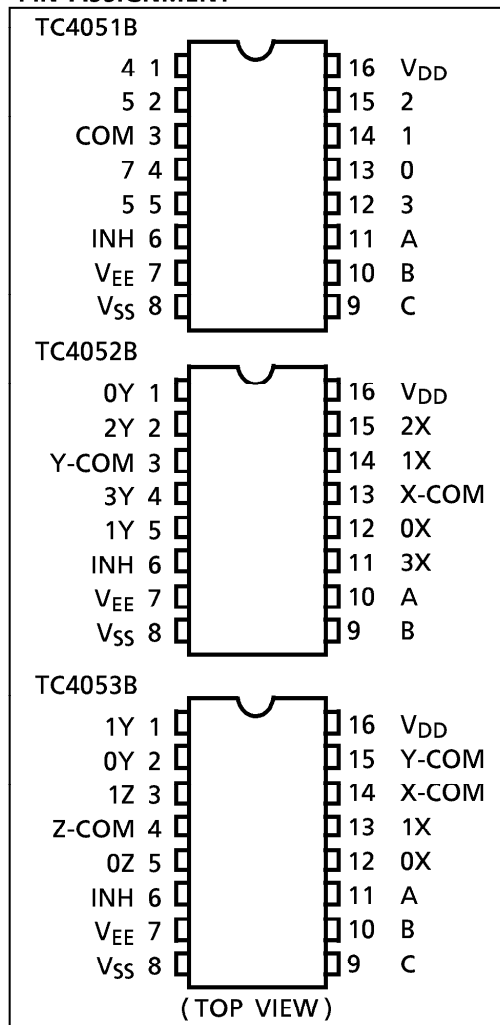
PIN ASSIGNMENT

961001EBA2

LOGIC DIAGRAM

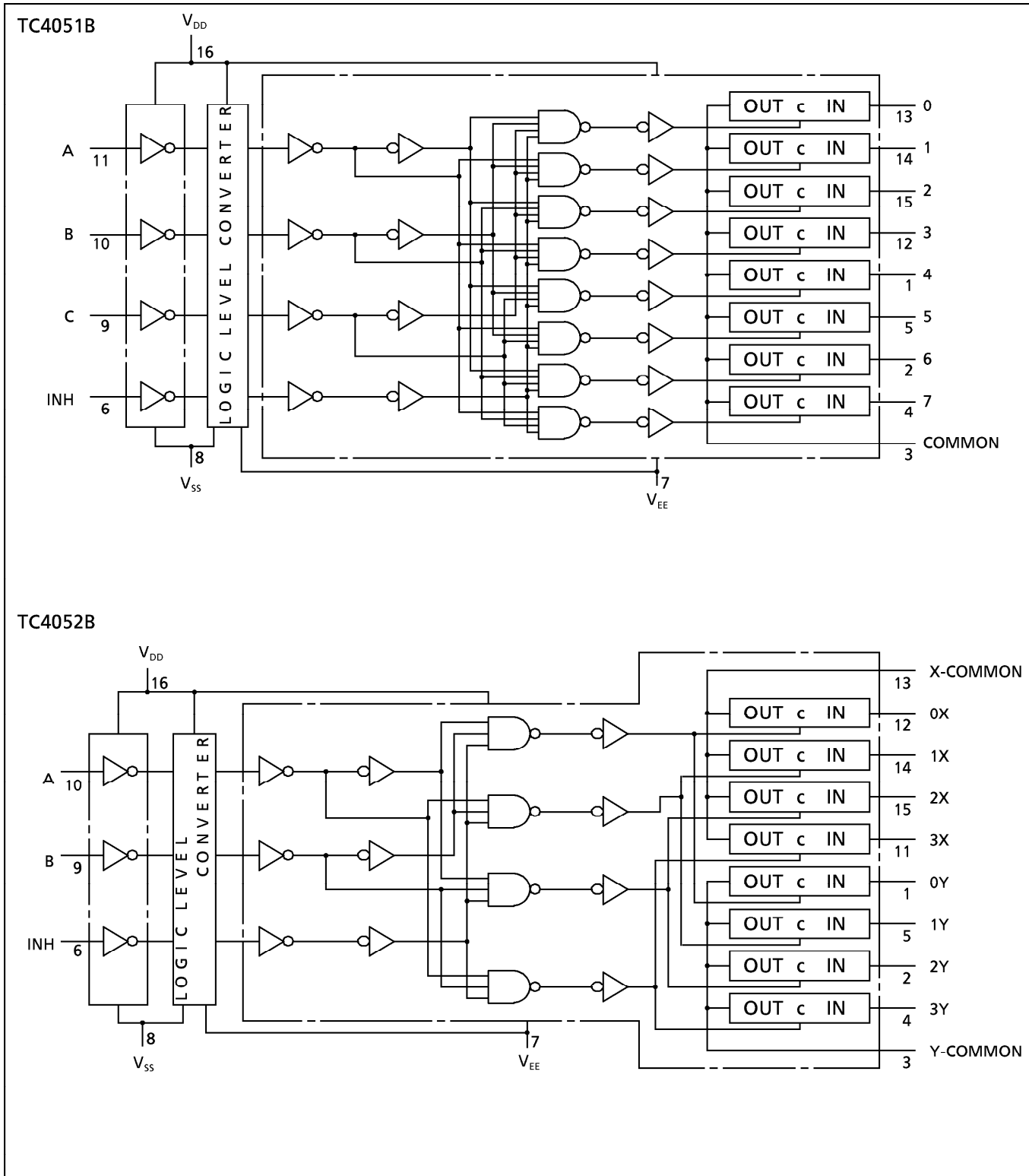

LOGIC DIAGRAM

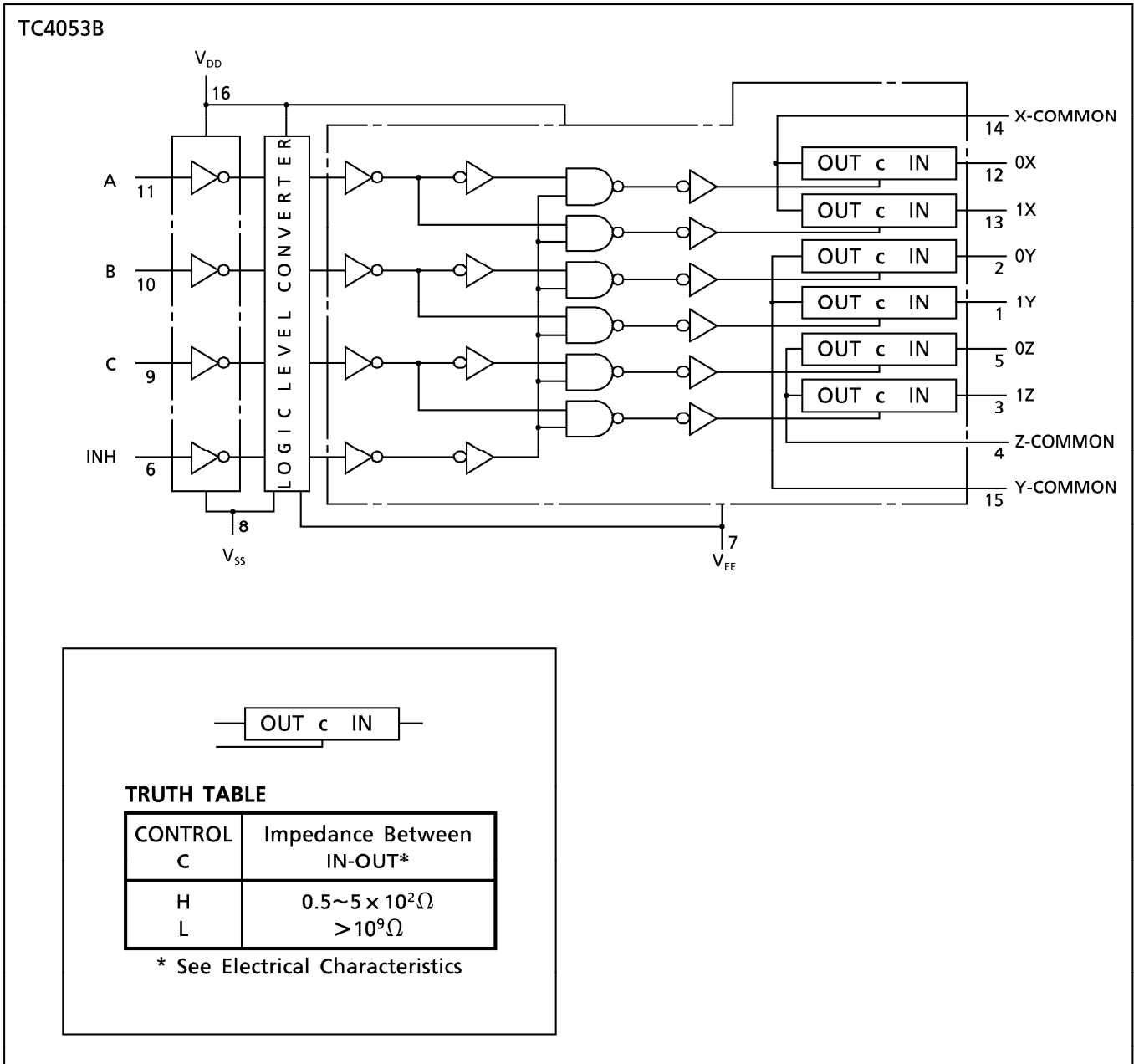



CS8413 CS8414

PIN DESCRIPTIONS: CS8414

		CS8414			
CHANNEL STATUS OUTPUT	C	1 ●	28	VERF	VALIDITY + ERROR FLAG
CS d/FREQ REPORT 1	Cd/F1	2	27	Ce/F2	CS e/FREQ REPORT 2
CS c/FREQ REPORT 0	Cc/F0	3	26	SDATA	SERIAL OUTPUT DATA
CS b/ERROR CONDITION 2	Cb/E2	4	25	ERF	ERROR FLAG
CS a/ERROR CONDITION 1	Ca/E1	5	24	M1	SERIAL PORT MODE SELECT 1
CS $\bar{0}$ /ERROR CONDITION 0	$\bar{C0}/E0$	6	23	M0	SERIAL PORT MODE SELECT 0
DIGITAL POWER	VD+	7	22	VA+	ANALOG POWER
DIGITAL GROUND	DGND	8	21	AGND	ANALOG GROUND
RECEIVE POSITIVE	RXP	9	20	FILT	FILTER
RECEIVE NEGATIVE	RXN	10	19	MCK	MASTER CLOCK
FRAME SYNC	FSYNC	11	18	M2	SERIAL PORT MODE SELECT 2
SERIAL DATA CLOCK	SCK	12	17	M3	SERIAL PORT MODE SELECT 3
CHANNEL SELECT/FCLOCK	CS12/FCK	13	16	SEL	FREQ/CS SELECT
USER DATA OUTPUT	U	14	15	CBL	CS BLOCK START

Power Supply Connections**VD+** - Positive Digital Power, PIN 7.

Positive supply for the digital section. Nominally +5 volts.

VA+ - Positive Analog Power, PIN 22.

Positive supply for the analog section. Nominally +5 volts.

DGND - Digital Ground, PIN 8.

Ground for the digital section. DGND should be connected to same ground as AGND.

AGND - Analog Ground, PIN 21.

Ground for the analog section. AGND should be connected to same ground as DGND.

**CS8413 CS8414**Audio Output Interface**SCK - Serial Clock, PIN 12.**

Serial clock for SDATA pin which can be configured (via the M0, M1, M2, and M3 pins) as an input or output, and can sample data on the rising or falling edge. As an output, SCK will generate 32 clocks for every audio sample. As an input, 32 SCK periods per audio sample must be provided in all normal modes.

FSYNC - Frame Sync, PIN 11.

Delineates the serial data and may indicate the particular channel, left or right, and may be an input or output. The format is based on M0, M1, M2, and M3 pins.

SDATA - Serial Data, PIN 26.

Audio data serial output pin.

M0, M1, M2, M3 - Serial Port Mode Select, PINS 23, 24, 18, 17.

Selects the format of FSYNC and the sample edge of SCK with respect to SDATA. M3 selects between eight normal modes (M3 = 0), and six special modes (M3 = 1).

Control Pins**VERF - Validity + Error Flag, PIN 28.**

A logical OR'ing of the validity bit from the received data and the error flag. May be used by interpolation filters to interpolate through errors.

U - User Bit, PIN 14.

Received user bit serial output port. FSYNC may be used to latch this bit externally. (Except in I²S modes when this pin is updated on the active edge of FSYNC.)

C - Channel Status Output, PIN 1.

Received channel status bit serial output port. FSYNC may be used to latch this bit externally. (Except in I²S modes when this pin is updated on the active edge of FSYNC.)

CBL - Channel Status Block Start, PIN 15.

The channel status block output is high for the first four bytes of channel status and low for the last 20 bytes.

SEL - Select, PIN 16.

Control pin that selects either channel status information (SEL = 1) or error and frequency information (SEL = 0) to be displayed on six of the following pins.



CS8413 CS8414

C0, Ca, Cb, Cc, Cd, Ce - Channel Status Output Bits, PINS 2-6, 27.

These pins are dual function with the 'C' bits selected when SEL is high. Channel status information is displayed for the channel selected by CS12. C0, which is channel status bit 0, defines professional (C0 = 0) or consumer (C0 = 1) mode and further controls the definition of the Ca-Ce pins. These pins are updated with the rising edge of CBL.

CS12 - Channel Select, PIN 13.

This pin is also dual function and is selected by bringing SEL high. CS12 selects sub-frame 1 (when low) or sub-frame 2 (when high) to be displayed by channel status pins C0 and Ca through Ce.

FCK - Frequency Clock, PIN 13.

Frequency Clock input that is enabled by bringing SEL low. FCK is compared to the received clock frequency with the value displayed on F2 through F0. Nominal input value is 6.144 MHz.

E0, E1, E2 - Error Condition, PINS 4-6.

Encoded error information that is enabled by bringing SEL low. The error codes are prioritized and latched so that the error code displayed is the highest level of error since the last clearing of the error pins. Clearing is accomplished by bring SEL high for more than 8 MCK cycles.

F0, F1, F2 - Frequency Reporting Bits, PINS 2-3, 27.

Encoded sample frequency information that is enabled by bringing SEL low. A proper clock on FCK must be input for at least two thirds of a channel status block for these pins to be valid. They are updated three times per block, starting at the block boundary. These pins are invalid when the PLL is out of lock.

ERF - Error Flag, PIN 25.

Signals that an error has occurred while receiving the audio sample currently being read from the serial port. Three errors cause ERF to go high: a parity or biphase coding violation during the current sample, or an out of lock PLL receiver.

Receiver Interface

RXP, RXN - Differential Line Receivers, PINS 9, 10.

RS422 compatible line receivers.

Phase Locked Loop

MCK - Master Clock, PIN 19.

Low jitter clock output of 256 times the received sample frequency.

FILT - Filter, PIN 20.

An external 470Ω resistor and 0.068μF capacitor is required from FILT pin to analog ground.

MITSUBISHI MICROCOMPUTERS

M35012-XXXSP, M35013-XXXSP

SCREEN CHARACTER and PATTERN DISPLAY CONTROLLERS

DESCRIPTION

The M35012-XXXSP and M35013-XXXSP are TV screen display control IC which can be used to display information such as program schedules, the date and messages on the TV screen.

The differences among M35012-XXXSP and M35013-XXXSP are noted below.

The descriptions that follow describe the M35013-XXXSP unless otherwise noted.

Type name	M35012-XXXSP	M35013-XXXSP
Characters available	256	128
Data input	16 bits serial input	8 bits serial input
Exclusion function	Exclusion 1 and 2 function	Exclusion 1 function
CONT7F function	Normal/7F ₁₆ writing mode	Normal/7F ₁₆ writing mode

For M35013-001SP and M35012-001SP that are standard ROM version of M35013-XXXSP and M35012-XXXSP respectively, the I/O polarity of pin and the character pattern are also mentioned.

FEATURES

- Screen composition..... 24 columns X 10 lines
- Number of characters displayed..... 240 (Max.)
- Character composition 12 X 18 dot matrix
- Characters available
 - M35013-XXXSP..... 128 characters
 - M35012-XXXSP..... 256 characters
- Character sizes available ... 4 (horizontal) X 4 (vertical)
- Display locations available
 - Horizontal direction 62 locations
 - Vertical direction..... 64 locations
- Blinking Character units
 - Cycle : approximately 1 second, or approximately 0.5 seconds
 - Duty : 25%, 50%, or 75%
- Data Input
 - M35013-XXXSP..... By the 8-bit serial input function
 - M35012-XXXSP..... By the 16-bit serial input function
- Coloring
 - Background coloring (composite video signal)
- Blanking
 - Total blanking (14 X 18 dots)
 - Border size blanking
 - Character size blanking
- Synchronization signal
 - Composite synchronization signal generation (PAL, NTSC, M-PAL)
- Synchronized separation circuit..... Built-in
- 4 output ports (2 digital lines)
- Oscillation stop function
 - Be possible to stop the oscillation for display and for synchronized signal generation

PIN CONFIGURATION (TOP VIEW)

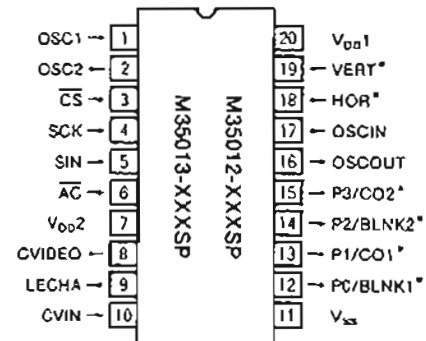

Outline 20P4B

Note : The pins remarked "*" are selectable the input or output polarity when the character ROM masked.

- Exclusion function
 - M35013-XXXSP..... 1
 - M35012-XXXSP..... 2
- Reversed character display function

APPLICATION

TV, VCR, Camcorder

MITSUBISHI MICROCOMPUTERS

M35012-XXXSP, M35013-XXXSP

SCREEN CHARACTER and PATTERN DISPLAY CONTROLLERS

BLOCK DIAGRAM

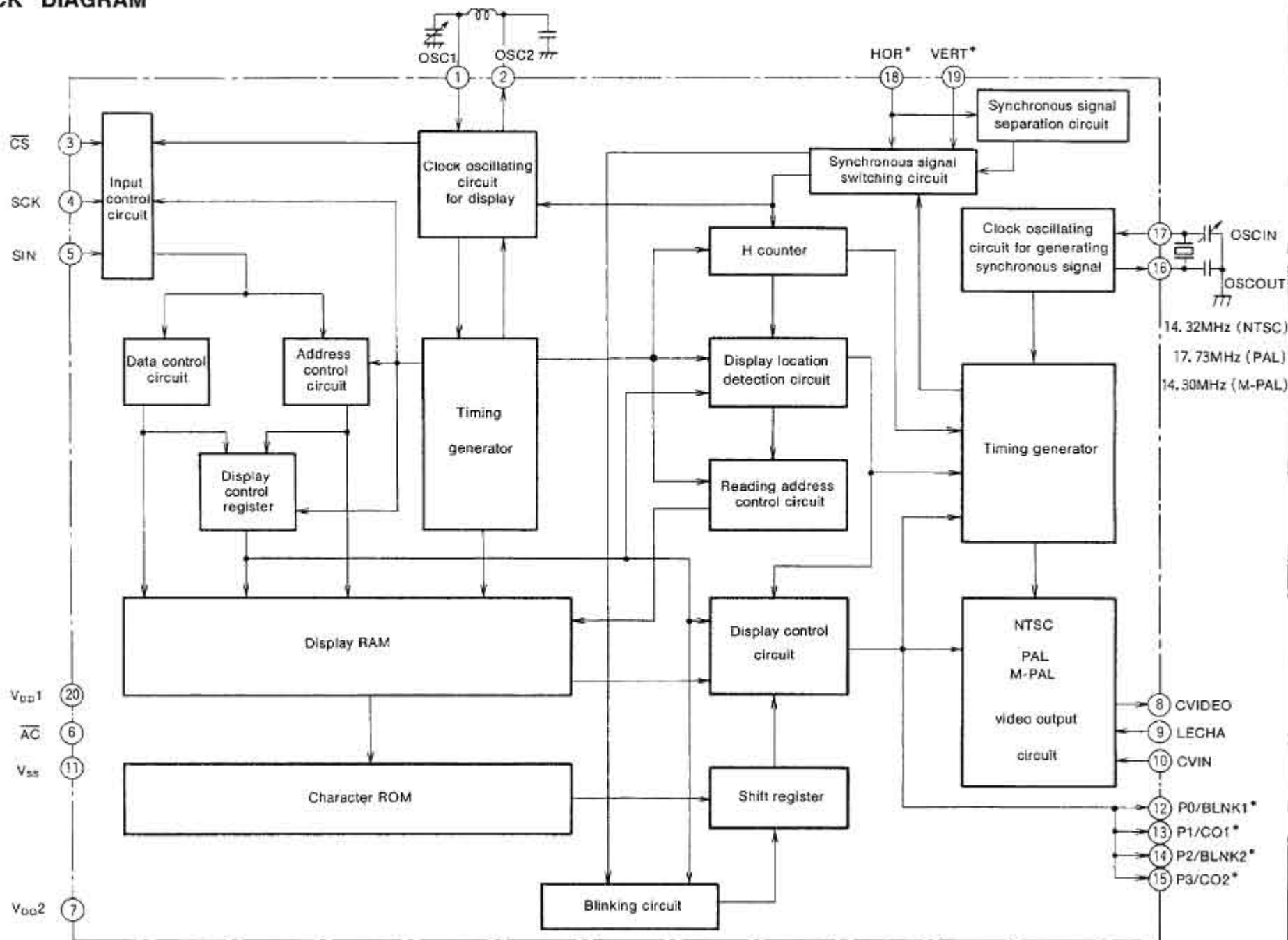

Note: The pins remarked "*" are selectable the input or output polarity when the character ROM masked.

MITSUBISHI MICROCOMPUTERS M35012-XXXSP, M35013-XXXSP

SCREEN CHARACTER and PATTERN DISPLAY CONTROLLERS

PIN DESCRIPTION

Pin Number	Symbol	Pin name	Input /Output	Function
1	OSC1	Pins for attachment of external oscillator circuit	Input	These are the pins for attaching an external display oscillator circuit. The standard oscillation frequency is approximately 7MHz. This oscillation frequency determines the horizontal position of the display on the TV screen and the width of the characters.
2	OSC2		Output	
3	\overline{CS}	Chip select input	Input	This is the chip select pin, and when serial data transmission is being carried out, it goes to "L". Hysteresis input. Includes built-in pull-up resistor.
4	SCK	Serial clock input	Input	When \overline{CS} pin is "L", SIN serial data is taken in when SCK rises. Hysteresis input. Built-in pull-up resistor is included.
5	SIN	Serial data input	Input	This is the pin for serial input of data and addresses for the display control register and the display data memory. Hysteresis input. Includes built-in pull-up resistor.
6	\overline{AC}	Auto-clear input	Input	When "L", this pin resets the internal IC circuit. Hysteresis input. Includes built-in pull-up resistor.
7	V_{DD2}	Power pin	—	Please connect to +5V with the analog circuit power pin.
8	CVIDEO	Composite video signal output	Output	This is the output pin for composite video signals. It outputs 2V _{pp} composite video signals. In superimpose mode, character output etc. is superimposed on the external composite video signals from CVIN.
9	LECHA	Character level input	Input	This is the input pin which determines the "white" character color level in the composite video signal.
10	CVIN	Composite video signal input	Input	This is the input pin for external composite video signals. In superimpose mode, character output etc. is superimposed on these external composite video signals.
11	V_{SS}	Earthing pin	—	Please connect to GND using circuit earthing pin.
12	P0	Port P0 output	Output	This pin can be toggled between port pin output and BLNK1* (character background) signal output. Polarity can be selected when the character ROM is masked.
13	P1	Port P1 output	Output	This pin can be toggled between port pin output and CO1* (character) signal output. Polarity can be selected when the character ROM is masked.
14	P2	Port P2 output	Output	This pin can be toggled between port pin output and BLNK2* (character background) signal output. Polarity can be selected when the character ROM is masked.
15	P3	Port P3 output	Output	This pin can be toggled between port pin output and CO2* (character) signal output. Polarity can be selected when the character ROM is masked.
16	OSCOU	Pins for attachment of external oscillator circuit for synchronization signal generation	Output	These are the pins for attaching an external oscillator circuit for generating the synchronization signal. An oscillation of 14.32MHz is needed for NTSC, 17.73MHz is needed for PAL and 14.30MHz is needed for M-PAL.
17	OSCIN		Input	
18	HOR*	Horizontal synchronization signal input	Input	This pin inputs the horizontal synchronization signal. Hysteresis input. Polarity can be selected when the character ROM is masked.
19	VERT*	Vertical synchronization signal input	Input	This pin inputs the vertical synchronization signal. Hysteresis input. Polarity can be selected when the character ROM is masked.
20	V_{DD1}	Power pin	—	Please connect to +5V with the digital circuit power pin.

Note : The pins remarked "*" are selectable the input or output polarity when the character ROM masked.

NJM2068

LOW-NOISE DUAL OPERATIONAL AMPLIFIER

■ GENERAL DESCRIPTION

The NJM2068 is a high performance, low noise dual operational amplifier. This amplifier features popular pin-out, superior noise performance, and superior total harmonic distortion. This amplifier also features guaranteed noise performance with substantially higher gain-bandwidth product and slew rate, which far exceeds that of the 4558 type amplifier. The specially designed low noise input transistors allow the NJM2068 to be used in very low noise signal processing applications such as audio preamplifiers and servo error amplifier.

■ PACKAGE OUTLINE

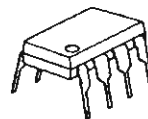

NJM2068D



NJM2068M



NJM2068V

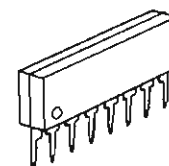

NJM2068L

■ FEATURES

- Operating Voltage ($\pm 4V \sim \pm 18V$)
- Low Total Harmonic Distortion (0.001% typ.)
- Low Noise Voltage (FLAT+JISA, $0.56\mu V$ typ.)
- High Slew Rate ($6V/\mu s$ typ.)
- Unity Gain Bandwidth (27MHz @ $f=10kHz$)
- Package Outline DIP8, DMP8, SIP8, SSOP8
- Bipolar Technology

■ PIN CONFIGURATION

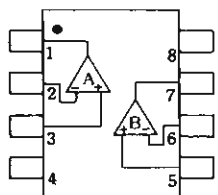

NJM2068D
NJM2068M
NJM2068V

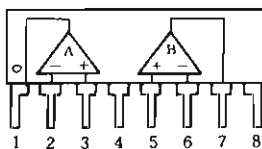

NJM2068L

- PIN FUNCTION**
- 1.A OUTPUT
 - 2.A -INPUT
 - 3.A +INPUT
 - 4.V⁻
 - 5.B +INPUT
 - 6.B -INPUT
 - 7.B OUTPUT
 - 8.V⁺

■ EQUIVALENT CIRCUIT (1/2 Shown)

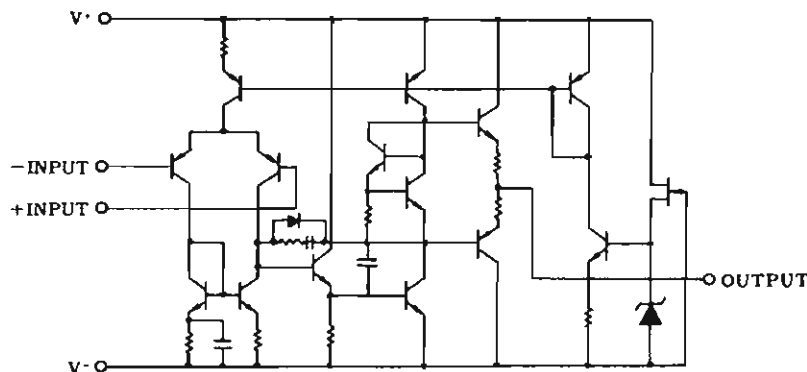

NJM2296

5-INPUT 3-OUTPUT VIDEO SW

GENERAL DESCRIPTION

The NJM2296 is a 5-input 3-output video switch.

Its switches select one from five signals received from VTR, TV, TV GAME and others.

This IC is designed for audio items, such as AV amplifier and receivers, and others

PACKAGE OUTLINE

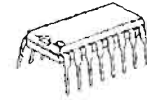

NJM2296D



NJM2296M

FEATURES

- 5-input 3-output
- Operating Voltage ± 4.0 to $\pm 6.5V$
- Operating Current $\pm 31mA$ typ. at $V_{cc} = \pm 5V$
- Crosstalk $-65dB$ typ.
- Internal 6dB Amplifier
- Internal 75Ω Driver
- Bipolar Technology
- Package Outline DIP16, DMP16

BLOCK DIAGRAM

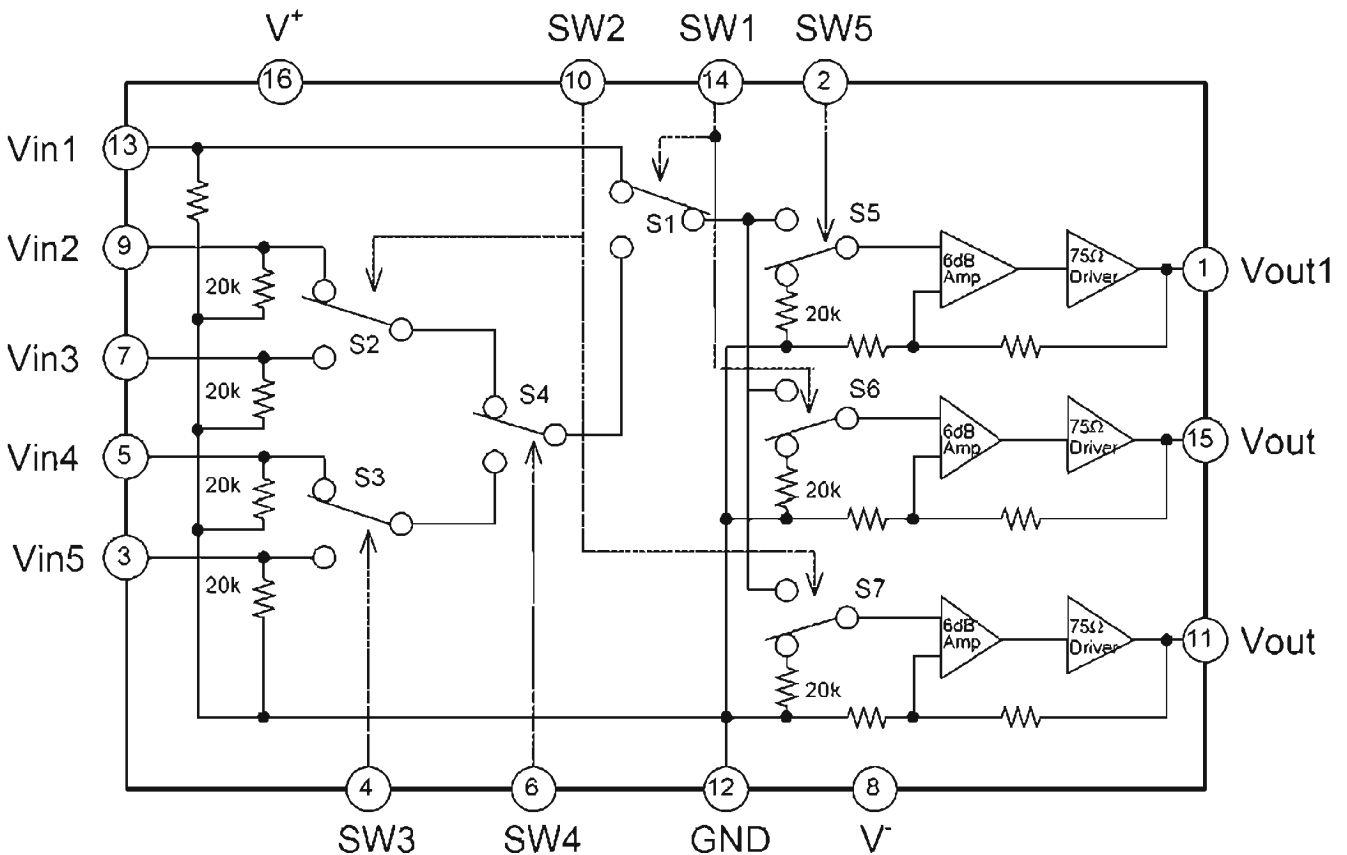

NJM4556A

DUAL HIGH CURRENT OPERATIONAL AMPLIFIER

GENERAL DESCRIPTION

The NJM4556A integrated circuit is a high-gain, high output current dual operational amplifier capable of driving $\pm 70\text{mA}$ into $150\ \Omega$ loads ($\pm 10.5\text{V}$ output voltage), and operating low supply voltage ($V^+/V^- = \pm 2\text{V} \sim$).

The NJM4556A combines many of the fetures of the popular NJM4558 as well as having the capability of driving $150\ \Omega$ loads. In addition, the wide band-width, low noise, high slew rate and low distortion of the NJM4556A make it ideal for many audio, telecommunications and instrumentation applications.

PACKAGE OUTLINE

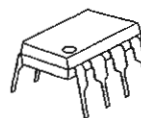

NJM4556AD



NJM4556AM

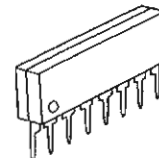

NJM4556AL



NJM4556AV

FEATURES

- Operating Voltage ($\pm 2\text{V} \sim \pm 18\text{V}$)
- High Output Current ($I_o = 70\text{mA}$)
- Slew Rate ($3\text{V}/\mu\text{s}$ typ.)
- Gain Band Width Product (8MHz typ.)
- Package Outline DIP8, DMP8, SIP8, SSOP8
- Bipolar Technology

PIN CONFIGURATION

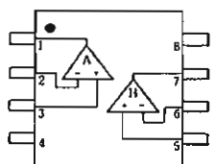

NJM4556AD
NJM4556AM
NJM4556AV

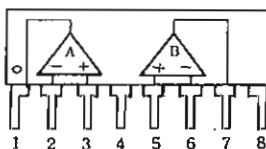

NJM4556AL

PIN FUNCTION

1. A OUTPUT
2. A- INPUT
3. A+ INPUT
4. V^-
5. B+ INPUT
6. B- INPUT
7. B OUTPUT
8. V^+

EQUIVALENT CIRCUIT (1/2 Shown)

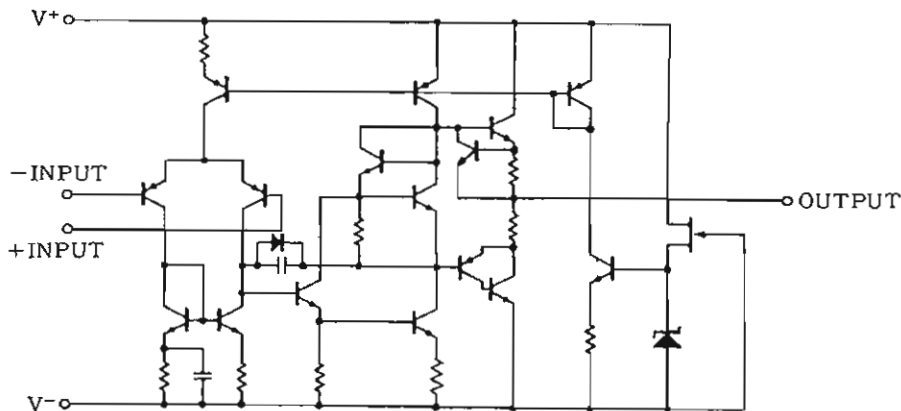

QUARTZ CRYSTAL OSCILLATOR

■ GENERAL DESCRIPTION

The NJU6324 series is a C-MOS quartz crystal oscillator which consists of an oscillation amplifier, 3-stage divider and 3-state output buffer.

The oscillation frequency is as wide as up to 50MHz and the symmetry of 45-55% is realized over full oscillation frequency range.

The oscillation amplifier incorporates feed-back resistance and oscillation capacitors(C_g , C_d), therefore, it requires no external component except quartz crystal.

The 3-stage divider generates f_o , $f_o/2$, $f_o/4$ and $f_o/8$ and only one frequency selected by internal circuits is output

The 3-state output buffer is C-MOS compatible and capable of 10 LSTTL driving.

■ FEATURES

- Operating Voltage -- 3.0~6.0V
- Maximum Oscillation Frequency -- 50MHz
- Low Operating Current
- High Fan-out -- LSTTL 10
- 3-state Output Buffer
- Selected Frequency Output (mask option)
 - Only one frequency out of f_o , $f_o/2$, $f_o/4$ and $f_o/8$ output
- Oscillation Capacitors C_g and C_d on-chip
- Oscillation and/or Output Stand-by Function
- Package Outline -- CHIP/EMP 8
- C-MOS Technology

■ LINE-UP TABLE

Type No.	Output Frequency	C_g	C_d
NJU6324L	f_o	23pF	23pF
NJU6324M	$f_o/2$	23pF	23pF
NJU6324N	$f_o/4$	23pF	23pF
NJU6324U	$f_o/8$	23pF	23pF

■ BLOCK DIAGRAM

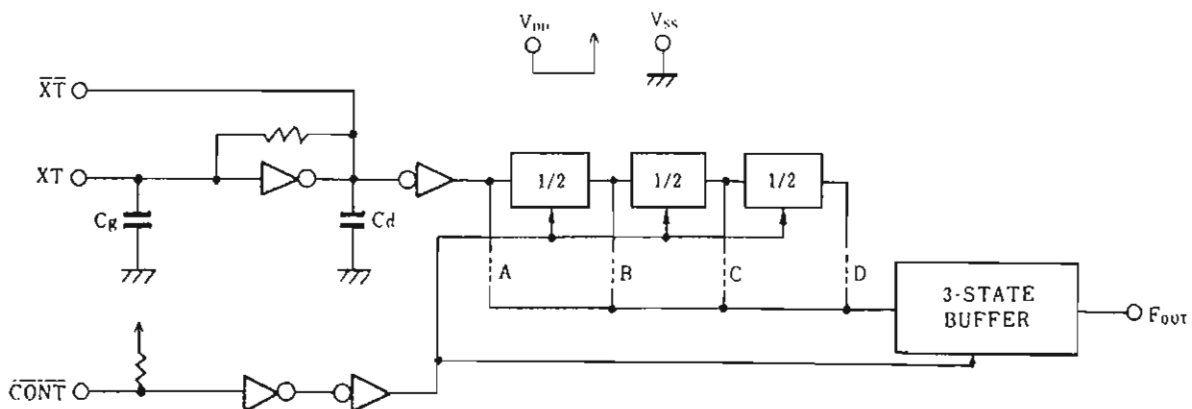

■ PACKAGE OUTLINE



NJU6324XC



NJU6324XE

■ PIN CONFIGURATION/PAD LOCATION

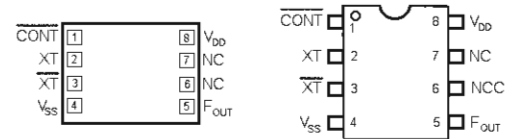

■ COORDINATES

Unit: μm

No.	PAD	X	Y
1	CONT	170	649
2	XT	170	483
3	XT	170	316
4	VSS	170	143
5	FOUT	1094	143
6	NC	-	-
7	NC	1094	462
8	VDD	1094	649

Chip Size : 1.24 X 0.8mm

Chip Thickness : 400 $\mu\text{m} \pm 30 \mu\text{m}$

(Note) No. 6 and 7 terminals are only for package type information. There is No.7 PAD on the chip but no No.6.

TOSHIBA CMOS DIGITAL INTEGRATED CIRCUIT SILICON MONOLITHIC

**TC9162AN, TC9163AN, TC9164AN
TC9162AF, TC9163AF, TC9164AF**

HIGH VOLTAGE ANALOG FUNCTION SWITCH ARRAY

TC9162AN/AF, TC9163AN/AF and TC9164AN/AF are analog switch arrays for high voltage application. By inputting the specified serial data, the analog switches are controlled. As each analog switch is independently controllable, switch of wide use is available.

FEATURES

- Analog switches of 16 circuits are built in, allowing to provide three types according to internal connections.
- Dual power supply of (+) and (-) can be used. In this case the switch select data is operated in a single power supply by the built-in level shifter. As the threshold level of the input inverter is designed low, interface with CMOS microcomputer is easily available.
- As the analog switches are high-voltage (30V) use and have superior linearity of on-resistance, extra low distortion and wide dynamic range can be realized.
- Owing to CMOS structure current consumption is low.
- Package is shrunk DIP 28 PIN.

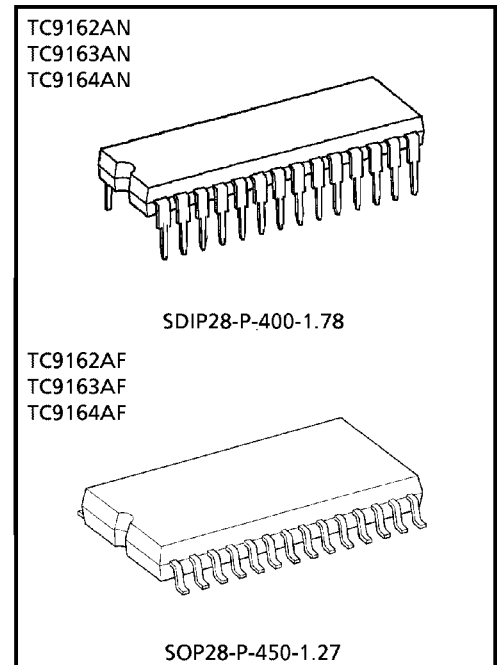

Weight
SDIP28-P-400-1.78 : 2.2g (Typ.)
SOP28-P-450-1.27 : 0.8g (Typ.)

BLOCK DIAGRAM

TC9162AN/AF

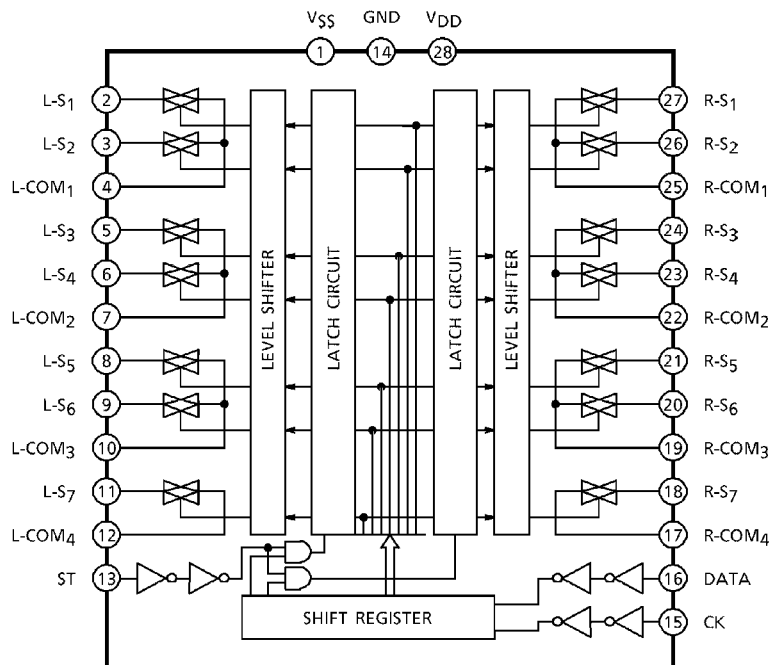

TC9163AN / AF

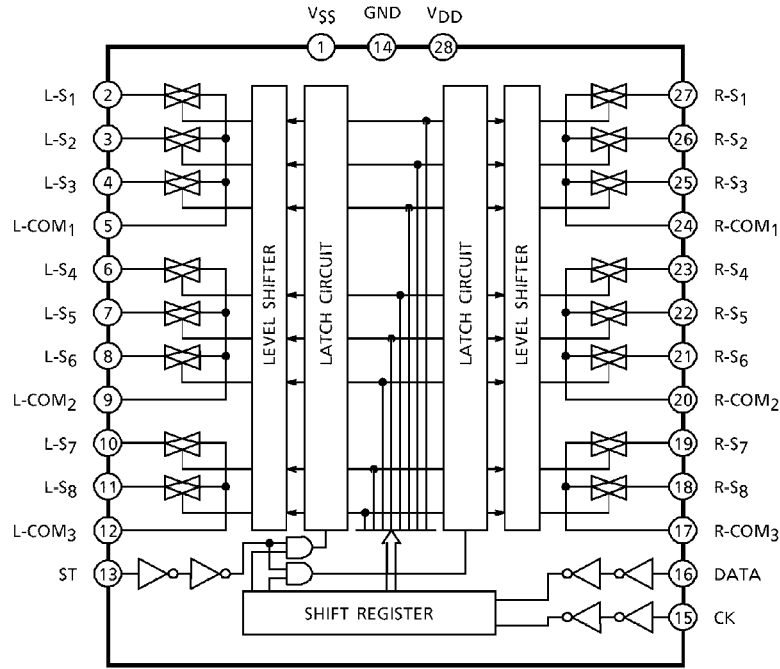

TC9164AN / AF

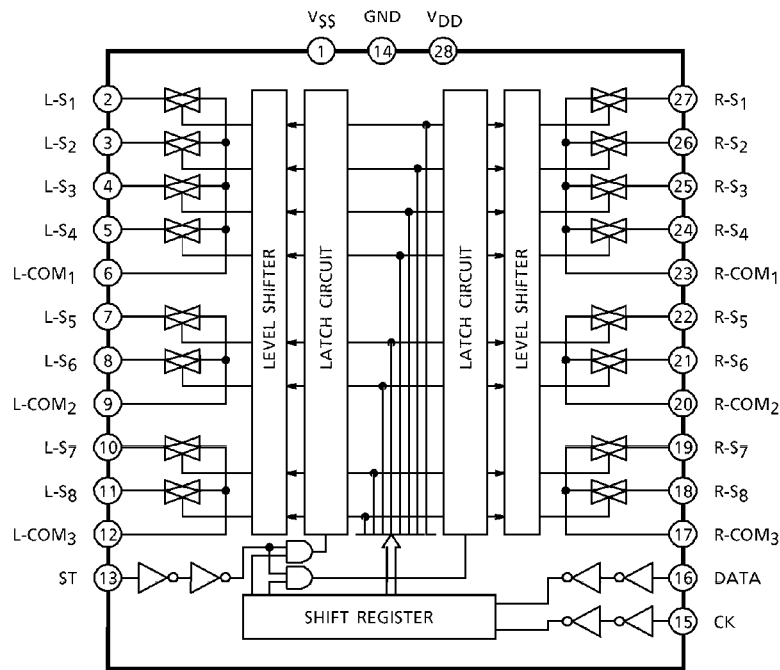

PIN CONNECTION (TOP VIEW)

TC9162AN / AF

VSS	1	28	VDD
L-S1	2	27	R-S1
L-S2	3	26	R-S2
L-COM1	4	25	R-COM1
L-S3	5	24	R-S3
L-S4	6	23	R-S4
L-COM2	7	22	R-COM2
L-S5	8	21	R-S5
L-S6	9	20	R-S6
L-COM3	10	19	R-COM3
L-S7	11	18	R-S7
L-COM4	12	17	R-COM4
ST	13	16	DATA
GND	14	15	CK

TC9163AN / AF

VSS	1	28	VDD
L-S1	2	27	R-S1
L-S2	3	26	R-S2
L-S3	4	25	R-S3
L-COM1	5	24	R-COM1
L-S4	6	23	R-S4
L-S5	7	22	R-S5
L-S6	8	21	R-S6
L-COM2	9	20	R-COM2
L-S7	10	19	R-S7
L-S8	11	18	R-S8
L-COM3	12	17	R-COM3
ST	13	16	DATA
GND	14	15	CK

TC9164AN / AF

VSS	1	28	VDD
L-S1	2	27	R-S1
L-S2	3	26	R-S2
L-S3	4	25	R-S3
L-S4	5	24	R-S4
L-COM1	6	23	R-COM1
L-S5	7	22	R-S5
L-S6	8	21	R-S6
L-COM2	9	20	R-COM2
L-S7	10	19	R-S7
L-S8	11	18	R-S8
L-COM3	12	17	R-COM3
ST	13	16	DATA
GND	14	15	CK



November 1992
Revised April 1999

74VHC244

Octal Buffer/Line Driver with 3-STATE Outputs

General Description

The VHC244 is an advanced high speed CMOS octal bus buffer fabricated with silicon gate CMOS technology. It achieves high speed operation similar to equivalent Bipolar Schottky TTL while maintaining the CMOS low power dissipation. The VHC244 is a non-inverting 3-STATE buffer having two active-LOW output enables. These devices are designed to be used as 3-STATE memory address drivers, clock drivers, and bus oriented transmitter/receivers.

An input protection circuit ensures that 0V to 7V can be applied to the input pins without regard to the supply voltage. This device can be used to interface 5V to 3V systems and two supply systems such as battery back up. This cir-

cuit prevents device destruction due to mismatched supply and input voltages.

Features

- High Speed: $t_{PD} = 3.9\text{ns}$ (typ) at $V_{CC} = 5\text{V}$
- High noise immunity: $V_{NIH} = V_{NIL} = 28\% V_{CC}$ (min)
- Power down protection is provided on all inputs
- Low noise: $V_{OLP} = 0.6\text{V}$ (typ)
- Low power dissipation: $I_{CC} = 4\ \mu\text{A}$ (max) @ $T_A = 25^\circ\text{C}$
- Pin and function compatible with 74HC244

Ordering Code:

Order Number	Package Number	Package Description
74VHC244M	M20B	20-Lead Small Outline Integrated Circuit (SOIC), JEDEC MS-013, 0.300" Wide
74VHC244SJ	M20D	20-Lead Small Outline Package (SOP), EIAJ TYPE II, 5.3mm Wide
74VHC244MTC	MTC20	20-Lead Thin Shrink Small Outline Package (TSSOP), JEDEC MO-153, 4.4mm Wide
74VHC244N	N20A	20-Lead Plastic Dual-In-Line Package (PDIP), JEDEC MS-001, 0.300" Wide

Surface mount packages are also available on Tape and Reel. Specify by appending the suffix letter "X" to the ordering code.

Logic Symbol

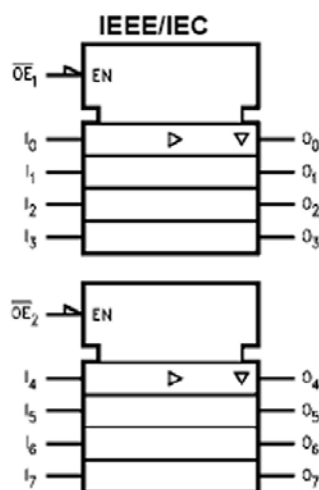

Connection Diagram

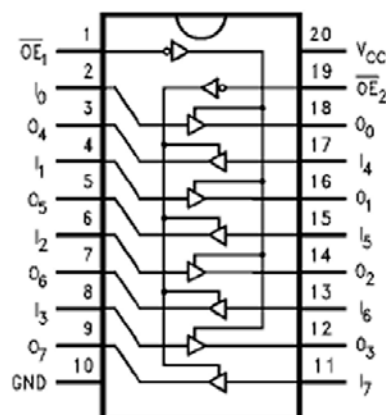

Pin Descriptions

Pin Names	Description
$\overline{OE}_1, \overline{OE}_2$	3-STATE Output Enable Inputs
I_0-I_7	Inputs
O_0-O_7	3-STATE Outputs

Truth Tables

Inputs		Outputs (Pins 12, 14, 16, 18)
\overline{OE}_1	I_n	
L	L	L
L	H	H
H	X	Z

Inputs		Outputs (Pins 3, 5, 7, 9)
\overline{OE}_2	I_n	
L	L	L
L	H	H
H	X	Z

H = HIGH Voltage Level
 L = LOW Voltage Level
 I = Immaterial
 Z = High Impedance

TC9273N

CMOS Digital IC

BLOCK DIAGRAM

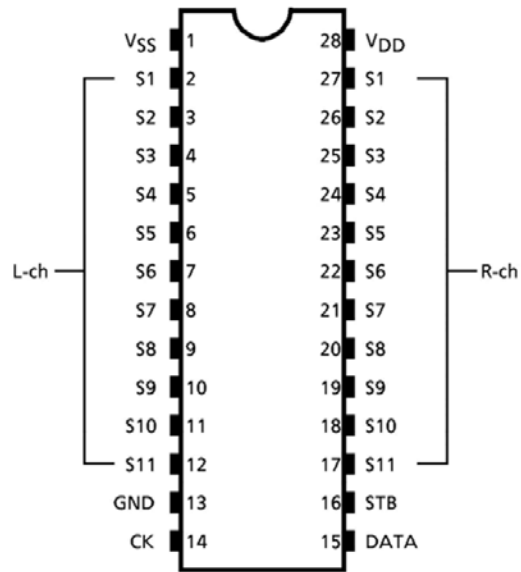
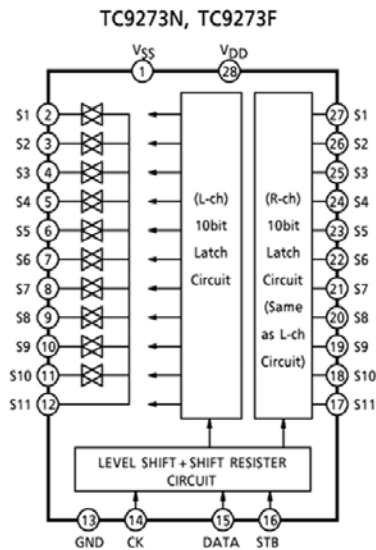

PIN FUNCTION (Left channel / right channel)

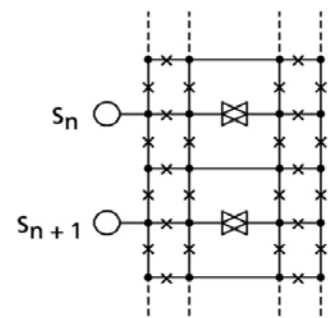
PIN No.			SYMBOL	PIN NAME	FUNCTION AND OPERATION	NOTE
TC9273N / F	TC9274N	TC9274F				
1	1	40	V _{SS}	Negative power supply pin	Dual power supply $V_{DD} = 8.0 \sim 17V$ $GND = 0V$ $V_{SS} = -8.0 \sim -17V$	—
13	20	16	GND	Digital ground pin		
28	42	38	V _{DD}	Positive power supply pin		
2 / 27	2 / 41	41 / 37	S1	Input / output pins	Analog switch input pins.  × : Aluminum mask switch. ● : Open or closed can be specified. Connection for right and left channels can be different.	—
3 / 26	3 / 40	42 / 36	S2			
4 / 25	4 / 39	43 / 35	S3			
5 / 24	5 / 38	44 / 34	S4			
6 / 23	6 / 37	1 / 33	S5			
7 / 22	7 / 36	2 / 32	S6			
8 / 21	8 / 35	3 / 31	S7			
9 / 20	9 / 34	4 / 30	S8			
10 / 19	10 / 33	5 / 29	S9			
11 / 18	11 / 32	6 / 28	S10			
—	13 / 30	8 / 26	S12			
—	14 / 29	9 / 25	S13			
—	15 / 28	10 / 24	S14			
—	16 / 27	11 / 23	S15			
—	17 / 26	12 / 22	S16			
—	18 / 25	13 / 21	S17			
—	19 / 24	14 / 20	S18			
—	—	17 / 39	NC			
14	21	16	CK	Clock input pin	Clock input for data transfer	Low threshold value input pins
15	22	18	DATA	Data input pin	Serial data input for setting switches	
16	23	19	STB	Strobe input pin	Strobe input for data writing	

TOSHIBA**TC9482N/F**

TOSHIBA CMOS DIGITAL INTEGRATED CIRCUIT SILICON MONOLITHIC

TC9482N, TC9482F

SYSTEM ELECTRONIC VOLUME CONTROL

The TC9482N and TC9482F are six-channel electronic volume control ICs developed for Hi-Fi audio equipment. Since all six channels can be individually controlled, the devices are optimum for audio equipment with multiple outputs.

FEATURES

- Sound volume can be controlled in 97 steps from 0 to -95dB or up to an infinite level in 1dB increments.
- Incorporating six channels of volume control circuits, the device allows independent volume control.
- Can operate with a single or dual power supplies.
- Can control up to 4 chips on the same bus by using chip select input.
- Built-in interface for 5-V microcomputers.
- Thanks to its polysilicon resistor, the device allows you to configure a low-distortion, high-performance volume control system.
- Two packages supported: 28-pin shrink DIP and 28-pin flat package.

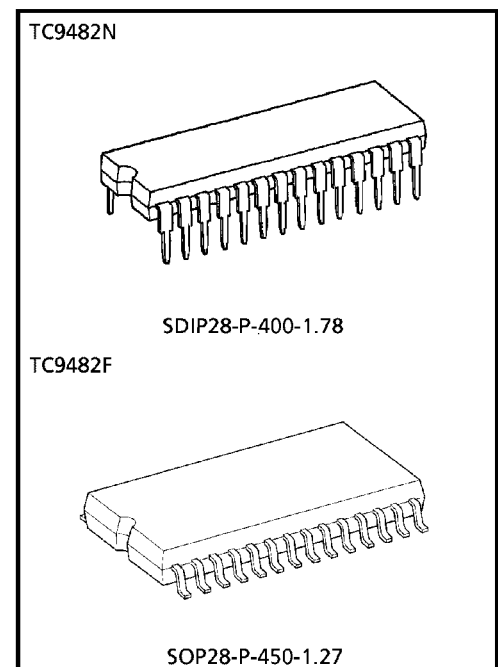

Weight

SDIP28-P-400-1.78 : 2.2 g (Typ.)
 SOP28-P-450-1.27 : 0.8 g (Typ.)

PIN CONNECTIONS

VSS	1	28	VDD
NC	2	27	TEST
L-OUTA	3	26	R-OUTA
L-INA	4	25	R-INA
L-A-GNDA	5	24	R-A-GNDA
L-OUTB	6	23	R-OUTB
L-INB	7	22	R-INB
L-A-GNDB	8	21	R-A-GNDB
L-OUTC	9	20	R-OUTC
L-INC	10	19	R-INC
L-A-GNDC	11	18	R-A-GNDC
CS1	12	17	CS2
GND	13	16	STB
CK	14	15	DATA

BLOCK DIAGRAM

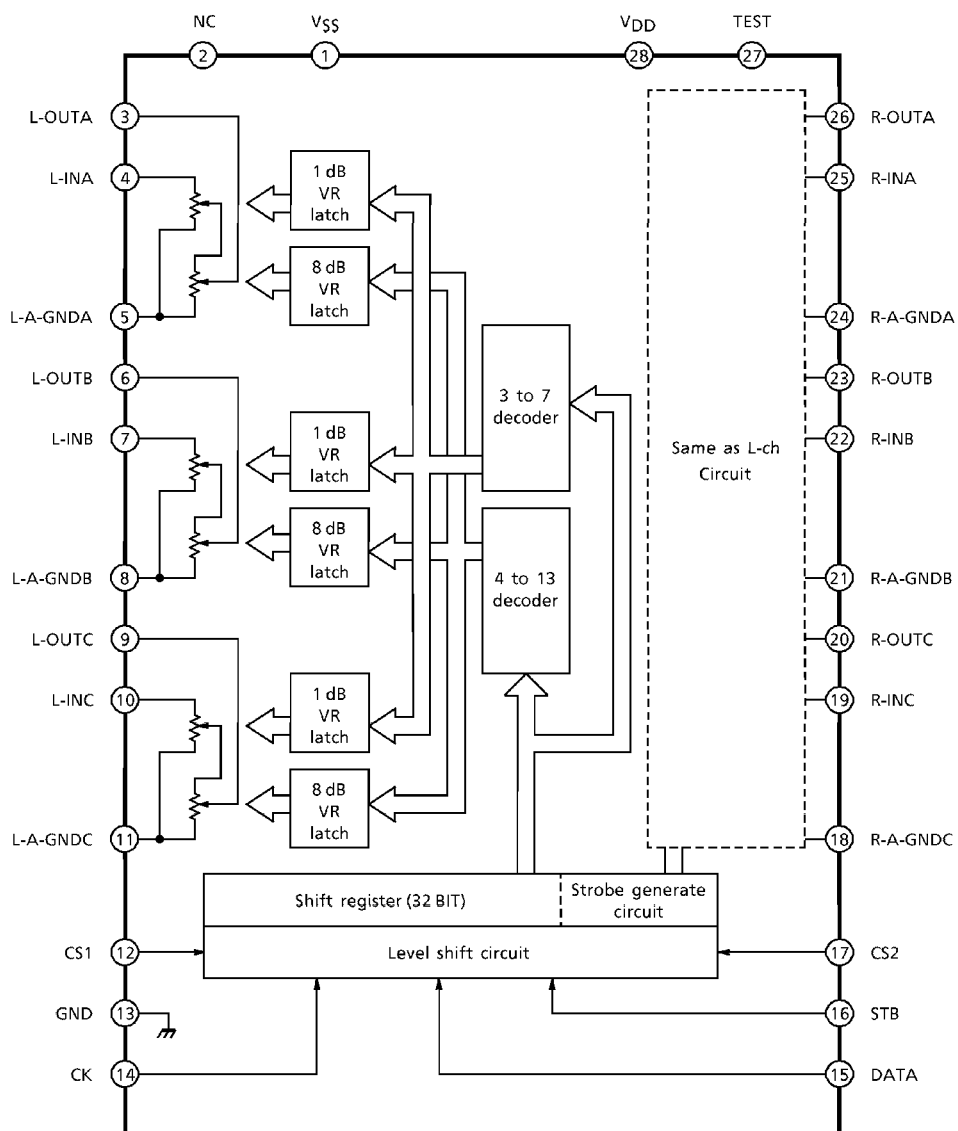

3-Terminal 1.5A Negative Adjustment Regulator IC

KA337

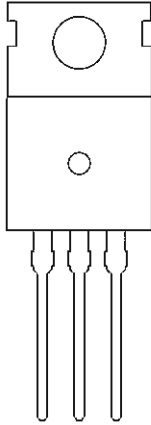

- 1. Adj.
- 2. Input
- 3. Output

Low Saturation Voltage Type 3-Pin Regulator IC

BA033T

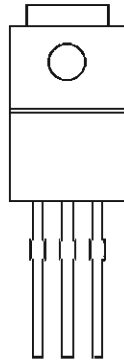

- 1 Vcc
- 2 Ground
- 3 Out

Photocoupler IC

PC-17T1

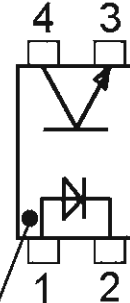

Anode Mark

POSITIVE REGULATORS VARIOUS STYLES 7805, 7815

SOT-89

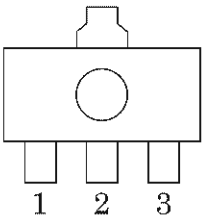

- 1. OUT
- 2. GND
- 3. IN

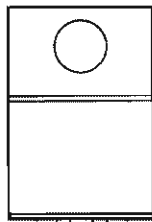

- 1. IN
- 2. GROUND
- 3. OUT

SO-8 Plastic (M)
(Narrow Body)

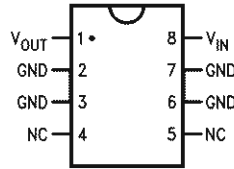

Top View

(TO-92)
Plastic Package (Z)

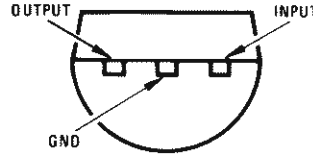

Bottom View

TO-252

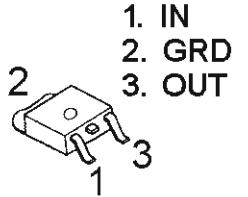

- 1. IN
- 2. GRD
- 3. OUT

NEGATIVE REGULATORS VARIOUS STYLES 7905, 7915

SO-8 Plastic (Narrow Body)

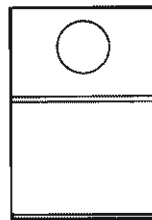

- 1. GROUND
- 2. IN
- 3. OUT

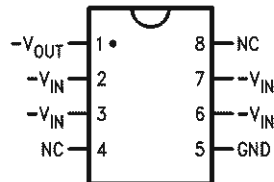

Top View

TO-92 Plastic Package (Z)

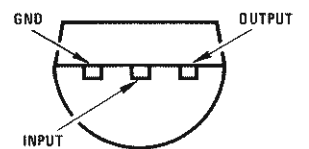

Bottom View

Silicon Transistor

2SA1859 PNP
2SC4883 NPN

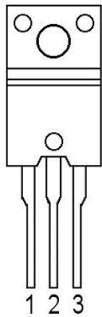

1 Base
2 Collector
3 Emitter

2SA1943
2SC5200

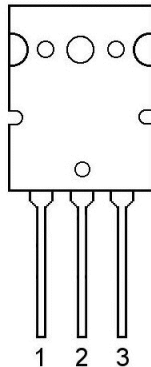

1 Base
2 Collector (Heat Sink)
3 Emitter

Silicon Transistor

2SA1986, 2SA1941, 2SB1560 PNP
2SC5198, 2SC5358, 2SD2390 NPN

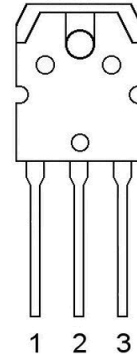

1 Base
2 Collector (Heat Sink)
3 Emitter

KTC1027
KTC3206

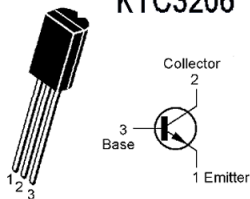

KRC107
KTA1268
KTA1266
KTA1023
KTA1024

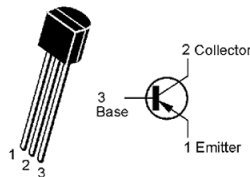

EPITAXIAL PLANAR TRANSISTOR

KTC3200
KTC2874
KTC3198
KRA107M PNP
2SA1145 PNP
2SA1370

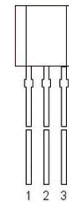

1 Emitter
2 Collector
3 Base

Silicon Transistor

2SA1740S
2SC1740S
DTA114TSA
2SA933AS

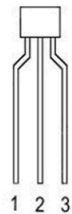

1 Emitter
2 Collector
3 Base

MPSA06

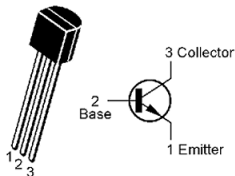

MPSA56

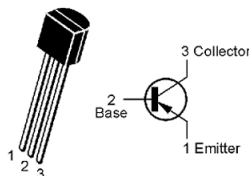

DTA114YSA
DTC114YSA NPN

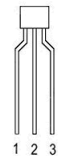

1) Ground
2) In
3) Out

KTD1302

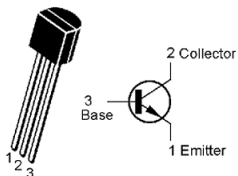

2SA1360
2SC3423

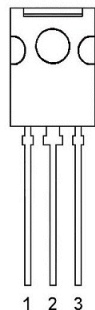

1. EMITTER
2. COLLECTOR
3. BASE

KRA107S PNP
KTD1304 NPN
KRC110S NPN
KRC111S NPN
DTC114TKA NPN
DTC114YKA NPN

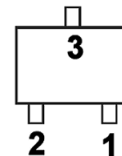

1) Emitter
2) Base
3) Collector

DTA114YKA

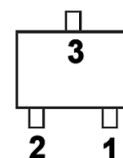

1) Ground
2) In
3) Out

Silicon NPN Transistor

DTC114TSA



1 Emitter
2 Collector
3 Base

2SC4137



1. Emitter
2. Collector
3. Base

SCHEMATIC DIAGRAM

NO	DATE	POS.	CONTENTS	NO	DATE	POS.	CONTENTS
			AVR320				harman/kardon

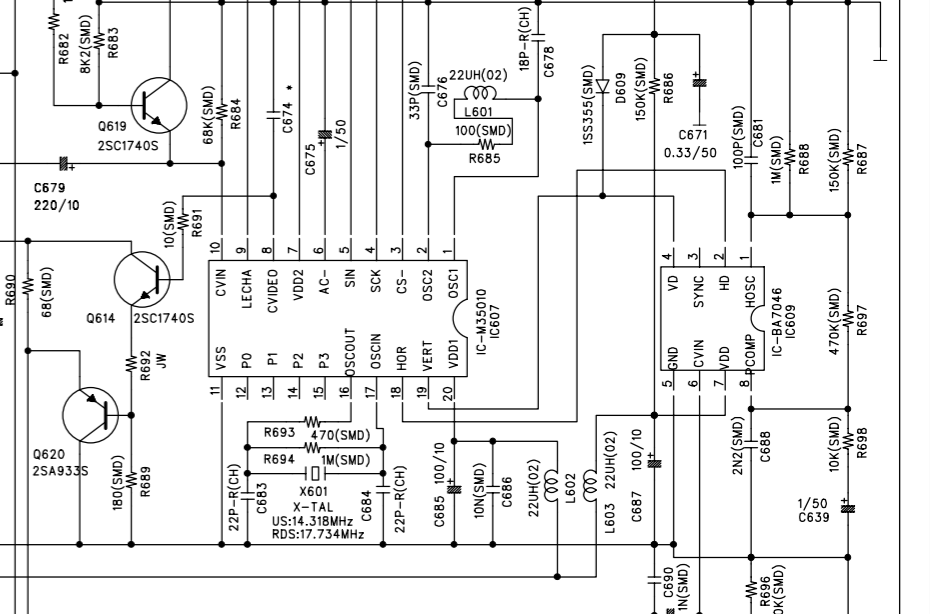
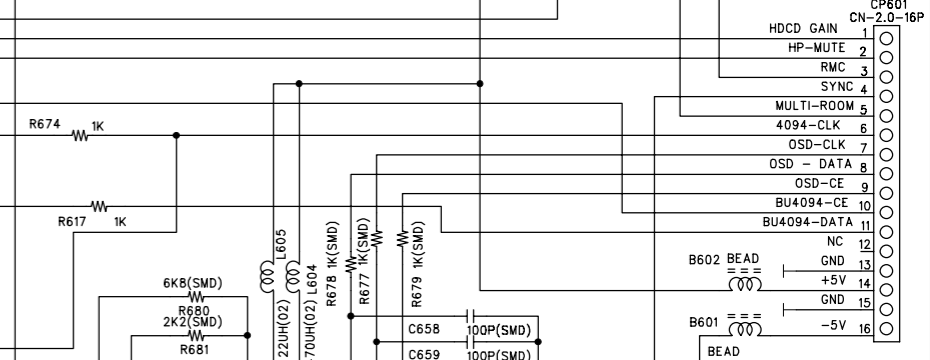
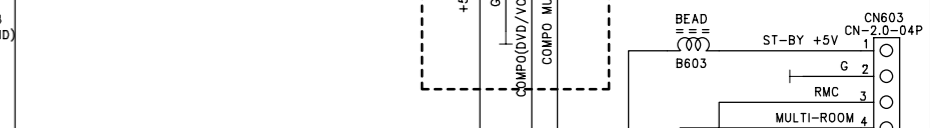
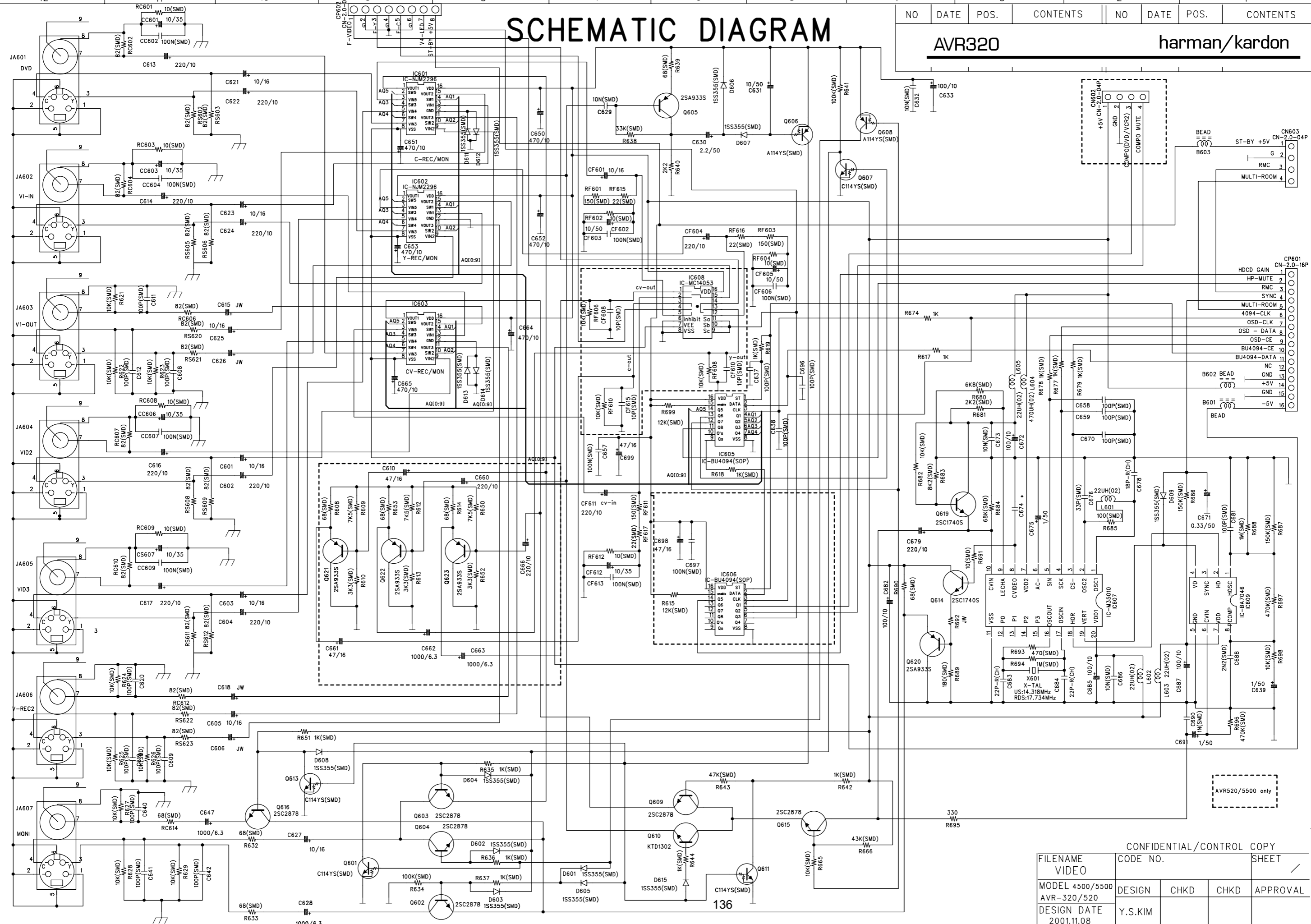

CONFIDENTIAL/CONTROL COPY				
FILENAME	CODE NO.	SHEET		
VIDEO		/	/	A
MODEL 4500/5500 AVR-320/520	DESIGN	CHKD	CHKD	APPROVAL
DESIGN DATE 2001.11.08	Y.S.KIM			

SCHEMATIC

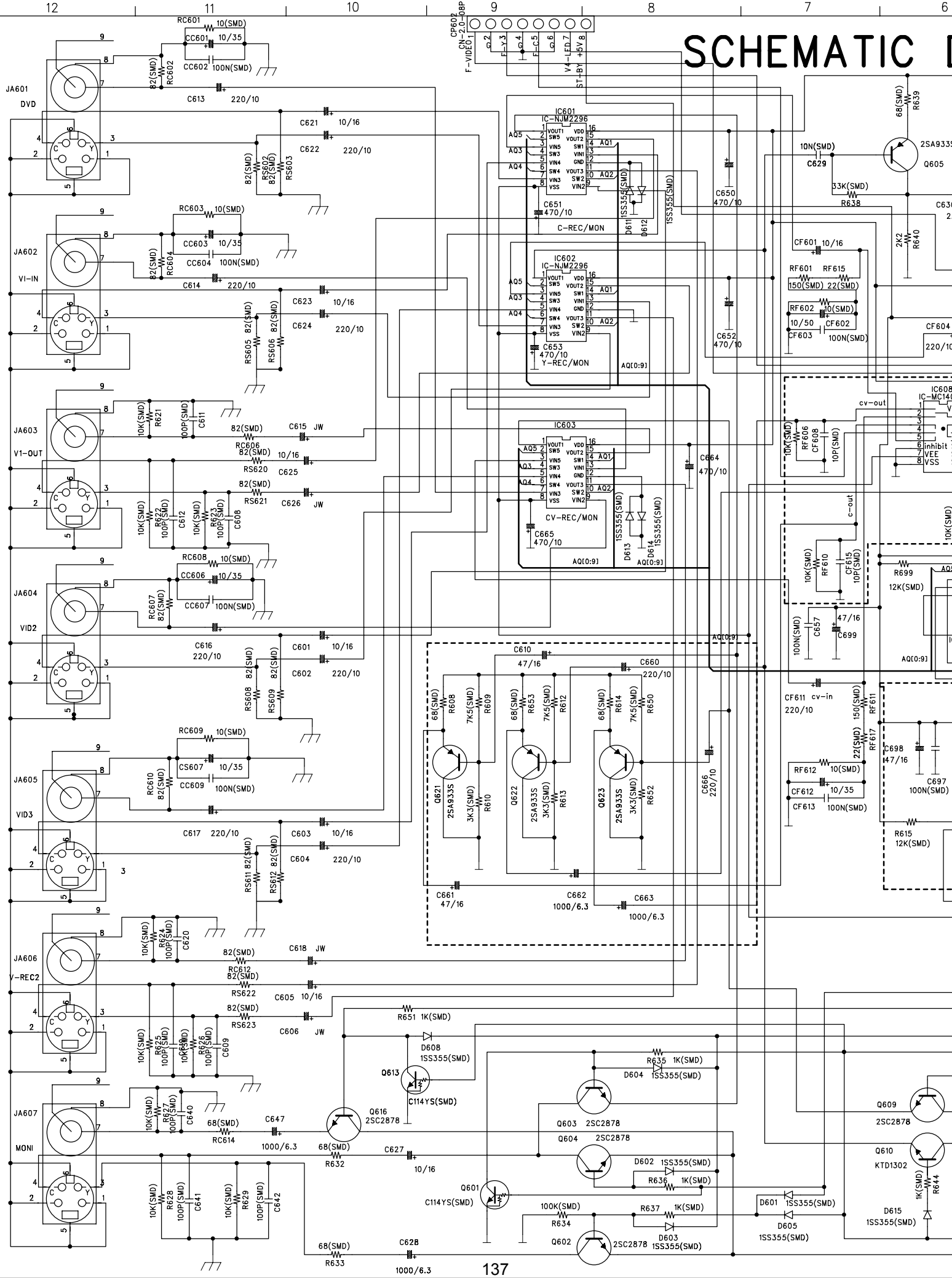

DIAGRAM

NO	DATE	POS.	CONTENTS	NO	DATE	POS.	CONTENTS
----	------	------	----------	----	------	------	----------

AVR320

harman/kardon

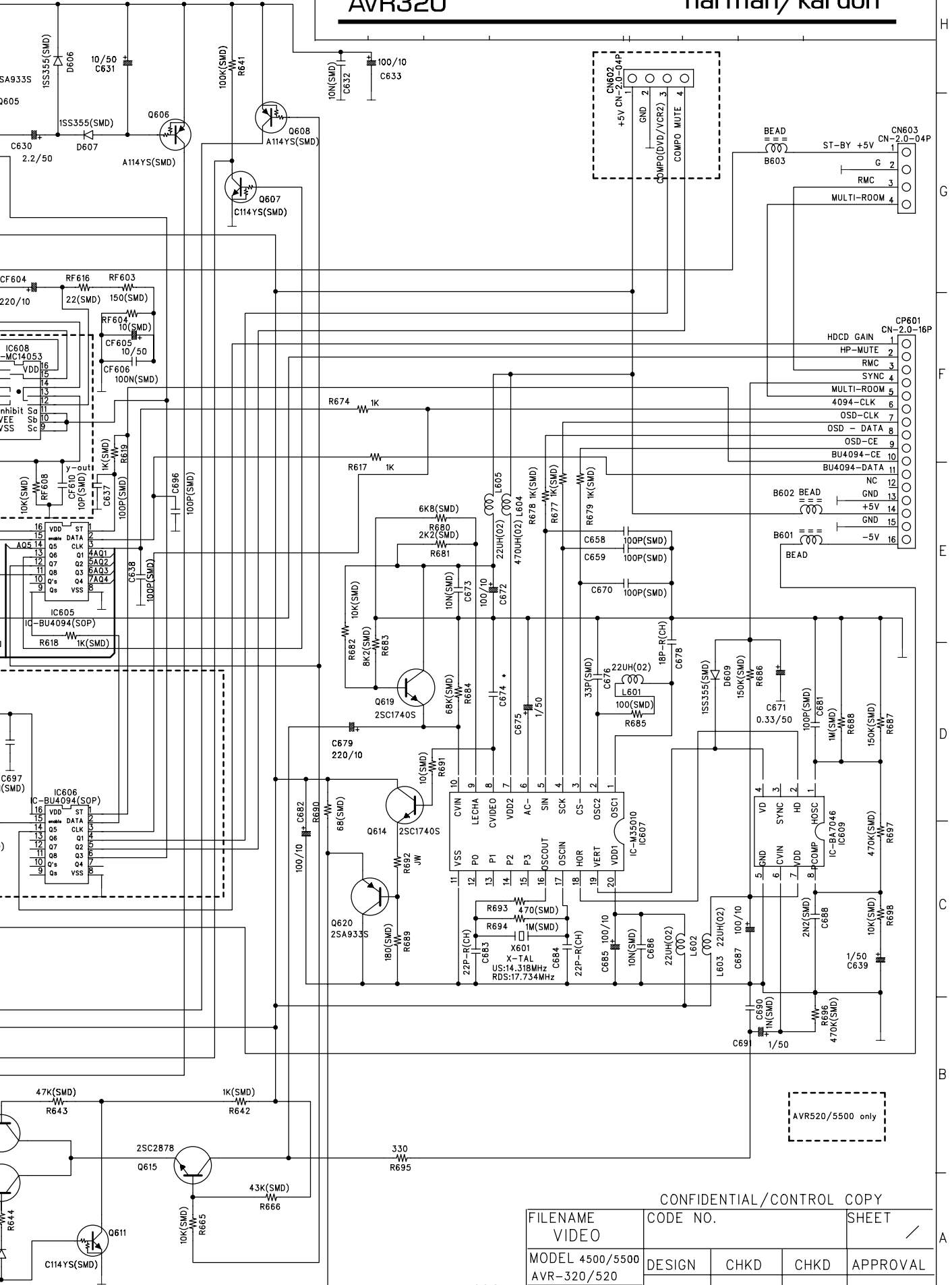

CONFIDENTIAL/CONTROL COPY

FILENAME VIDEO	CODE NO.	SHEET /		
MODEL 4500/5500 AVR-320/520	DESIGN	CHKD	CHKD	APPROVAL
DESIGN DATE 2001.11.08	Y.S.KIM			

SCHEMATIC DIAGRAM

AVR320

harman/kardon

IN RECORD	APPROVED:	DATE:

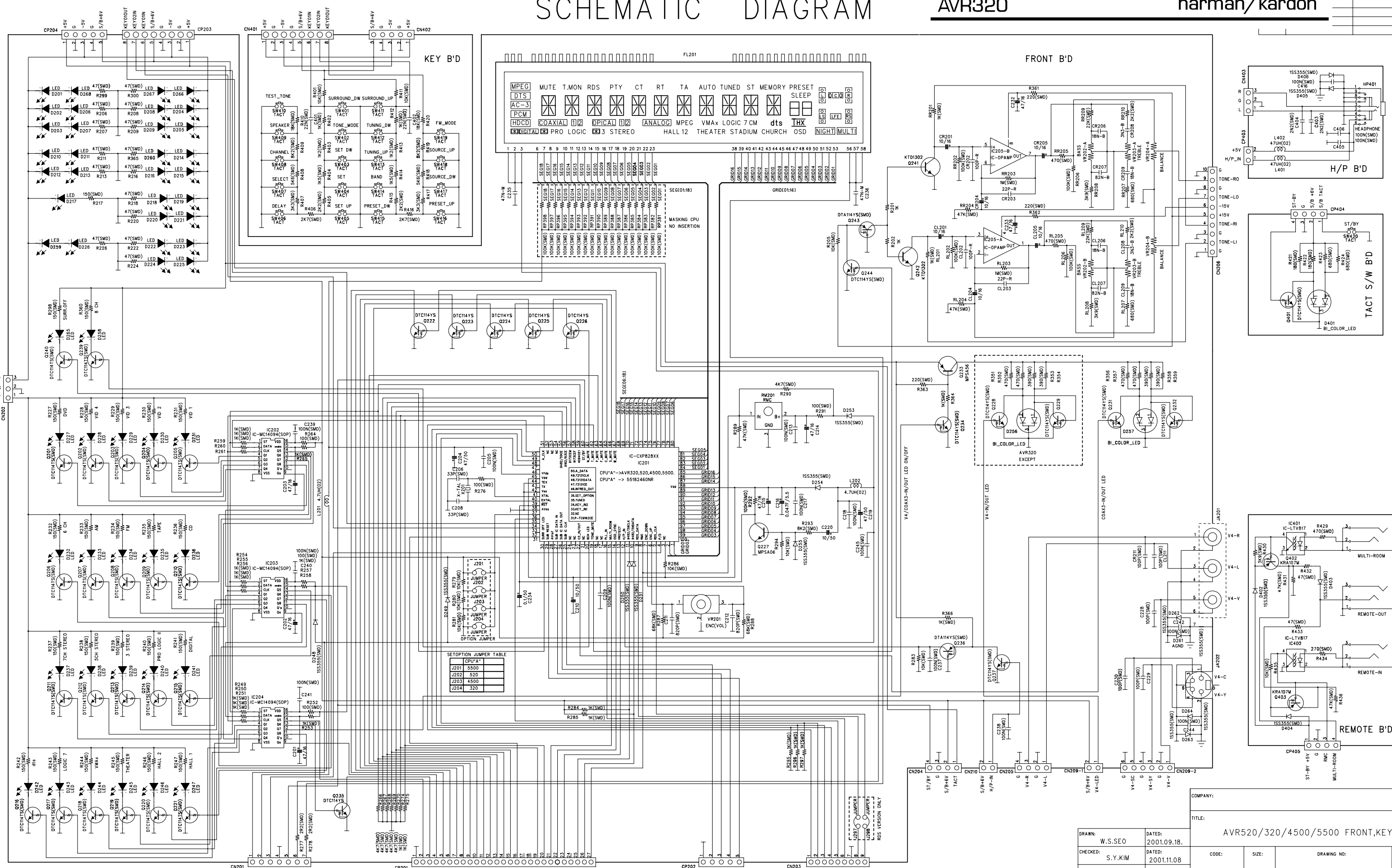

SCHEMATIC

D

C

B

A

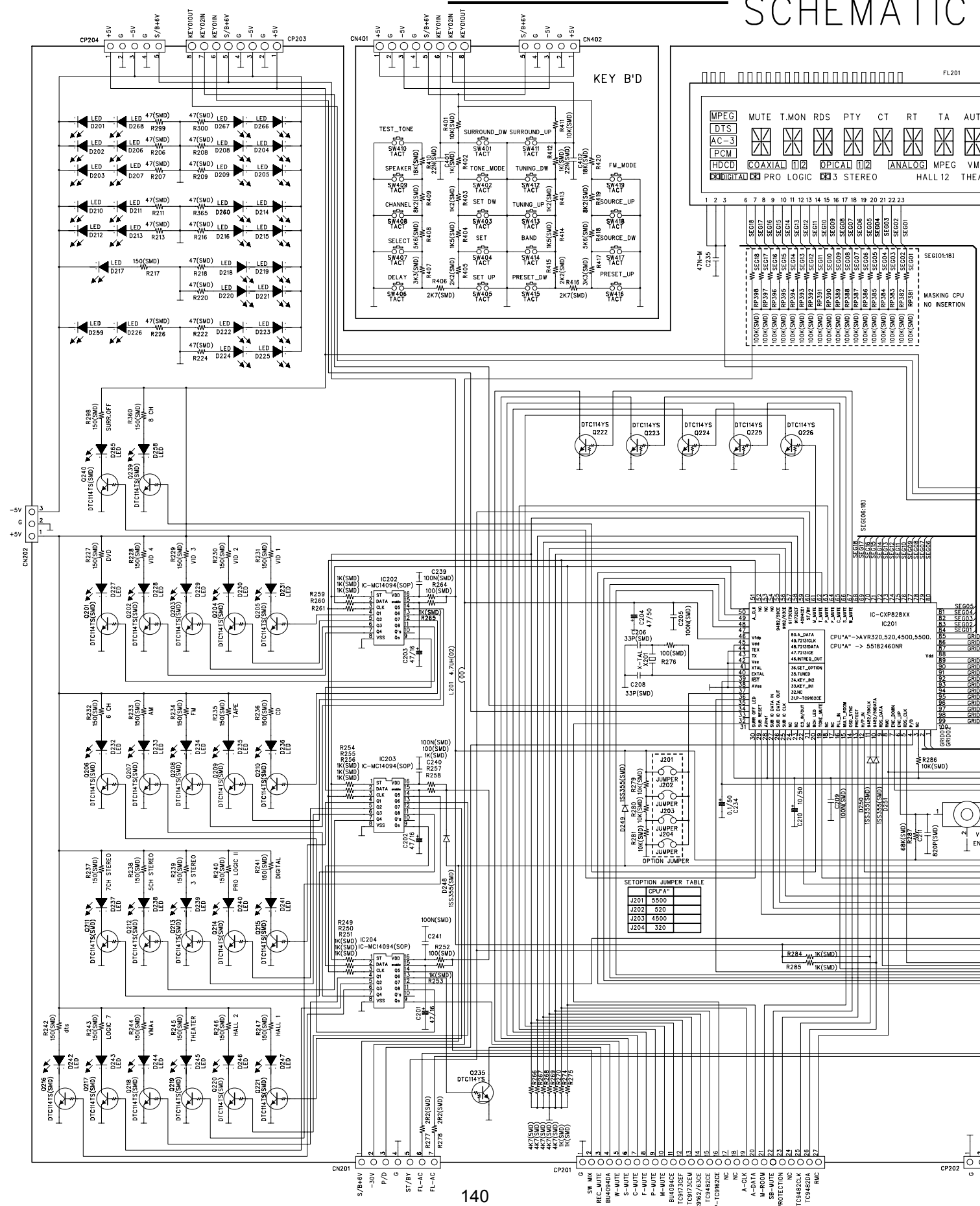

KEY B'D

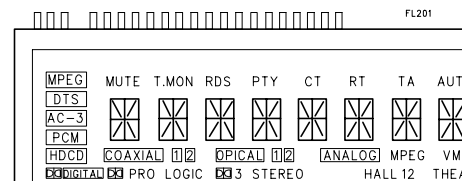

SETOPTION JUMPER TABLE

J201	CPU1A
J202	5500
J203	4500
J204	320

C DIAGRAM

AVR320

harman/kardon

APPROVED:	DATE:

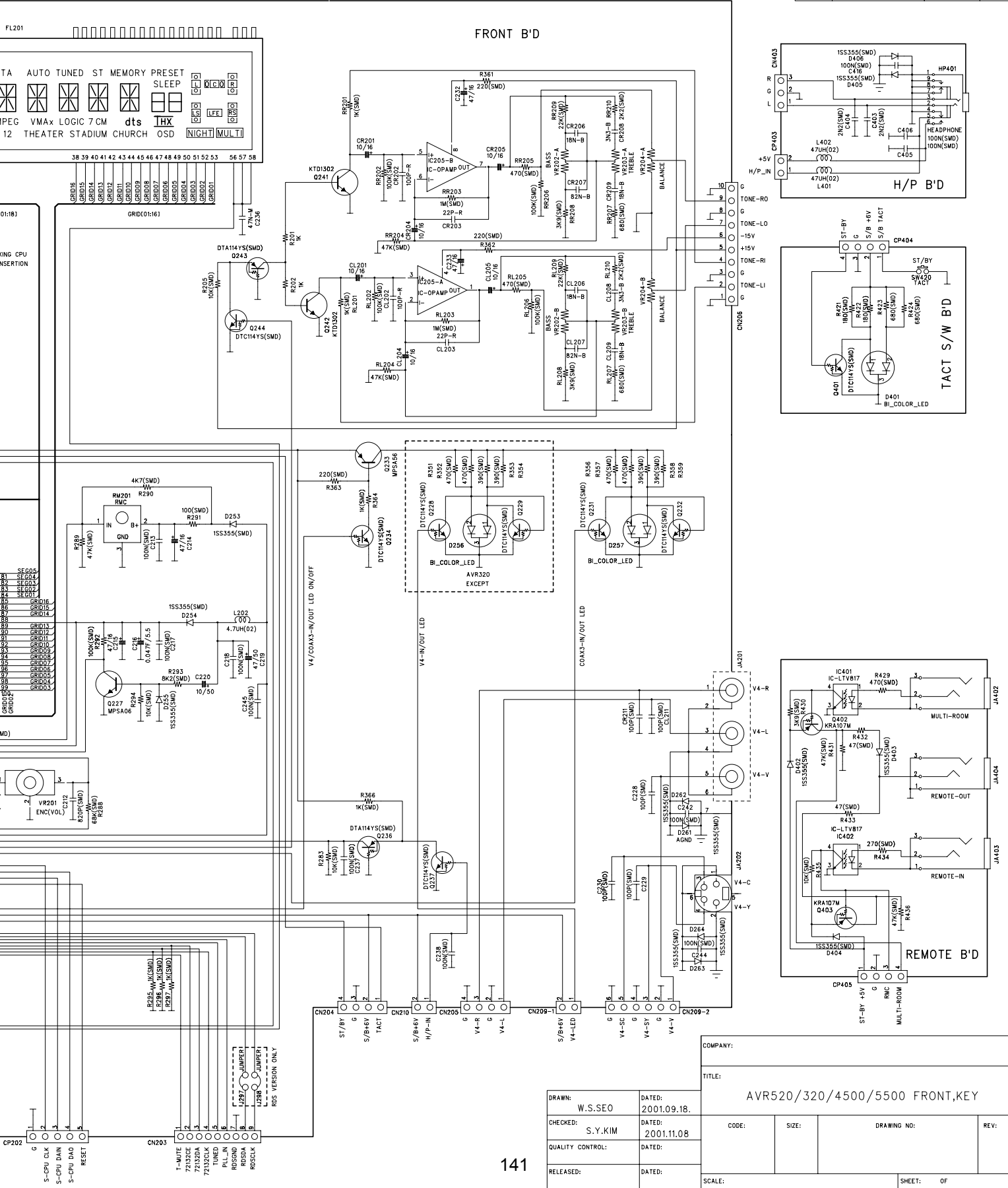

DRAWN: W.S.SEO		DATED: 2001.09.18.	
CHECKED: S.Y.KIM		DATED: 2001.11.08	
QUALITY CONTROL:		DATE:	
RELEASED:		DATED:	
COMPANY: harman/kardon			
TITLE: AVR520/320/4500/5500 FRONT,KEY			
CODE:	SIZE:	DRAWING NO:	REV:
SCALE:	SHEET: OF		

AVR320

harman/kardon

REVISION RECORD			
LTR	ECO NO.	APPROVEE	DATE

SCHEMATIC DIAGRAM INPUT B'D

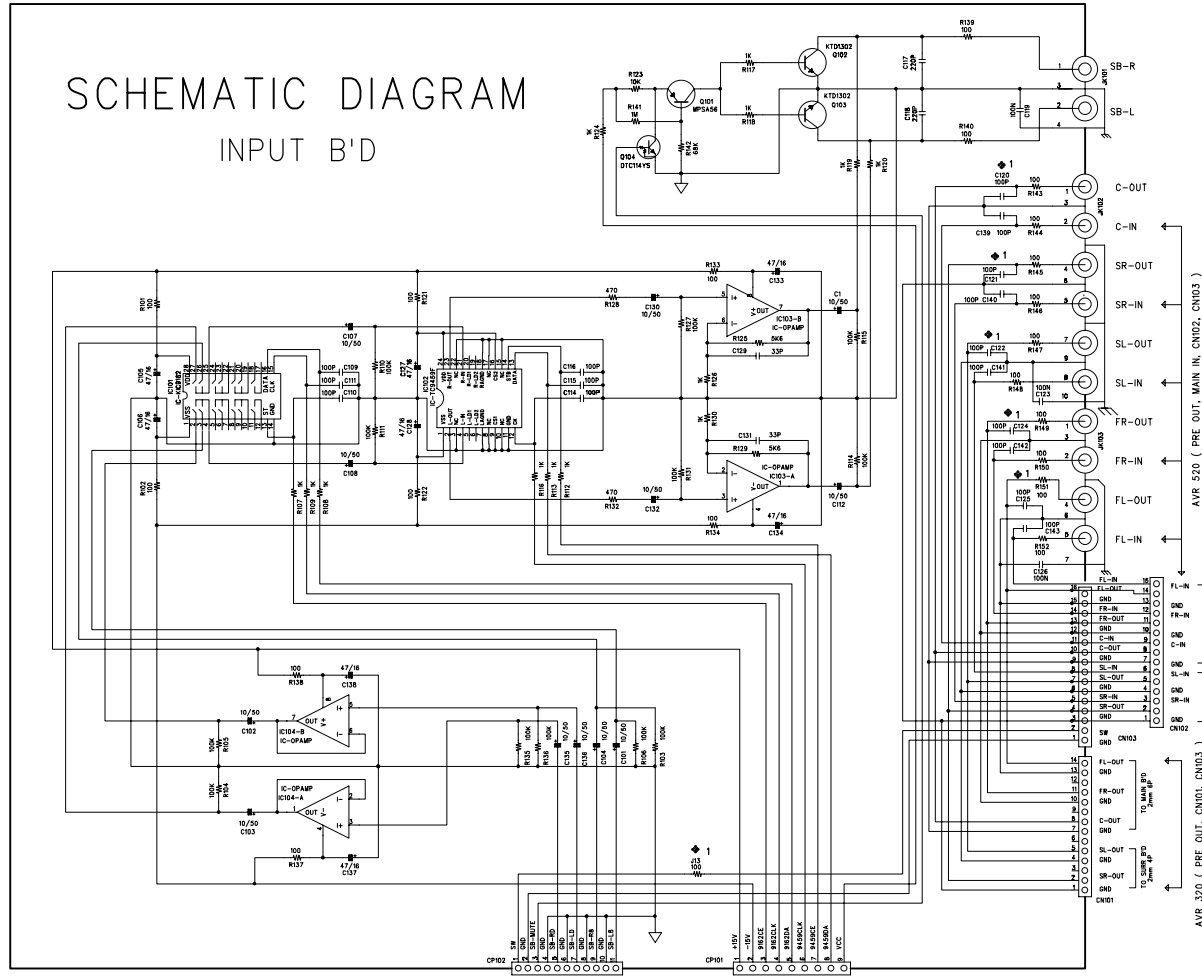

◆ 1 OPTION

MODEL	AVR320	AVR520	AVR4500	AVR5500
R143,R145,R147	JUMPER	JUMPER	1000hm	1000hm
R149,R151	JUMPER	JUMPER	1000hm	JUMPER
R144,R146,R148	X	JUMPER	X	JUMPER
R150,R152	X	X	100P	100P
C120,C121,C122	X	X	X	X
C124,C125	X	X	X	X
C138,C140,C141	X	X	X	X
C142,C143	X	X	X	X

COMPANY: **harman/kardon**

TITLE: **AVR520/320/4500/5500 INPUT**

DRAWN: W.S.SEO	DATE: 2001.09.18.	CODE:	SIZE:	DRAWING NO.:	REV:
CHECKER: S.Y.KIM	DATE: 2002.01.04	SCALE:	SHEET: OF		
QUALITY CONTROL:	DATE:				
RELEASED:	DATE:				

SCHEMATIC DIAGRAM

INPUT B'D

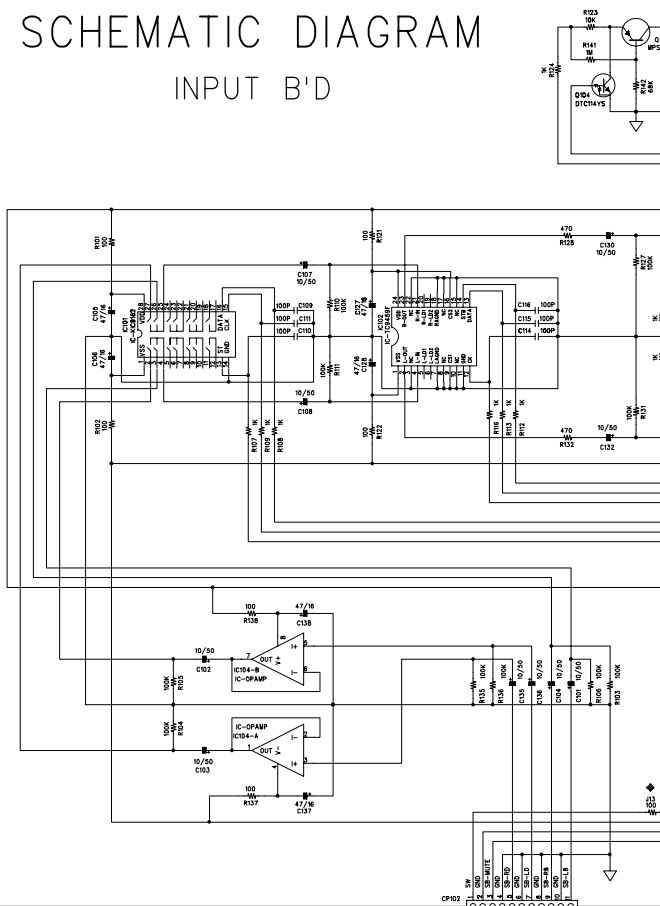

AVR320

harman/kardon

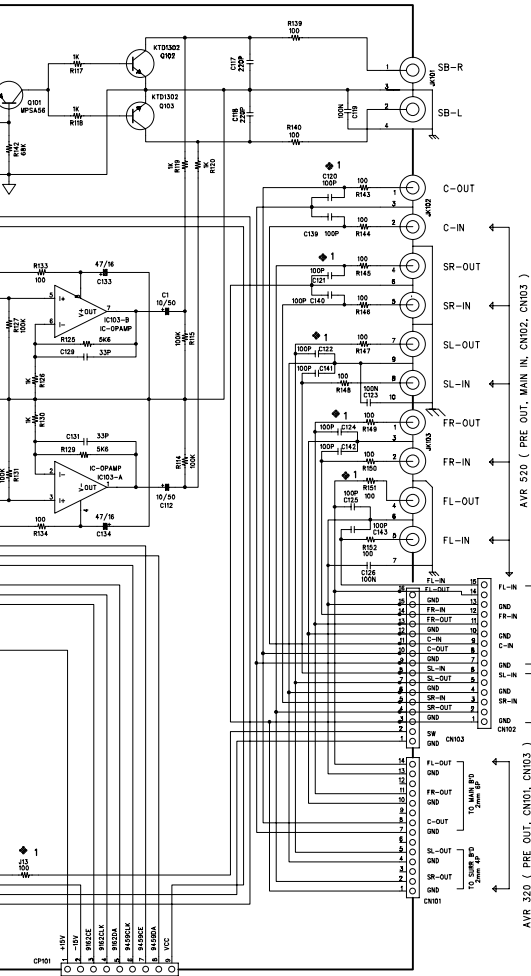

◆ 1 OPTION

MODEL	AVR320	AVR520	AVR4500	AVR5500
J3	JUMPER	JUMPER	1000nm	1000nm
R143,R145,R147	JUMPER	JUMPER	1000nm	JUMPER
R149,R151	JUMPER	JUMPER	1000nm	JUMPER
R144,R146,R148	X	JUMPER	X	JUMPER
R250,R152	X	X	100P	100P
C120,C121,C122	X	X	100P	100P
C124,C125	X	X	X	X
C139,C140,C141	X	X	X	100P
C142,C143	X	X	X	X

AVR 520 (PRE OUT, MAIN IN, CN102, CN103)

AVR 320 (PRE OUT, CN101, CN103)

COMPANY:			
TITLE:			
AVR520/320/4500/5500 INPUT			
CODE:	SIZE:	DRAWING NO:	REV:
SCALE:		SHEET: OF	

DRAWN:	W.S.SEO	DATED:	2001.09.18.
CHECKED:	S.Y.KIM	DATED:	2002.01.04
QUALITY CONTROL:		DATED:	
RELEASED:		DATED:	

D

C

B

A

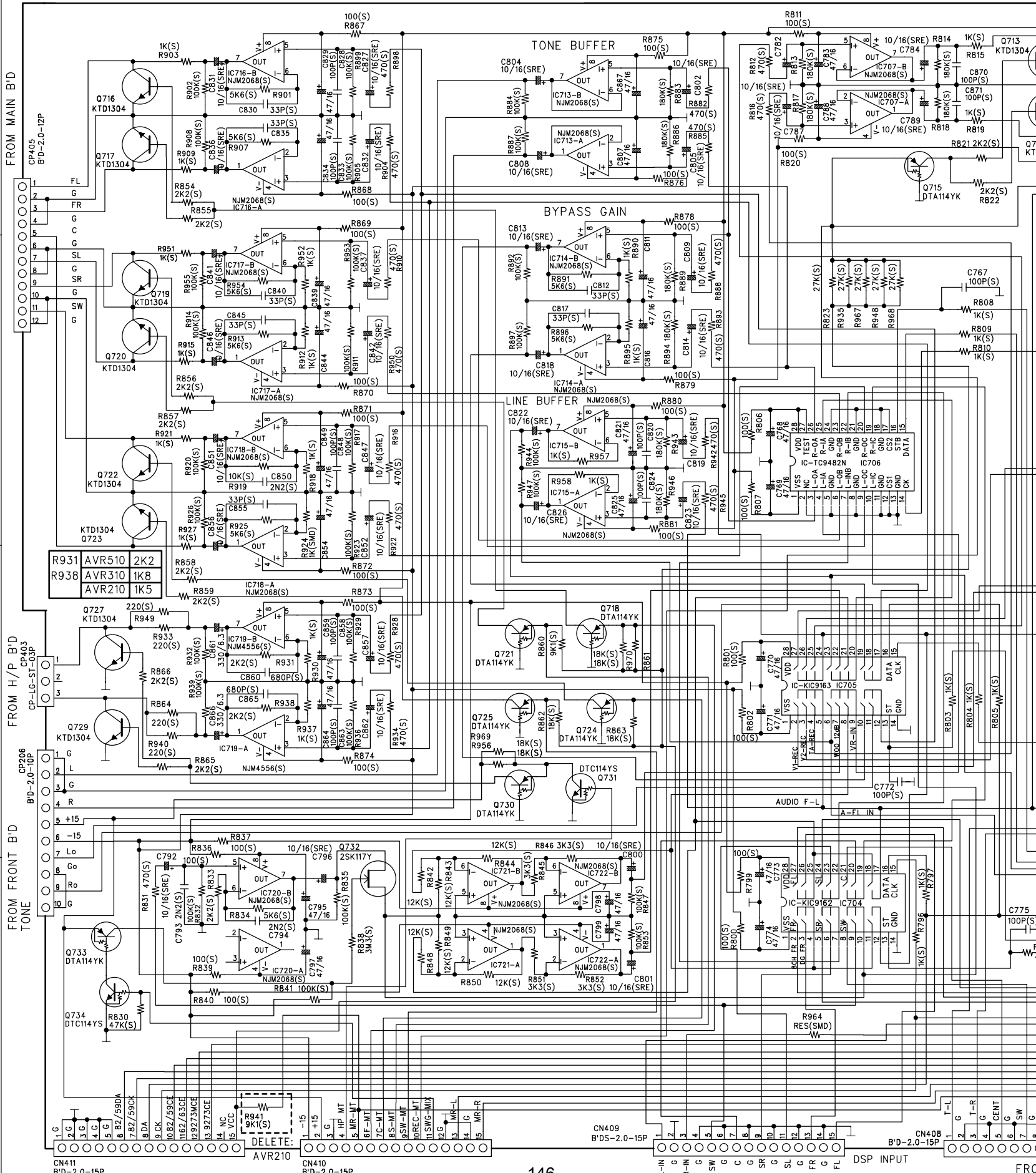

AGRAM

FROM TAPE B'D
CP404
CP-LG-ST-07P

VID4 I/O
FROM FRONT B'D
CP205
CP-LG-ST-04P

MP

REVISION RECORD

LTR	ECO NO:	APPROVED:	DATE:

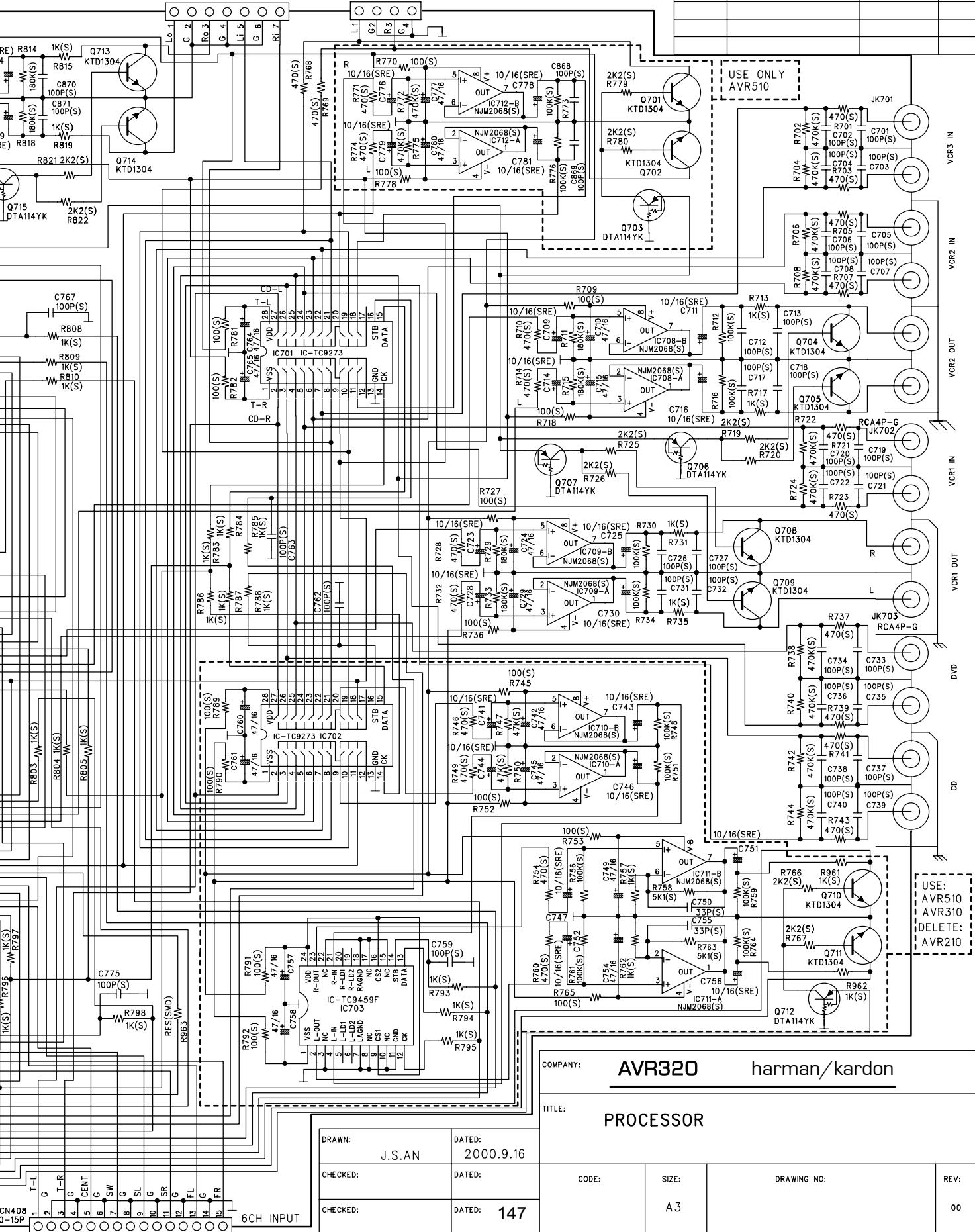

COMPANY: **AVR320** harman/kardon

TITLE: **PROCESSOR**

DRAWN:	DATED:
J.S.AN	2000.9.16
CHECKED:	DATED:
CHECKED:	DATED:
	147
RELEASED:	DATED:
K.S.SHIM	

CODE:	SIZE:	DRAWING NO:	REV:
	A3		00
SCALE:	SHEET: OF		

FROM MAIN B'D

6CH INPUT

- T-L
- G
- T-R
- C
- CENT
- G
- SW
- SL
- G
- SR
- FL
- FR

D
C
B
A

REVISION RECORD			
LTN	ECO NO.	APPROVED	DATE

D

C

B

A

D

C

B

A

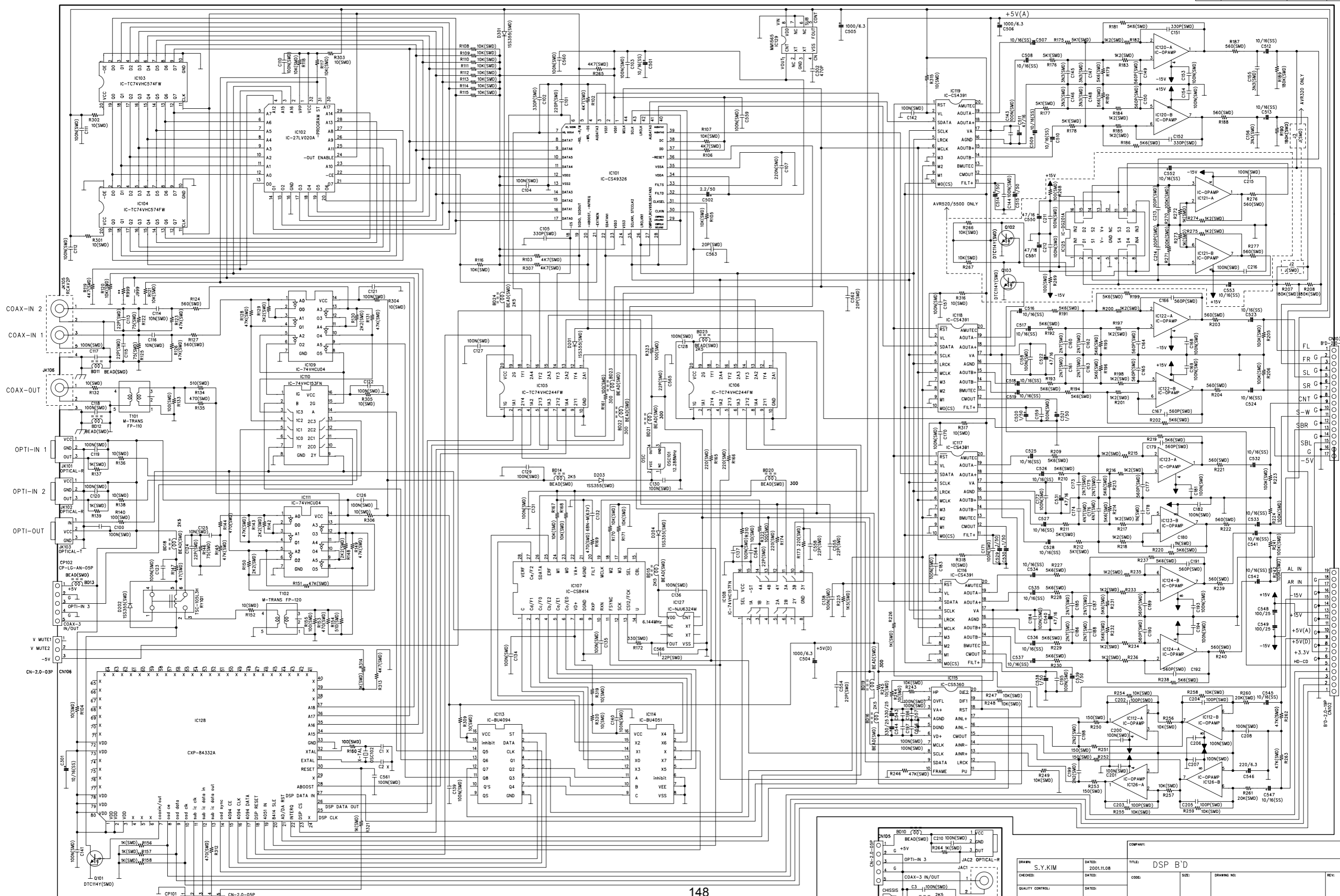

DRAWN	S.Y.KIM	DATE:	2001.11.08	TITLE:	DSP B'D
CHECKED:		DATE:		CODE:	
QUALITY CONTROL:		DATE:		SIZE:	
RELEASED:		DATE:		DRAWING NO.:	
				SHEET:	OF

D

C

B

A

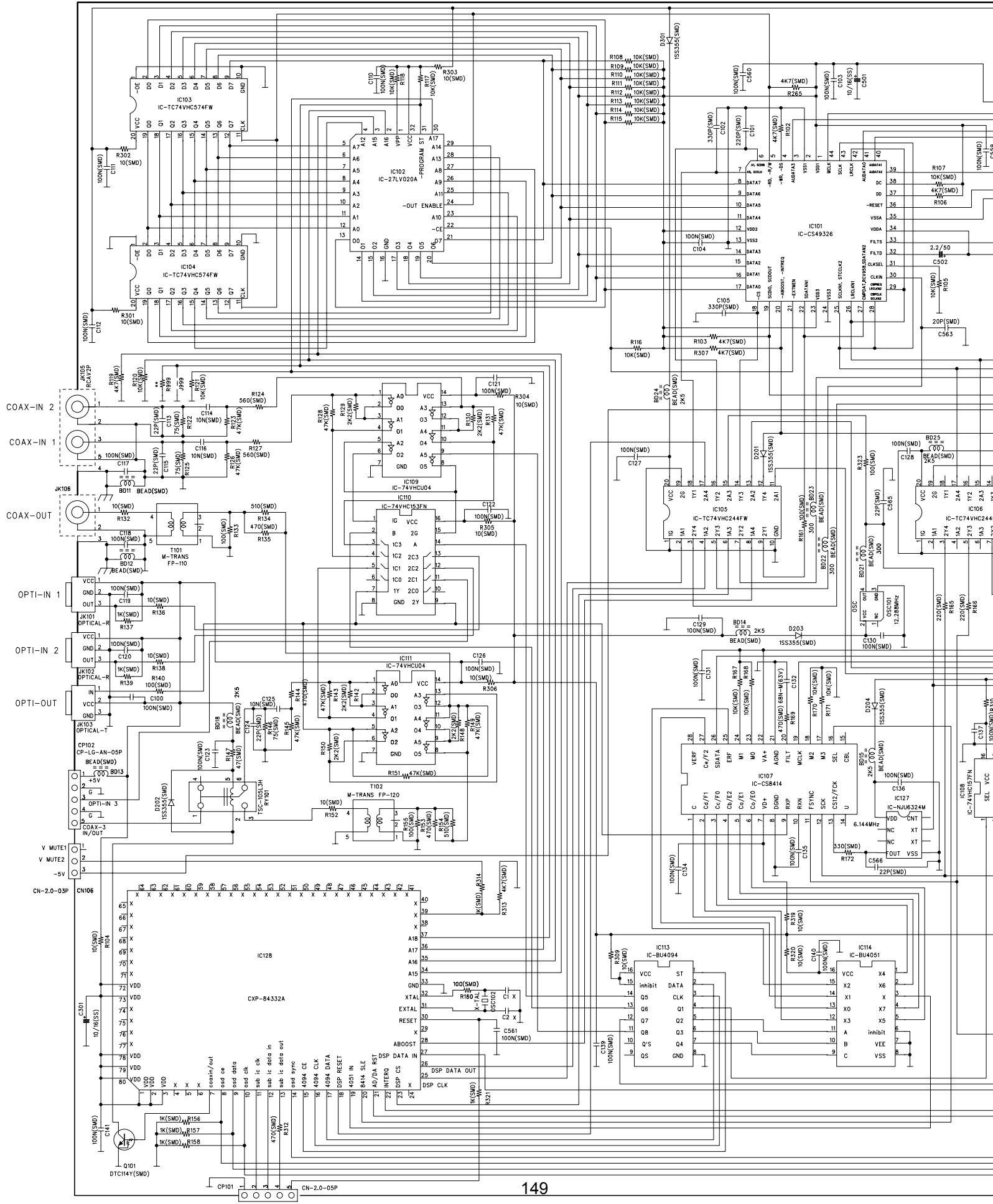

RAM AVR320/520/4500/5500 DSP B'D

REVISION RECORD			
LTR	ECO NO:	APPROVED:	DATE:

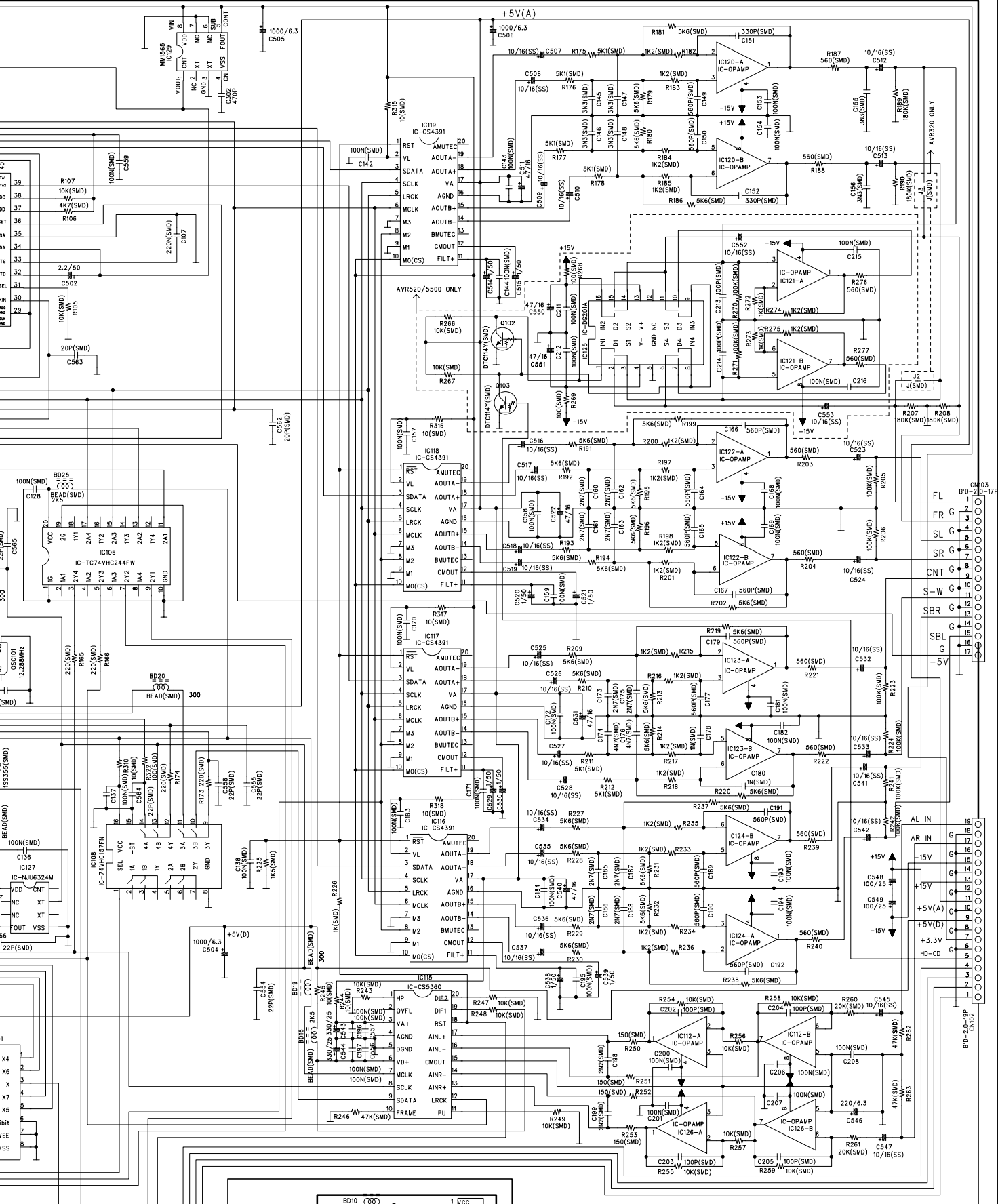

D

C

B

A

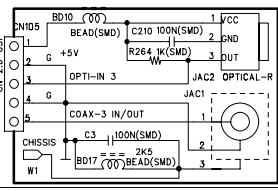

150

DRAWN: S.Y.KIM		DATED: 2001.11.08		TITLE: DSP B'D	
CHECKED:	DATE:	CODE:	SIZE:	DRAWING NO:	REV:
QUALITY CONTROL:	DATE:	SCALE:	SHEET: OF	AGND	
RELEASED:	DATE:				

REAR AMP ASS'Y

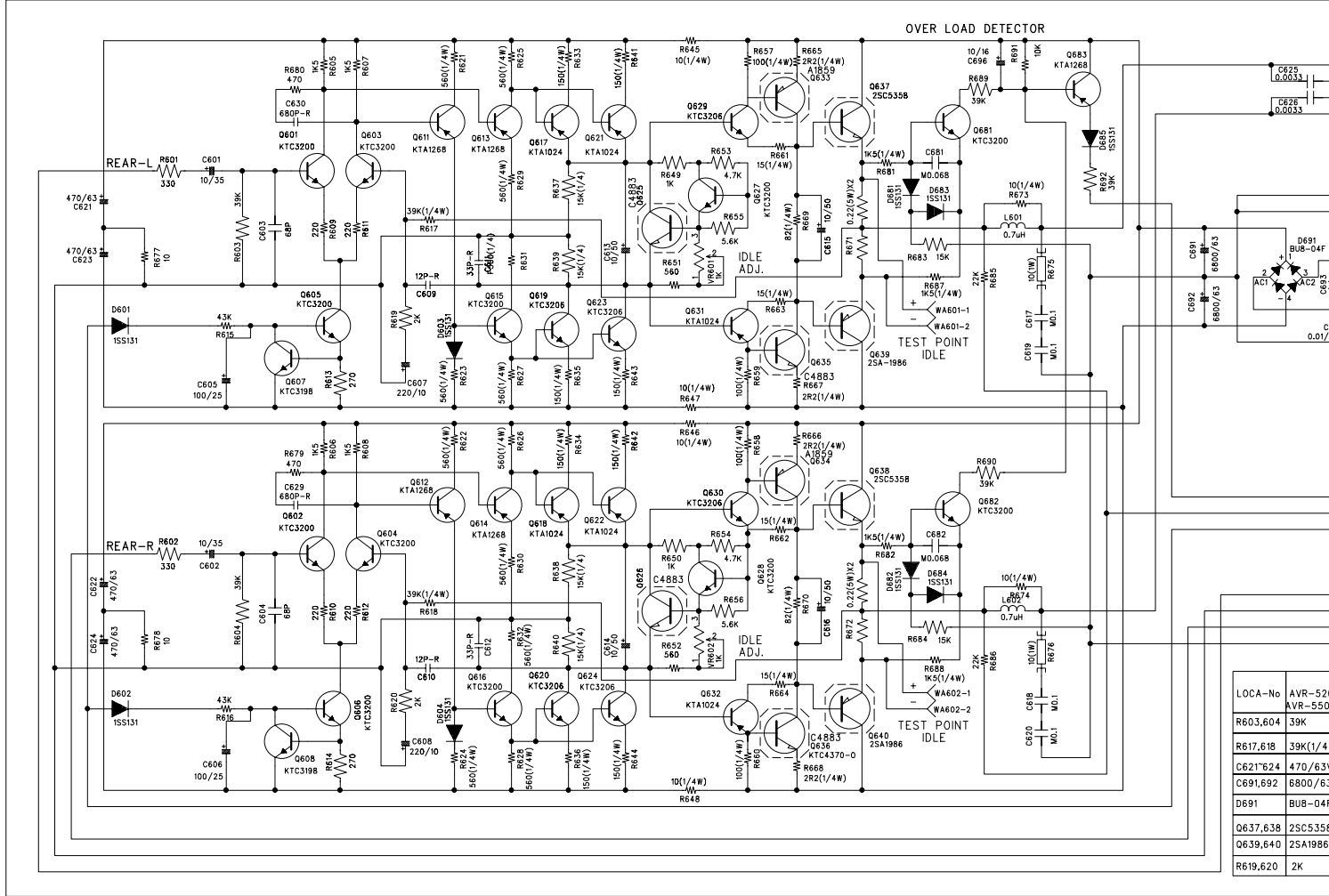

LOC#-No	AVR-52
	AVR-550
R603,604	39K
R617,618	39K(1/4
C621,624	470/63
C691,692	6800/63
D691	BUB-04F
Q637,638	2SC5358
Q639,640	2SA1986
R619,620	2K

SUB POWER SUPPLY ASS'Y

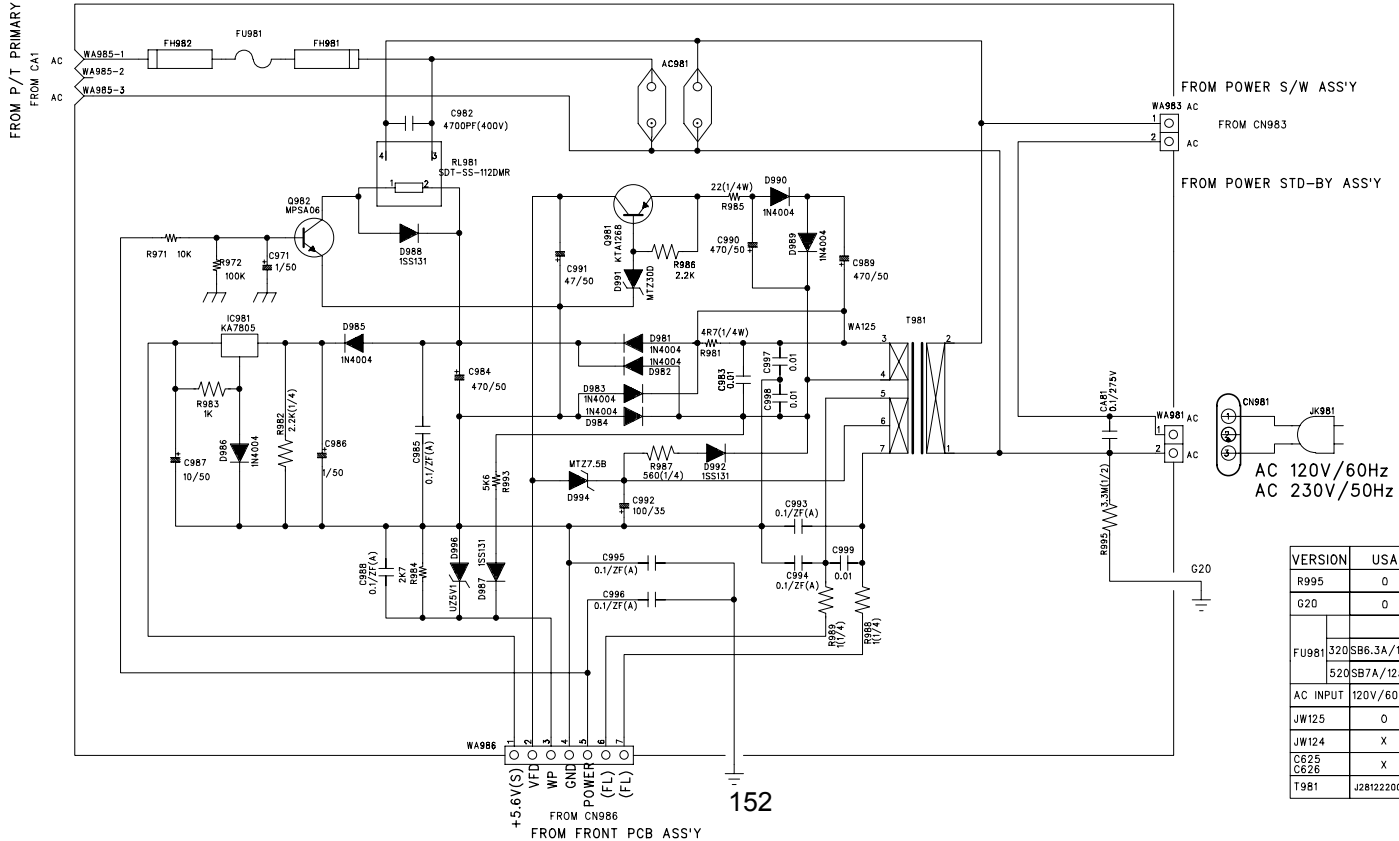

VERSION	USA	EU
R995	0	X
G20	0	X
FU981	320SB6.3A/125V	T4A/250V
	520SB7A/125V	T5A/250V
AC INPUT	120V/60Hz	230V/50Hz
JW125	0	X
JW124	X	0
C625	X	0
C626	X	0
T981	J2812220012X	J2812420032X

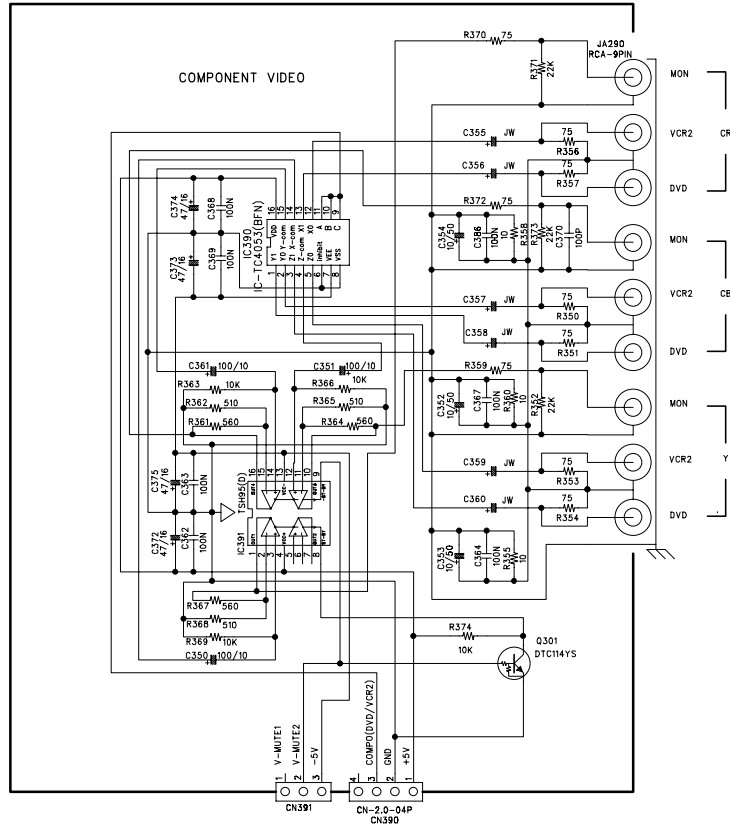
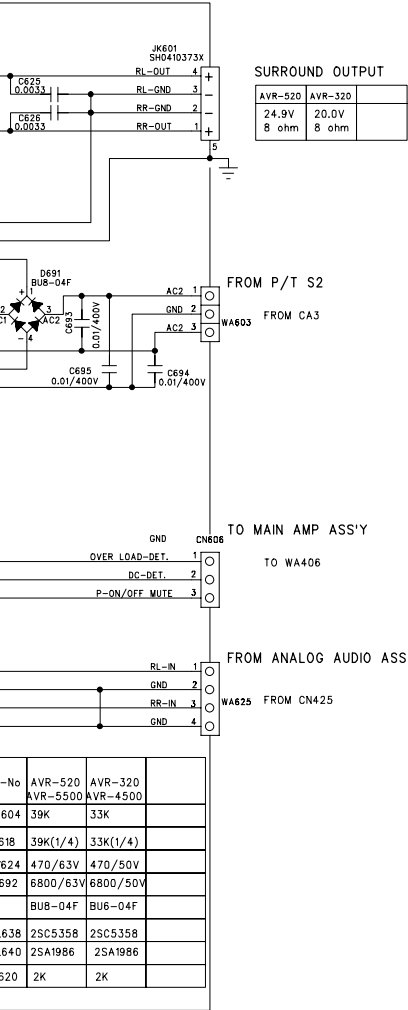

CONFIDENTIAL/CONTROL COPY

FILENAME SURROUND	CODE NO.	SHEET 1 / 1		
MODEL AVR320/520	DESIGN	CHKD	CHKD	APPROVAL
DESIGN DATE 01.11.08	S.Y.KIM			

AVR 520	AVR 320
25V	22V
8 ohm	8 ohm
80W+2	60W+2
70W+5	50W+5

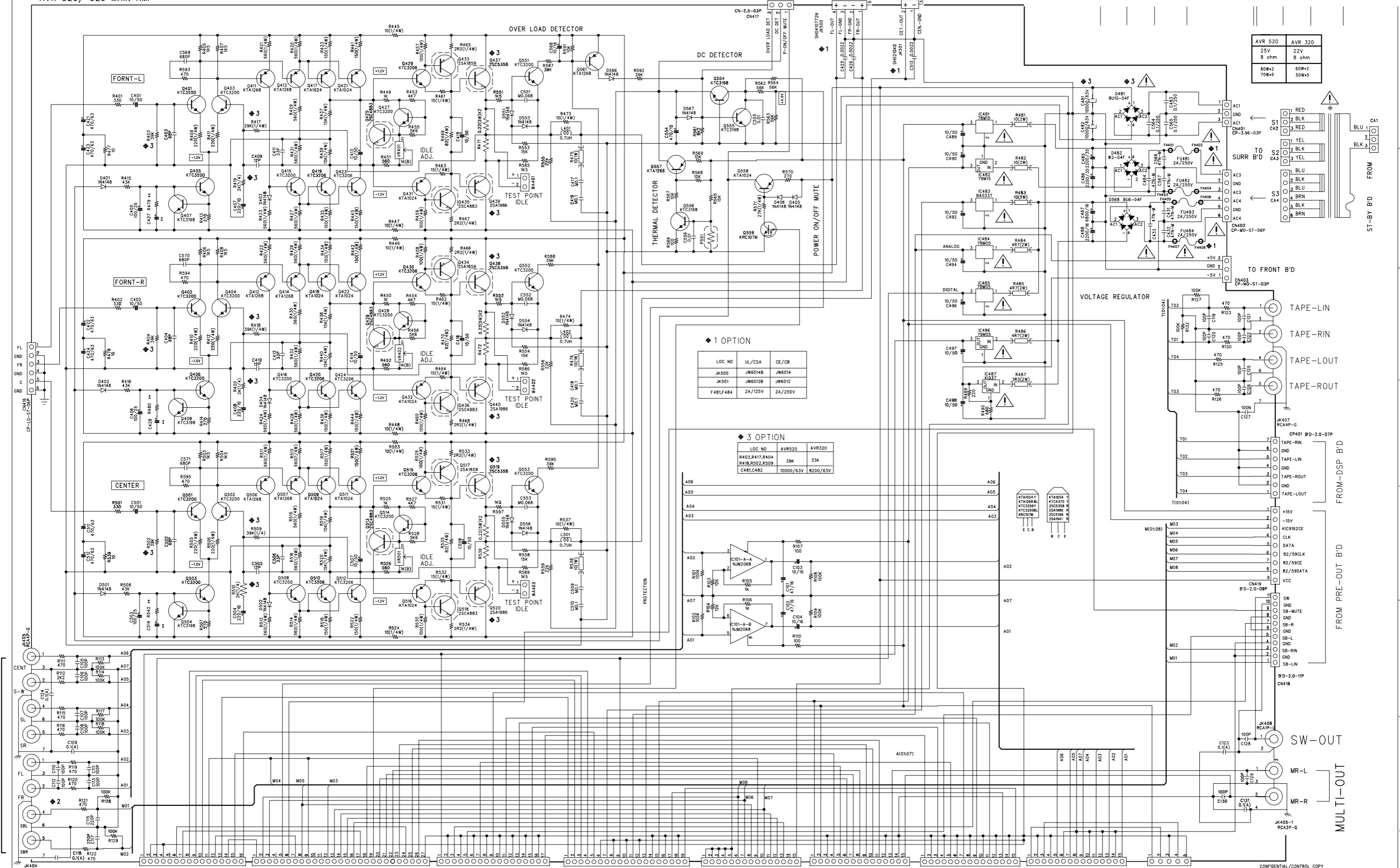

◆ 1 OPTION

LOC NO	UL/CSA	CE/CB
JK500	JWE014B	JWE014
JK501	JWE012B	JWE012
F481,F484	2A/125V	2A/250V

◆ 3 OPTION

LOC NO	AVR520	AVR320
R403,R417,R404	39K	33K
R418,R502,R509		
C481,C482	10000/63V	8200/63V

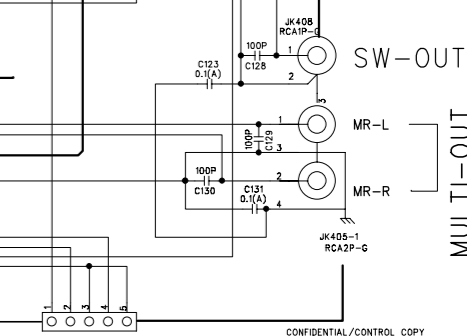
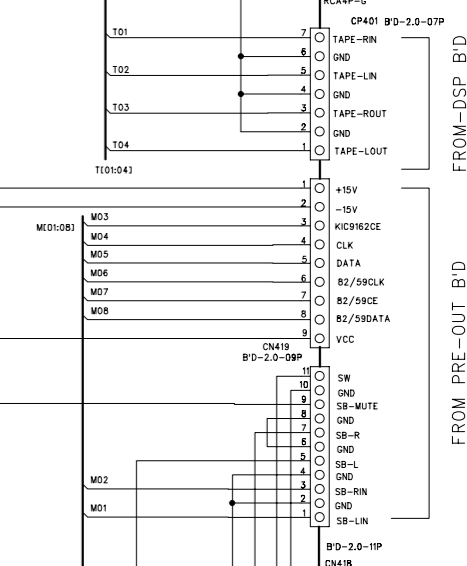
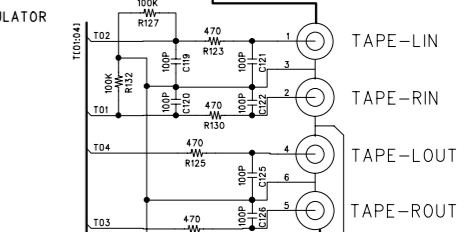
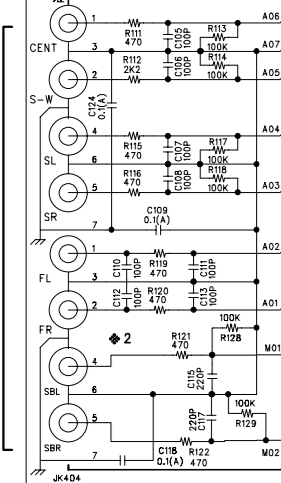

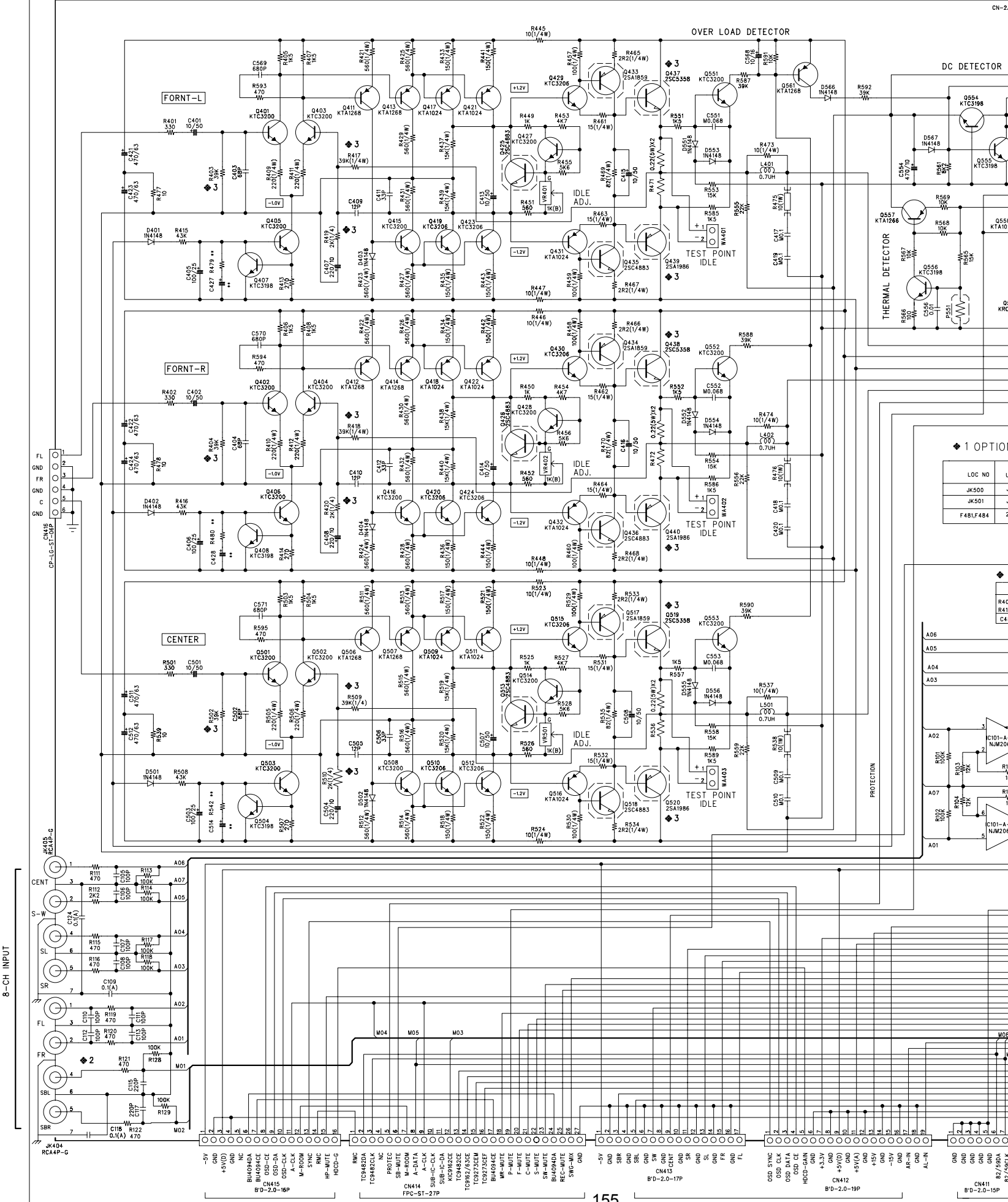

◆ 1 OPTION

LOC NO	UL/
JK500	JW6
JK501	JW6
F481,484	2A/

◆ 3

LOC	UL/
R403, R418, R419	1K
C481, C482	100K

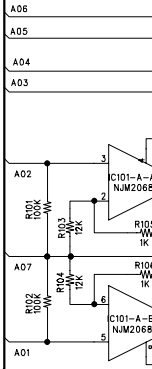

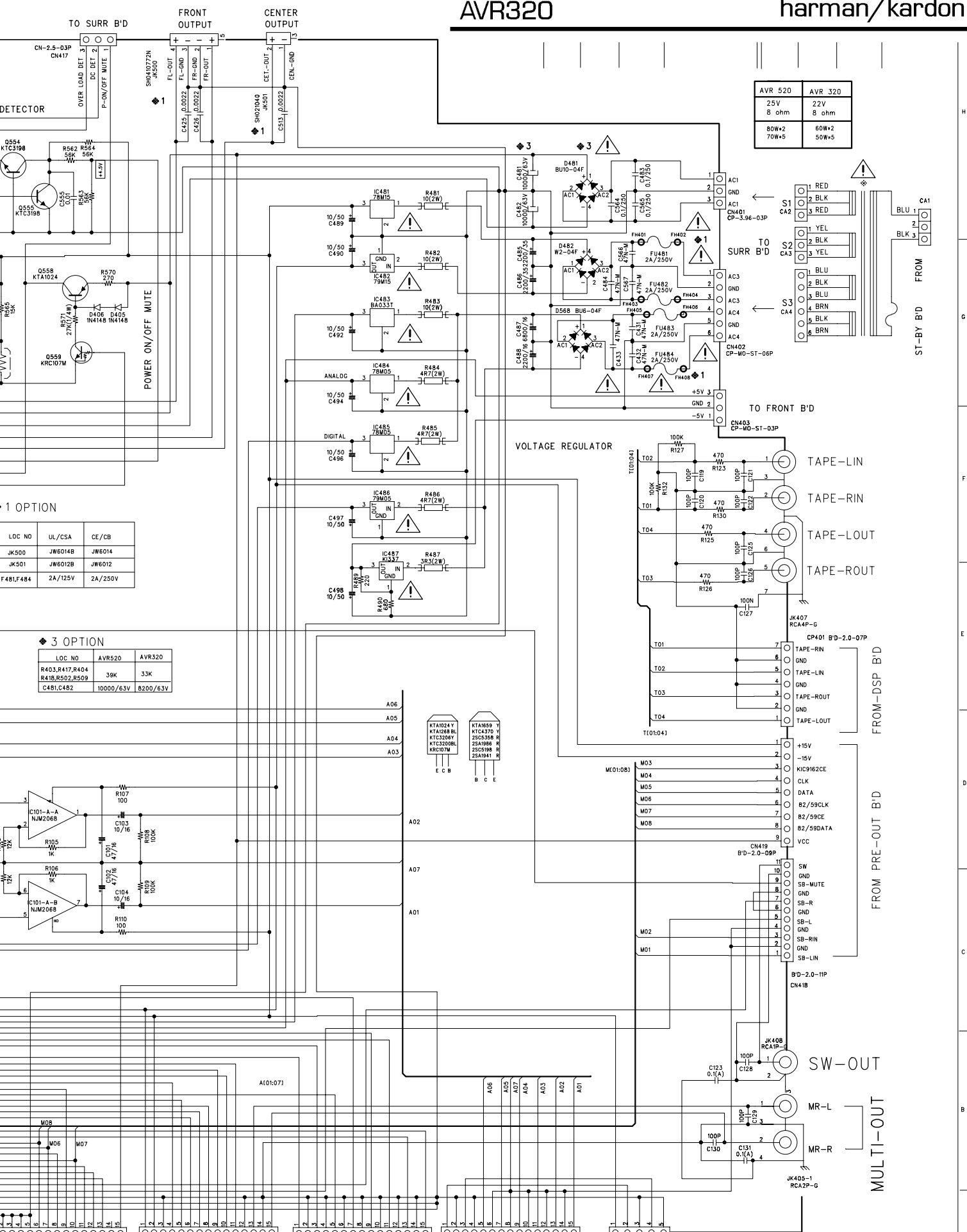

AVR 520	AVR 320
25V 8 ohm	22V 8 ohm
80W+2 70W+5	60W+2 50W+5

1 OPTION

LOC NO	UL/CSA	CE/CB
JK500	JW6014B	JW6014
JK501	JW6012B	JW6012
F481,F484	2A/125V	2A/250V

3 OPTION

LOC NO	AVR520	AVR320
R403,R417,R404	39K	33K
C481,C482	10000/63V	8200/63V

CONFIDENTIAL/CONTROL COPY

FILENAME	CODE NO.	SHEET
MODEL AVR-520/320	DESIGN S.Y.KIM	CHKD
DESIGN DATE 2001.11.08	CHKD	APPROVAL

WIRING DIAGRAM

AVR320

harman/kardon

REVISION RECORD			
LTR	ECC NO.	APPROVED	DATE

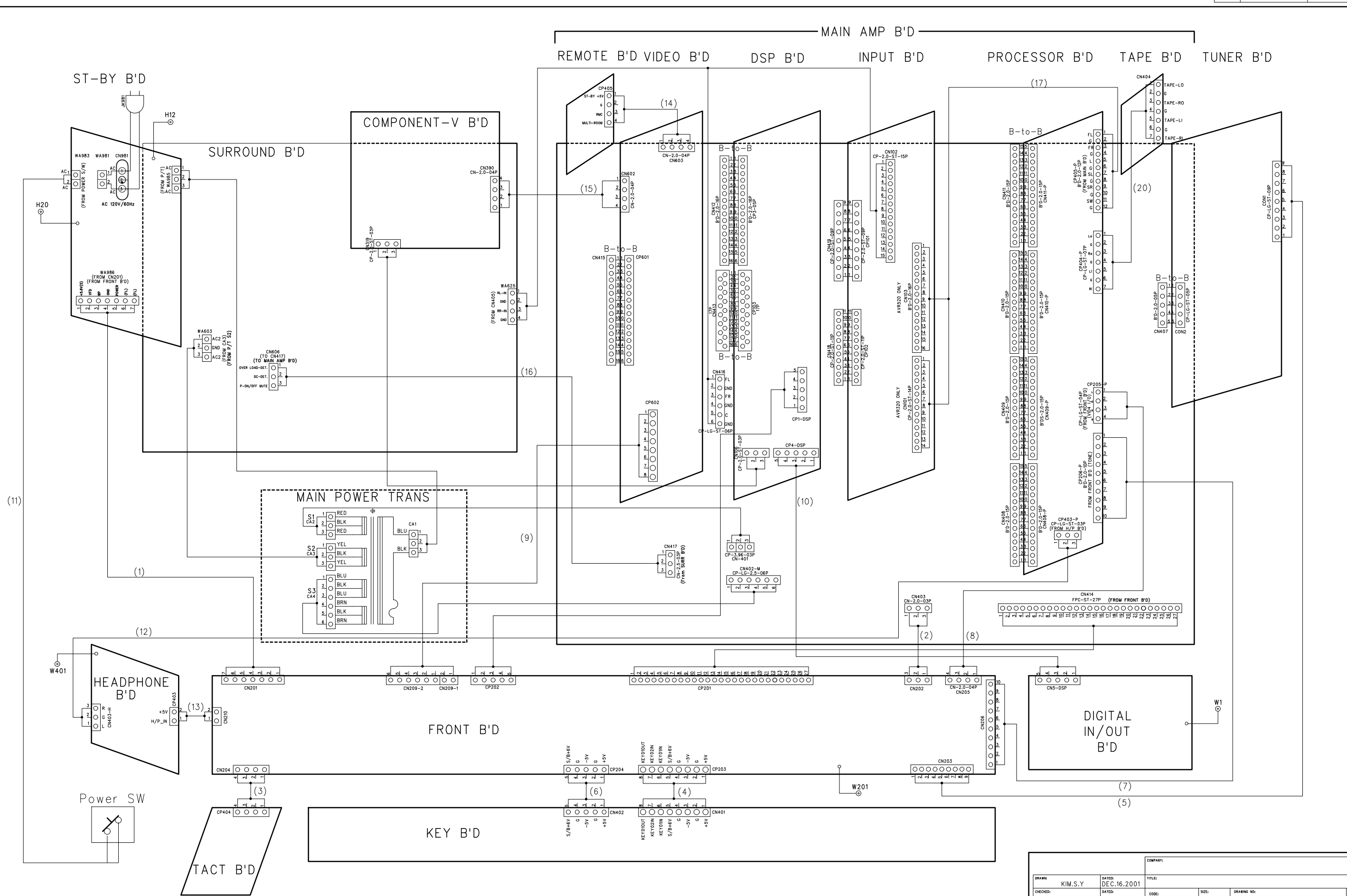

DRAWN		DATED		TITLE	
	KIM.S.Y		DEC.16.2001		
CHECKED		DATED		CODE	
QUALITY CONTROL		DATED		SCALE	
RELEASED		DATED		SCALE	

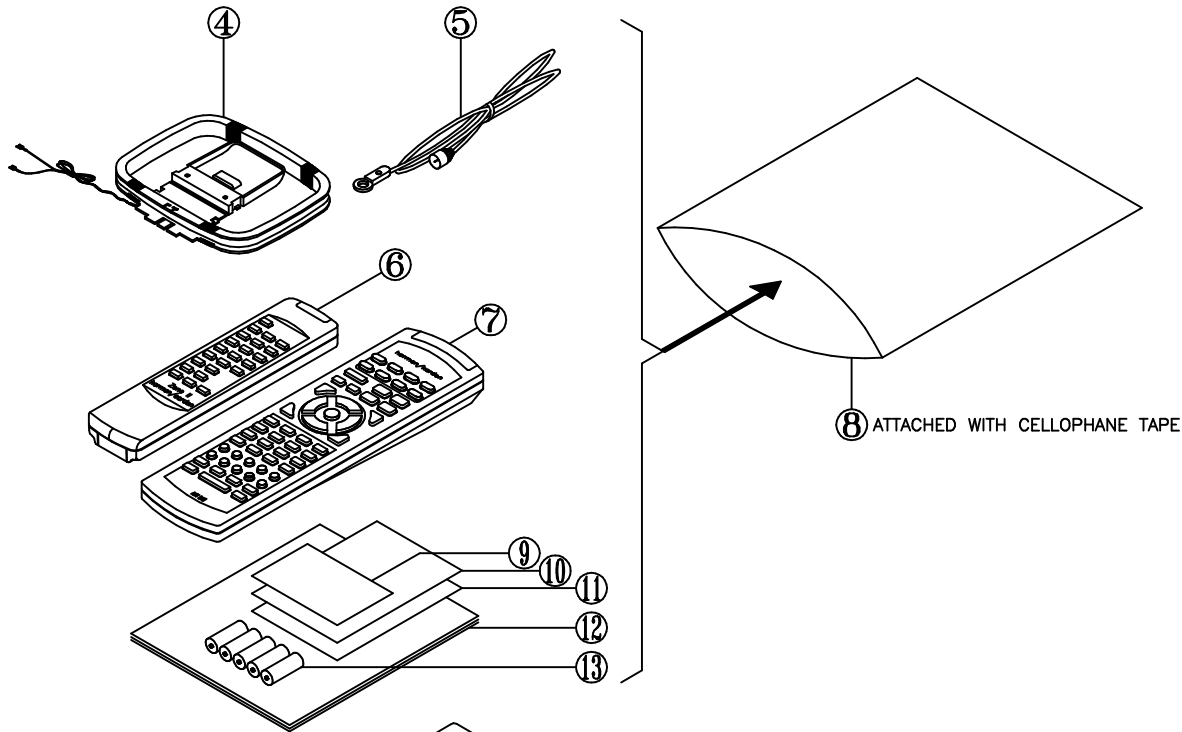

NO.	PARTS NO.	DESCRIPTION	AVR							
			520US	320US	220US	120US	5500EU	4500EU	3500EU	2500EU
1	55178610XX	CUSHION POLY	2	2	2	2	2	2	2	2
	55178880XX	BOX CARTON AVR 520 US	1							
	55198680XX	BOX CARTON AVR 320 US		1						
	55244340XX	BOX CARTON AVR 220 US			1					
	55244330XX	BOX CARTON AVR 120 US				1				
2	55247310XX	BOX CARTON AVR 5500 EU					1			
	55247300XX	BOX CARTON AVR 4500 EU						1		
	55243020XX	BOX CARTON AVR 3500 EU							1	
	55243010XX	BOX CARTON AVR 2500 EU								1
3	55170680XX	SHEET PE 0.5t	1	1	1	1	1	1	1	1
4	55127490XX	AM ANTENNA LOOP	1	1	1	1	1	1	1	1
	55127460XX	FM ANTENNA 75 US						1	1	1
5	55127450XX	FM ANTENNA 75 US	1	1	1	1				
6	55178550XX	ASSY REMOCON ZONE II	1	1	1			1	1	
	55178540XX	ASSY REMOCON AVR 520 US	1							
	55194410XX	ASSY REMOCON AVR 320 US		1						
	55244360XX	ASSY REMOCON AVR 220 US			1					
	55244350XX	ASSY REMOCON AVR 120 US				1				
7	55262330XX	ASSY REMOCON AVR 5500 EU					1			
	55262320XX	ASSY REMOCON AVR 4500 EU						1		
	55242990XX	ASSY REMOCON AVR 3500 EU							1	
	55242980XX	ASSY REMOCON AVR 2500 EU								1
8	55164890XX	POLY BAG PE 0.05t	1	1	1	1	1	1	1	1
9	55178720XX	CARD POST PAPER	1	1	1	1				
10	55178740XX	CADR WARRANTY PAPER	1	1	1	1	1	1	1	1
11	55178770XX	SAFETY LEAFLET PAPER	1	1	1	1	1	1	1	1
	55180380XX	MANUAL AVR 520 US	1							
	55198690XX	MANUAL AVR 320 US		1						
	55244450XX	MANUAL AVR 220 US			1					
	55244440XX	MANUAL AVR 120 US				1				
12	55247330XX	MANUAL AVR 5500 EU					1			
	55247320XX	MANUAL AVR 4500 EU						1		
	55243040XX	MANUAL AVR 3500 EU							1	
	55243030XX	MANUAL AVR 2500 EU								1
13	55020220NR	BATTERY 1.5V AAA	3	3	5	5	3	3	5	5
	55178380XX	LABEL BARCODE AVR 520 US	2							
	55198670XX	LABEL BARCODE AVR 320 US		2						
	55244410XX	LABEL BARCODE AVR 220 US			2					
	55244380XX	LABEL BARCODE AVR 120 US				2				
	55247290XX	LABEL BARCODE 5500 EU					2			
	55247280XX	LABEL BARCODE 4500 EU						2		
	55242960XX	LABEL BARCODE 3500 EU							2	
	55242950XX	LABEL BARCODE 2500 EU								2

AVR320

harman/kardon

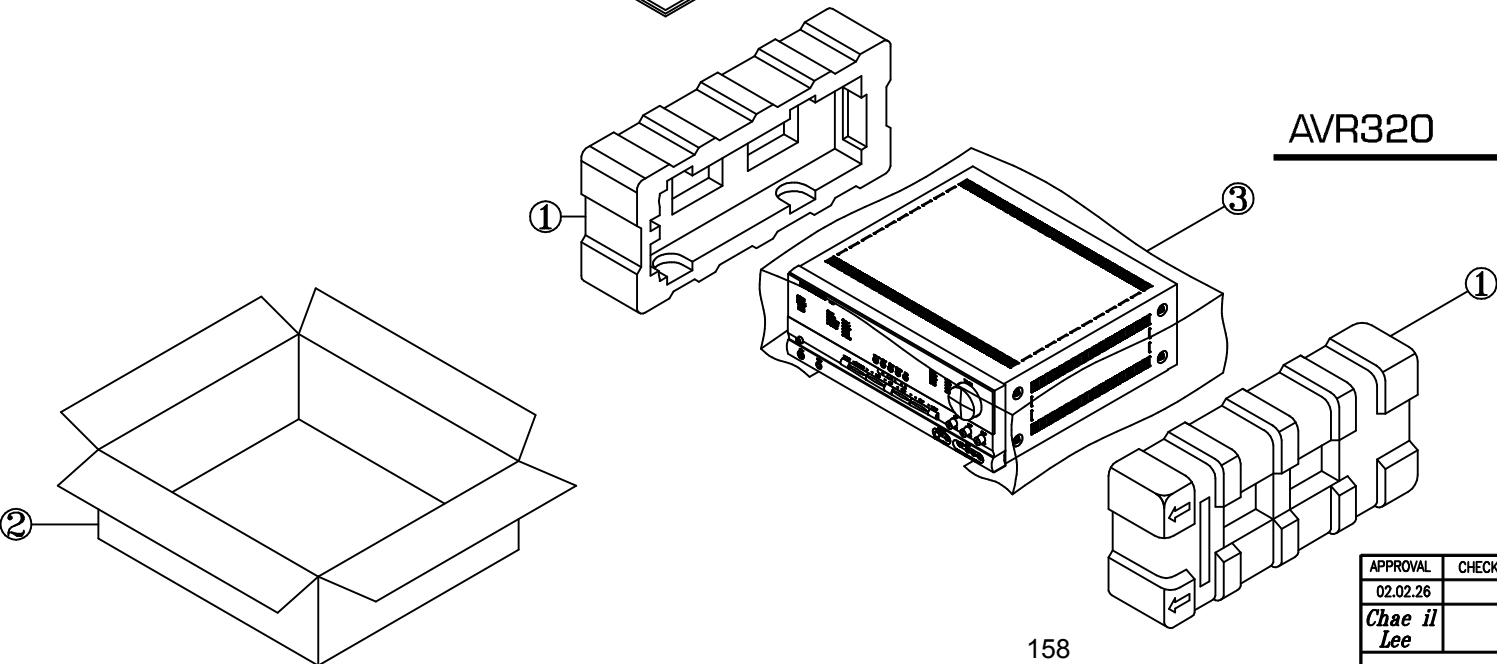

APPROVAL	CHECK	DRAWING	DESIGN	MODEL	SCALE	TOLERANCE	PARTS NAME
02.02.26		02.02.26					PACKING DRAWING
<i>Chae il Lee</i>		<i>Dong il Choi</i>		N/S		LESS; ±	MODEL NO. AVR 520/320/220/120 US
				UNIT		LESS; ±	AVR5500/4500/3500/2500 EU
				m/m		LESS;	